

INDEX

MANUFACTURER, MODEL APPLICATION GUIDE				1-113
Manufacturer	Page No.	Manufacturer	Page No.	
Acura	1	Jaguar	85	
Alfa-Romeo	1	Jeep	85-89	
American Motors	1-3	Kia	89	
Buick	3-4	Landrover	90	
Cadillac	4-5	Lexus	90	
Chevrolet	5-24	Lincoln	90-92	
Chrysler	24-25	Mazda	92-95	
Dodge	25-36	Mercury	96-99	
Fiat	36-37	Mitsubishi	99-101	
Ford	37-65	Nissan-Datsun	101-104	
Geo	65	Oldsmobile	104-106	
GMC	66-82	Plymouth	106-108	
Honda	82	Pontiac	108-110	
Hummer	82-83	Suzuki	110-111	
Isuzu	83-85	Toyota	111-113	

CONVERSION KIT LISTING BY PART NUMBER	114-116
--	----------------

OE SERIES CHARTS	117-118
-------------------------	----------------

HARDWARE - UBOLTS, BEARING CLAMPS, LOCK STRAPS & CAP SCREWS	117-118
--	----------------

IDENTIFICATION SECTIONS		120-130
4 OSR STYLE KITS	120-121	
4 ISR STYLE KITS	122-123	
2 ISR & 2OSR STYLE KITS	124-125	
4 BACKPLATE STYLE KITS	126	
2 OSR & 2 BACKPLATE STYLE KITS	126	
4 BLOCK OR WING STYLE KITS	127-128	
2 OSR & 2 BLOCK OR WING STYLE KITS	129	
2 BACKPLATE & 2 BLOCK OR WING STYLE KITS	130	
2 ISR & 2 BLOCK OR WING STYLE KITS	130	

BUYERS GUIDE by Part No.	131-140
---------------------------------	----------------

1000 SERIES PTO YOKES		141-150
QUICK REFERENCE GUIDE BY PART NUMBER	141	
QUICK REFERENCE GUIDE BY BORE DIAMETER	142	
1000 SERIES PTO END YOKES	143-148	
1000 SERIES PTO SLIP YOKES	149-150	

DRIVESHAFT CENTER SUPPORTS		151-163
DOMESTIC APPLICATION LISTING	151-156	
IMPORT APPLICATION LISTING	157	
ILLUSTRATION GUIDE	158-161	
IDENTIFICATION LISTING	162-163	

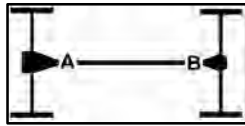

APPLICATION A-1

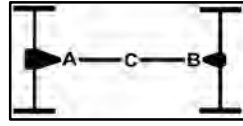

APPLICATION B-1

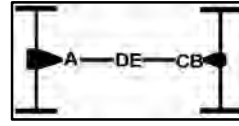

APPLICATION C-1

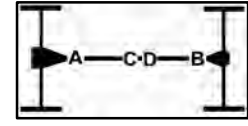

APPLICATION D-1

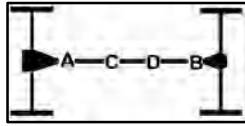

APPLICATION E-1

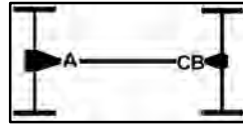

APPLICATION F-1

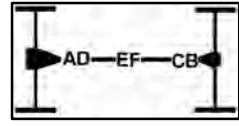

APPLICATION H-1

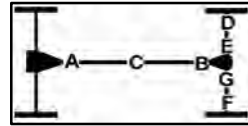

APPLICATION I-1

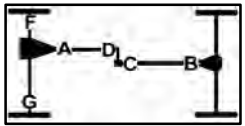

APPLICATION K-1

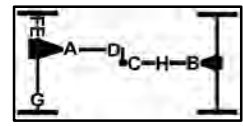

APPLICATION L-1

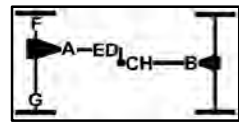

APPLICATION N-1



APPLICATION O-1

MAKE/YEARS FITMENT U-JOINT DESCRIPTION LOCATION POSITION PART NO.

ACURA		ACURA				
SLX						
98-99	All Models	4 ISR >1.142" Brg O.D./2.089" Stack-up	L-1	A / D	PT1621	
		4 ISR >1.142" Brg O.D./2.835" Stack-up	L-1	B / C	PT411	
96-97	All Models	4 ISR >1.142" Brg O.D./2.089" Stack-up	L-1	A / B / C / D / H	PT1621	

ALFA-ROMEO		ALFA-ROMEO				
164						
91-95	All Models	4 OSR > .938" Brg O.D./2.407" Stack-up	A-1	A / B	PT514	
GTV						
81-86	All Models	4 OSR > .938" Brg O.D./2.407" Stack-up	A-1	A / B	PT514	
MILANO						
87-89	All Models	4 OSR > .938" Brg O.D./2.407" Stack-up	A-1	A / B	PT514	
SPIDER						
70-94	All Models	4 OSR > .938" Brg O.D./2.407" Stack-up	A-1	A / B	PT514	

AMERICAN MOTORS (AMC)		AMERICAN MOTORS (AMC)				
AMBASSADOR						
70-74	All Models	4 OSR > 1.063" Brg O.D/ 3.217" Stack-up	A-1	A / B	PT521HD	
AMX						
78-80	All Models	4 ISR > 1.078" Brg O.D./2.121" Stack-up	A-1	A / B	PT266	
		4 OSR > 1.063" Brg O.D/ 3.217" Stack-up	A-1	A / B	PT521HD	
		4 ISR >1.078"/1.125" Brg O.D./2.121"/2.362" Stack-up	A-1	B	PT353	
70-74	All Models	4 OSR > 1.063" Brg O.D/ 3.217" Stack-up	A-1	A / B	PT521HD	
CONCORD						
78-83	All Models	4 ISR > 1.078" Brg O.D./2.121" Stack-up	A-1	A / B	PT266	
		4 OSR > 1.063" Brg O.D/ 3.217" Stack-up	A-1	A / B	PT521HD	
		4 ISR >1.078"/1.125" Brg O.D./2.121"/2.362" Stack-up	A-1	B	PT353	
EAGLE						
82-88	All Models	4 OSR > 1.063" Brg O.D/ 3.217" Stack-up	K-1	A / B / C / D	PT521HD	

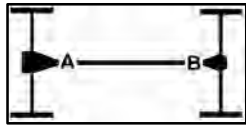

APPLICATION A-1

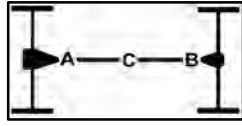

APPLICATION B-1

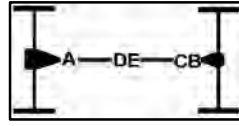

APPLICATION C-1

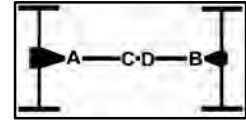

APPLICATION D-1

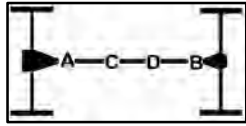

APPLICATION E-1

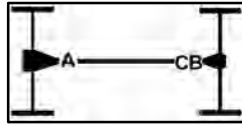

APPLICATION F-1

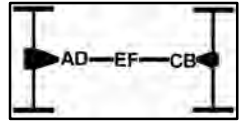

APPLICATION H-1

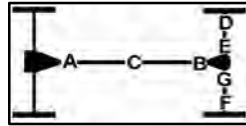

APPLICATION I-1

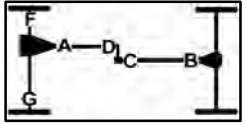

APPLICATION K-1

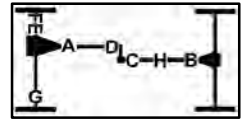

APPLICATION L-1

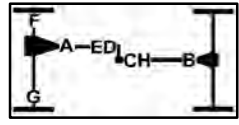

APPLICATION N-1



APPLICATION O-1

MAKE/YEARS FITMENT U-JOINT DESCRIPTION LOCATION POSITION PART NO.

AMERICAN MOTORS (AMC)

AMERICAN MOTORS (AMC)

EAGLE					
80-81 All Models	4 OSR > 1.063" Brg O.D/ 3.217" Stack-up		K-1	A / D / C	PT521HD
	4 ISR > 1.078" Brg O.D./2.121" Stack-up		K-1	C / B	PT266
	4 ISR > 1.078"/1.125" Brg O.D./2.121"/2.362" Stack-up		K-1	B	PT353
GREMLIN					
76-78 All Models	4 ISR > 1.078" Brg O.D./2.121" Stack-up		A-1	A / B	PT266
	4 OSR > 1.063" Brg O.D/ 3.217" Stack-up		A-1	A / B	PT521HD
1975 ALL V-8 MODELS	4 ISR > 1.078" Brg O.D./2.121" Stack-up		A-1	A / B	PT266
	4 OSR > 1.063" Brg O.D/ 3.217" Stack-up		A-1	A / B	PT521HD
ALL 6 CYL. MODELS	4 OSR > 1.063" Brg O.D/ 3.217" Stack-up		A-1	A / B	PT521HD
	4 OSR > 1.063" Brg O.D./2.437" Stack-up		A-1	A / B	PT315
70-74 All Models	4 OSR > 1.063" Brg O.D/ 3.217" Stack-up		A-1	A / B	PT521HD
HORNET					
76-77 All Models	4 ISR > 1.078" Brg O.D./2.121" Stack-up		A-1	A / B	PT266
	4 OSR > 1.063" Brg O.D/ 3.217" Stack-up		A-1	A / B	PT521HD
1975 ALL V-8 MODELS	4 ISR > 1.078" Brg O.D./2.121" Stack-up		A-1	A / B	PT266
	4 OSR > 1.063" Brg O.D/ 3.217" Stack-up		A-1	A / B	PT521HD
ALL 6 CYL. MODELS	4 OSR > 1.063" Brg O.D/ 3.217" Stack-up		A-1	A / B	PT521HD
	4 OSR > 1.063" Brg O.D./2.437" Stack-up		A-1	A / B	PT315
70-74 All Models	4 OSR > 1.063" Brg O.D/ 3.217" Stack-up		A-1	A / B	PT521HD
MATADOR					
75-78 All Models	4 ISR > 1.078" Brg O.D./2.121" Stack-up		A-1	A / B	PT266
	4 OSR > 1.063" Brg O.D/ 3.217" Stack-up		A-1	A / B	PT521HD
70-74 All Models	4 OSR > 1.063" Brg O.D/ 3.217" Stack-up		A-1	A / B	PT521HD
PACER					
79-80 All Models	4 ISR > 1.078" Brg O.D./2.121" Stack-up		A-1	A	PT266
	4 OSR > 1.063" Brg O.D/ 3.217" Stack-up		A-1	A / B	PT521HD
	4 ISR > 1.078"/1.125" Brg O.D./2.121"/2.362" Stack-up		A-1	B	PT353
75-78 All Models	4 ISR > 1.078" Brg O.D./2.121" Stack-up		A-1	A / B	PT266
	4 OSR > 1.063" Brg O.D/ 3.217" Stack-up		A-1	A / B	PT521HD

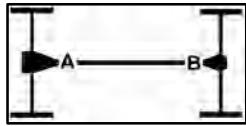

APPLICATION A-1

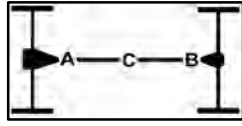

APPLICATION B-1

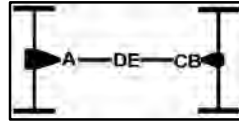

APPLICATION C-1

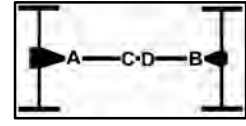

APPLICATION D-1

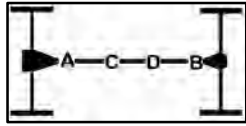

APPLICATION E-1

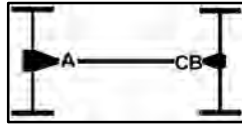

APPLICATION F-1

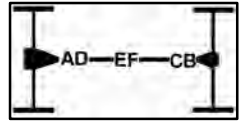

APPLICATION H-1

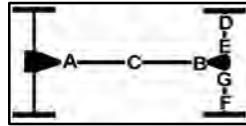

APPLICATION I-1

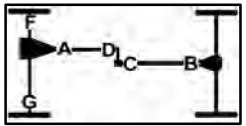

APPLICATION K-1

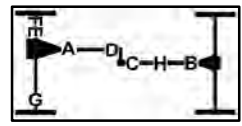

APPLICATION L-1

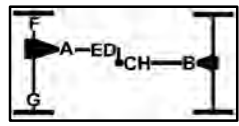

APPLICATION N-1



APPLICATION O-1

MAKE/YEARS FITMENT U-JOINT DESCRIPTION LOCATION POSITION PART NO.

AMERICAN MOTORS (AMC)

AMERICAN MOTORS (AMC)

SPIRIT					
79-83	All Models	4 ISR > 1.078" Brg O.D./2.121" Stack-up	A-1	A / B	PT266
		4 OSR > 1.063" Brg O.D/ 3.217" Stack-up	A-1	A / B	PT521HD
		4 ISR > 1.078"/1.125" Brg O.D./2.121"/2.362" Stack-up	A-1	B	PT353
SUMMIT					
89-96	All Models - AWD	4 OSR > .985" Brg O.D./2.498" Stack-up	F-1	A / C / B	PT1601
TALON					
90-95	All Models - AWD	4 OSR > .985" Brg O.D./2.498" Stack-up	F-1	A / C / B	PT1601

BUICK

BUICK

APOLLO					
73-75	All Models	4 OSR > 1.063" Brg O.D/ 3.217" Stack-up	A-1	A / B	PT521HD
CENTURY					
73-81	All Models	4 ISR > 1.125" Brg O.D./2.555 Stack-up	A-1	A / B	PT3105
CENTURION					
71-73	All Models	4 ISR > 1.125" Brg O.D./2.555 Stack-up	F-1	A / B / C	PT3105
ELECTRA					
70-89	All Models - 2 Joint Shaft	4 ISR > 1.125" Brg O.D./2.555 Stack-up	A-1	A / B	PT3105
		4 OSR > 1.188" Brg O.D./3.622" Stack-up	A-1	A / B	PT578
		All Models - 3 Joint Shaft	4 ISR > 1.125" Brg O.D./2.555 Stack-up	F-1	A / B / C
ESTATE WAGON					
1990	All Models	4 ISR > 1.125" Brg O.D./2.555 Stack-up	A-1	A / B	PT3105
LESABRE					
70-89	All Models - 2 Joint Shaft	4 ISR > 1.125" Brg O.D./2.555 Stack-up	A-1	A / B	PT3105
		4 OSR > 1.188" Brg O.D./3.622" Stack-up	A-1	A / B	PT578
		All Models - 3 Joint Shaft	4 ISR > 1.125" Brg O.D./2.555 Stack-up	F-1	A / B / C
RANIER 2WD					
04-06	All Models	4 ISR > 1.125" Brg O.D./2.555 Stack-up	A-1	A / B	PT3105

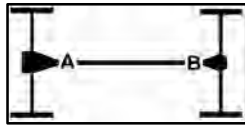

APPLICATION A-1

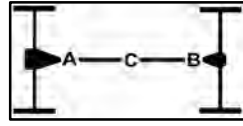

APPLICATION B-1

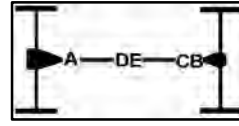

APPLICATION C-1

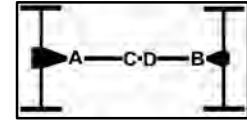

APPLICATION D-1

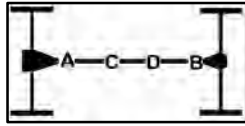

APPLICATION E-1

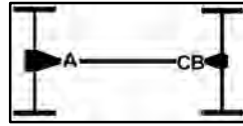

APPLICATION F-1

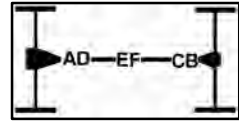

APPLICATION H-1

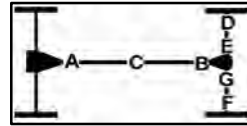

APPLICATION I-1

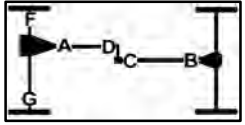

APPLICATION K-1

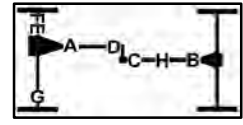

APPLICATION L-1

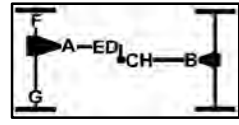

APPLICATION N-1

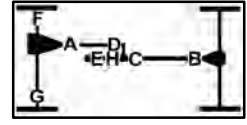

APPLICATION O-1

MAKE/YEARS FITMENT U-JOINT DESCRIPTION LOCATION POSITION PART NO.

BUICK

BUICK

MAKE/YEARS	FITMENT	U-JOINT DESCRIPTION	LOCATION	POSITION	PART NO.
RANIER 4WD					
04-06	All Models	2 ISR & 2 OSR > 1.063" Brg O.D/ 3.217" OSR - 2.344" ISR Stack-up	L-1	A	PT445
		4 ISR > 1.125" Brg O.D./2.555 Stack-up	L-1	C / B	PT3105
REGAL					
82-87	All Models	4 ISR > 1.125" Brg O.D./2.555 Stack-up	A-1	A / B	PT3105
		4 OSR > 1.188" Brg O.D./3.622" Stack-up	A-1	A / B	PT578
77-81	All Models	4 ISR > 1.125" Brg O.D./2.555 Stack-up	A-1	A / B	PT3105
RIVIERA					
70-78	All Models-All Locations	4 ISR > 1.125" Brg O.D./2.555 Stack-up			PT3105
ROADMASTER					
91-96	All Models	4 ISR > 1.125" Brg O.D./2.555 Stack-up	A-1	A / B	PT3105
SKYHAWK					
75-80	All Models	4 OSR > 1.063" Brg O.D/ 3.217" Stack-up	A-1	A / B	PT521HD
SKYLARK					
75-98	All Models	4 ISR > 1.125" Brg O.D./2.555 Stack-up	A-1	A / B	PT3105
		4 OSR > 1.063" Brg O.D/ 3.217" Stack-up	A-1	A / B	PT521HD
70-72	All Models	4 ISR > 1.125" Brg O.D./2.555 Stack-up	A-1	A / B	PT3105
		4 OSR > 1.063" Brg O.D/ 3.217" Stack-up	A-1	A / B	PT521HD
WILDCAT					
1970	All Models	4 ISR > 1.125" Brg O.D./2.555 Stack-up	A-1	A / B	PT3105

CADILLAC

CADILLAC

MAKE/YEARS	FITMENT	U-JOINT DESCRIPTION	LOCATION	POSITION	PART NO.
BROUGHMAN					
89-92	All Models	4 ISR > 1.125" Brg O.D./2.555 Stack-up	A-1	A / B	PT3105
CALAIS					
70-76	All Models - 2 Kits At Each Location	4 ISR > 1.125" Brg O.D./2.555 Stack-up	A-1	A / B	PT3105

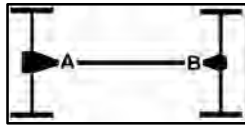

APPLICATION A-1

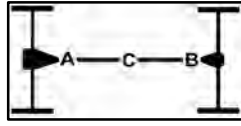

APPLICATION B-1

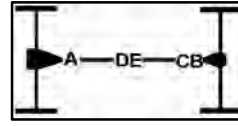

APPLICATION C-1

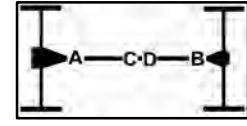

APPLICATION D-1

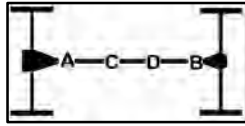

APPLICATION E-1

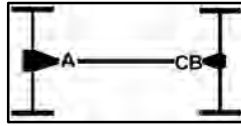

APPLICATION F-1

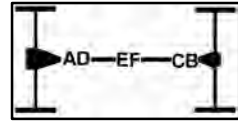

APPLICATION H-1

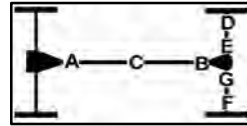

APPLICATION I-1

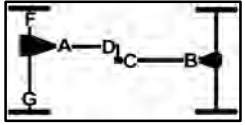

APPLICATION K-1

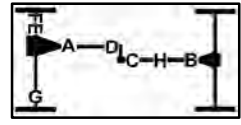

APPLICATION L-1

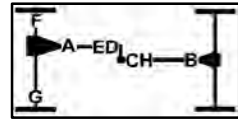

APPLICATION N-1

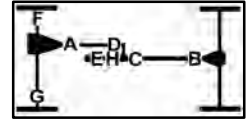

APPLICATION O-1

MAKE/YEARS FITMENT U-JOINT DESCRIPTION LOCATION POSITION PART NO.

CADILLAC

CADILLAC

DEVILLE					
82-84	All Models	4 ISR > 1.125" Brg O.D./2.555 Stack-up	A-1	A / B	PT3105
		4 OSR > 1.188" Brg O.D./3.622" Stack-up	A-1	A / B	PT578
70-81	All Models-Application contains two kits in rear	4 ISR > 1.125" Brg O.D./2.555 Stack-up	H-1	A / B / D / E / F	PT3105
		ESCALADE 2WD			
05-06	All Models	4 OSR > 1.188" Brg O.D./3.622" Stack-up	A-1	A / B	PT578
		4 ISR > 1.125" Brg O.D./2.555 Stack-up	A-1	A / B	PT3105
02-04	All Models	4 ISR > 1.125" Brg O.D./2.555 Stack-up	A-1	A / B	PT3105
		ESCALADE 4WD			
02-06	All Models	4 ISR > 1.125" Brg O.D./2.555 Stack-up	K-1	A / B / C / D	PT3105
		99-00	All Models	4 ISR > 1.125" Brg O.D./2.555 Stack-up	K-1
FLEETWOOD					
70-96	All Models - All Locations	4 ISR > 1.125" Brg O.D./2.555 Stack-up			PT3105
		SEVILLE			
76-79	All Models	4 ISR > 1.125" Brg O.D./2.555 Stack-up	F-1	A / B / C	PT3105

CHEVROLET

CHEVROLET

ASTRO VAN FWD					
04-05	All Models	4 ISR > 1.125" Brg O.D./2.555 Stack-up	A-1	A	PT3105
		85-03	All Models	4 ISR > 1.125" Brg O.D./2.555 Stack-up	A-1
		4 OSR > 1.188" Brg O.D./3.622" Stack-up	A-1	B	PT578
ASTRO VAN AWD					
04-05	All Models	2 ISR & 2 OSR > 1.063" Brg O.D/ 3.217" OSR - 2.344" ISR Stack-up	L-1	A	PT445
		4 ISR > 1.125" Brg O.D./2.555 Stack-up	L-1	C / B	PT3105
85-03	All Models	4 ISR > 1.125" Brg O.D./2.555 Stack-up	K-1	C	PT3105
		4 OSR > 1.188" Brg O.D./3.622" Stack-up	K-1	B	PT578
AVALANCHE 1500 1/2 TON 2WD					
02-06	All Models	4 OSR > 1.063" Brg O.D/ 3.622" Stack-up	A-1	A	PT530
		2 ISR & 2 OSR > 1.063"/1.125" Brg O.D/ 2.555" ISR	A-1	B	PT3188

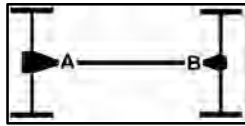

APPLICATION A-1

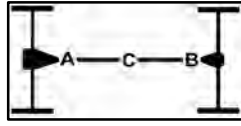

APPLICATION B-1

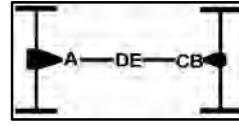

APPLICATION C-1

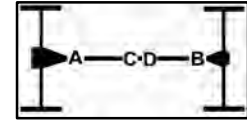

APPLICATION D-1

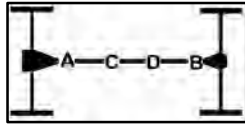

APPLICATION E-1

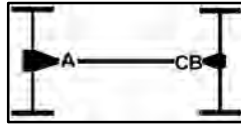

APPLICATION F-1

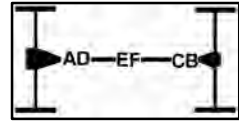

APPLICATION H-1

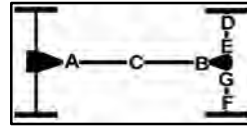

APPLICATION I-1

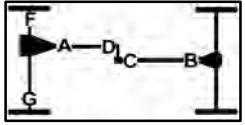

APPLICATION K-1

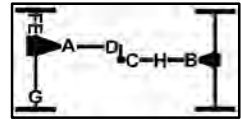

APPLICATION L-1

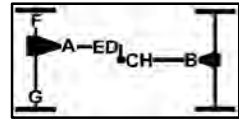

APPLICATION N-1

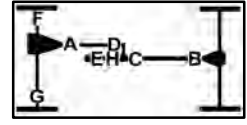

APPLICATION O-1

MAKE/YEARS FITMENT U-JOINT DESCRIPTION LOCATION POSITION PART NO.

CHEVROLET

CHEVROLET

MAKE/YEARS	FITMENT	U-JOINT DESCRIPTION	LOCATION	POSITION	PART NO.
AVALANCHE 1500 1/2 TON 4WD					
02-06	All Models	4 ISR > 1.125" Brg O.D./2.555 Stack-up	K-1	A / B / C / D	PT3105
AVALANCHE 2500 3/4 TON 2WD					
02-06	All Models	4 OSR > 1.188" Brg O.D./4.182" Stack-up	A-1	A / B	PT560
AVALANCHE 2500 3/4 TON 4WD					
02-06	All Models	4 ISR > 1.125" Brg O.D./2.555 Stack-up	K-1	A / D	PT3105
		4 OSR > 1.188" Brg O.D./4.182" Stack-up	K-1	B / C	PT560
BEL AIR					
73-77	All Models	4 ISR > 1.125" Brg O.D./2.555 Stack-up	A-1	A / B	PT3105
71-72	All Models	4 ISR > 1.125" Brg O.D./2.555 Stack-up	F-1	A	PT3105
		4 OSR > 1.063" Brg O.D/ 3.217" Stack-up	F-1	B / C	PT521HD
1970	All Models	4 ISR > 1.125" Brg O.D./2.555 Stack-up	A-1	A	PT3105
		2 ISR & 2 OSR > 1.063"/1.125" Brg O.D/ 2.555" ISR	A-1	B	PT3188
		4 OSR > 1.063" Brg O.D/ 3.217" Stack-up	A-1	A / B	PT521HD
BISCAYNE, BROOKWOOD					
71-72	All Models	4 ISR > 1.125" Brg O.D./2.555 Stack-up	F-1	A	PT3105
		4 OSR > 1.063" Brg O.D/ 3.217" Stack-up	F-1	B / C	PT521HD
1970	All Models	4 ISR > 1.125" Brg O.D./2.555 Stack-up	A-1	A	PT3105
		2 ISR & 2 OSR > 1.063"/1.125" Brg O.D/ 2.555" ISR	A-1	B	PT3188
		4 OSR > 1.063" Brg O.D/ 3.217" Stack-up	A-1	A / B	PT521HD
BLAZER (FULL SIZE) 2WD					
70-94	All Models	4 ISR > 1.125" Brg O.D./2.555 Stack-up	A-1	A / B	PT3105
70-81	All Models	4 OSR > 1.063" Brg O.D/ 3.217" Stack-up	A-1	A / B	PT521HD
		4 OSR > 1.188" Brg O.D./3.622" Stack-up	A-1	A	PT578
BLAZER (FULL SIZE) 4WD					
1994	All Models	2 ISR & 2 OSR > 1.063"/1.125" Brg O.D/ 2.555" ISR	K-1	A	PT3188
		4 OSR > 1.063" Brg O.D/ 3.622" Stack-up	K-1	D	PT530
		4 ISR > 1.125" Brg O.D./2.555 Stack-up	K-1	C / B	PT3105
92-93	All Models	4 ISR > 1.125" Brg O.D./2.555 Stack-up	K-1	A / D / C / B	PT3105

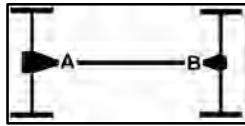

APPLICATION A-1

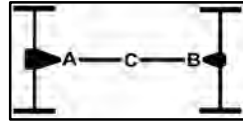

APPLICATION B-1

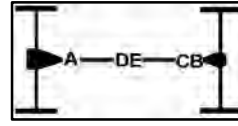

APPLICATION C-1

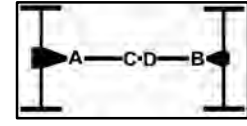

APPLICATION D-1

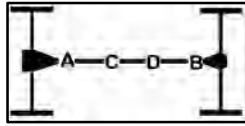

APPLICATION E-1

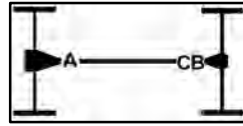

APPLICATION F-1

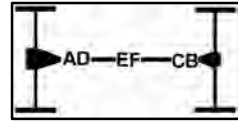

APPLICATION H-1

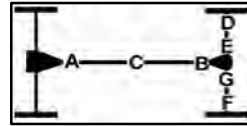

APPLICATION I-1

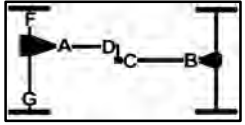

APPLICATION K-1

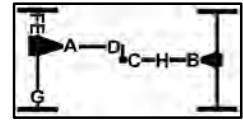

APPLICATION L-1

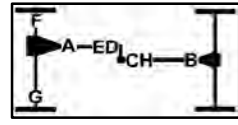

APPLICATION N-1

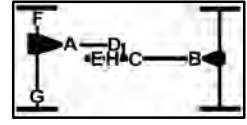

APPLICATION O-1

MAKE/YEARS FITMENT U-JOINT DESCRIPTION LOCATION POSITION PART NO.

CHEVROLET

CHEVROLET

BLAZER (FULL SIZE) 4WD					
82-91 All Models - 4 Spd. M/T	4 ISR > 1.125" Brg O.D./2.555 Stack-up	N-1	E / D	PT3105	
	4 OSR > 1.063" Brg O.D/ 3.217" Stack-up	N-1	A	PT521HD	
	4 OSR > 1.188" Brg O.D./3.622" Stack-up	N-1	C / B	PT578	
	4 ISR > 1.188" Brg O.D./2.187" Stack-up	N-1	F / G	PT297	
All Models - Exc. 4 Spd. M/T	4 ISR > 1.125" Brg O.D./2.555 Stack-up	N-1	E / D	PT3105	
	4 OSR > 1.063" Brg O.D/ 3.217" Stack-up	N-1	A	PT521HD	
	4 ISR > 1.125" Brg O.D./2.555 Stack-up	N-1	C / B	PT3105	
	4 ISR > 1.188" Brg O.D./2.187" Stack-up	N-1	F / G	PT297	
72-81 All Models	4 ISR > 1.125" Brg O.D./2.555 Stack-up	N-1	E / D	PT3105	
	4 OSR > 1.063" Brg O.D/ 3.217" Stack-up	N-1	A / C / B	PT521HD	
	4 ISR > 1.188" Brg O.D./2.187" Stack-up	N-1	F / G	PT297	
70-71 All Models	4 OSR > 1.063" Brg O.D/ 3.217" Stack-up	N-1	A / E / D / C / B	PT521HD	
	4 ISR > 1.063" Brg O.D/2.183" Stack-up	N-1	F / G	PT260	
C10 1/2 TON PICKUP 2WD					
82-86 All Models-2 Joint Driveshaft	4 ISR > 1.125" Brg O.D./2.555 Stack-up	A-1	A / B	PT3105	
All Models-3 Joint Driveshaft	4 ISR > 1.125" Brg O.D./2.555 Stack-up	B-1	A / B / C	PT3105	
	4 OSR > 1.188" Brg O.D./3.622" Stack-up	B-1	A / B / C	PT578	
79-81 All Models-2 Joint Driveshaft	4 OSR > 1.063" Brg O.D/ 3.217" Stack-up	A-1	A / B	PT521HD	
All Models-3 Joint Driveshaft	4 OSR > 1.063" Brg O.D/ 3.217" Stack-up	B-1	A / B / C	PT521HD	
	4 OSR > 1.188" Brg O.D./3.622" Stack-up	B-1	A / B / C	PT578	
	2 ISR & 2 OSR > 1.063"/1.125" Brg O.D/ 2.555" ISR	B-1	B	PT3188	
1978 All Models-With 2 Joint Driveshaft	4 OSR > 1.063" Brg O.D/ 3.217" Stack-up	A-1	A / B	PT521HD	
All Models-With 3 Joint Driveshaft; Turbo	4 OSR > 1.188" Brg O.D./3.622" Stack-up	B-1	A / B	PT578	
	4 ISR > 1.125" Brg O.D./2.555 Stack-up	B-1	C	PT3105	
All Models-With 3 Joint Driveshaft; Exc. Turbo	4 OSR > 1.063" Brg O.D/ 3.217" Stack-up	B-1	A / B / C	PT521HD	
70-77 All Models-2 Joint Driveshaft	4 OSR > 1.188" Brg O.D./3.622" Stack-up	A-1	A	PT578	
	4 OSR > 1.063" Brg O.D/ 3.622" Stack-up	A-1	A	PT530	
	4 OSR > 1.063" Brg O.D/ 3.217" Stack-up	A-1	A / B	PT521HD	

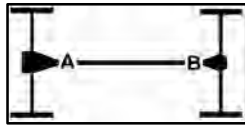

APPLICATION A-1

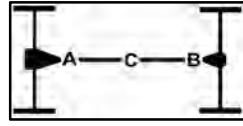

APPLICATION B-1

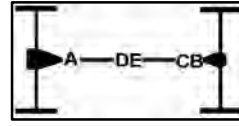

APPLICATION C-1

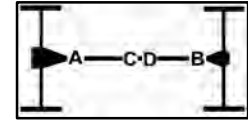

APPLICATION D-1

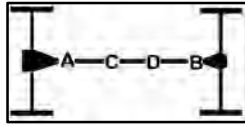

APPLICATION E-1

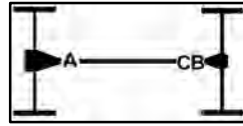

APPLICATION F-1

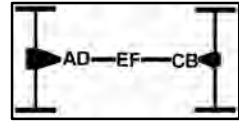

APPLICATION H-1

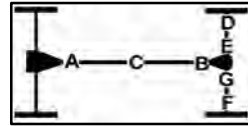

APPLICATION I-1

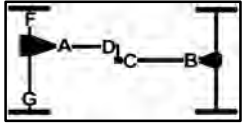

APPLICATION K-1

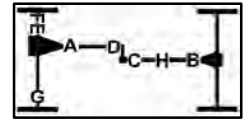

APPLICATION L-1

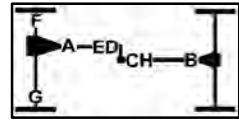

APPLICATION N-1



APPLICATION O-1

MAKE/YEARS FITMENT U-JOINT DESCRIPTION LOCATION POSITION PART NO.

CHEVROLET

CHEVROLET

MAKE/YEARS	FITMENT	U-JOINT DESCRIPTION	LOCATION	POSITION	PART NO.
C10 1/2 TON PICKUP 2WD					
70-77	All Models-3	Joint Driveshaft			
		4 OSR > 1.063" Brg O.D./ 3.217" Stack-up	B-1	A / B / C	PT521HD
		4 OSR > 1.188" Brg O.D./3.622" Stack-up	B-1	A / B / C	PT578
		4 OSR > 1.063" Brg O.D/ 3.622" Stack-up	B-1	A / B	PT530
C20 3/4 TON PICKUP 2WD					
82-86	All Models				
		4 OSR > 1.188" Brg O.D./3.622" Stack-up	B-1	A / B / C	PT578
		4 ISR > 1.125" Brg O.D./2.555 Stack-up	B-1	A / B / C	PT3105
1981	All Models-2 Door				
		4 OSR > 1.188" Brg O.D./3.622" Stack-up	B-1	A / C	PT578
		4 ISR > 1.125" Brg O.D./2.555 Stack-up	B-1	B	PT3105
		4 OSR > 1.063" Brg O.D/ 3.217" Stack-up	B-1	A / C	PT521HD
	All Models-4 Door				
		4 OSR > 1.188" Brg O.D./3.622" Stack-up	B-1	A / B / C	PT578
		4 OSR > 1.063" Brg O.D/ 3.217" Stack-up	B-1	C	PT521HD
70-80	All Models				
		4 OSR > 1.188" Brg O.D./3.622" Stack-up	B-1	A / B / C	PT578
		4 OSR > 1.063" Brg O.D/ 3.217" Stack-up	B-1	A / B / C	PT521HD
		4 OSR > 1.063" Brg O.D/ 3.622" Stack-up	B-1	A	PT530
C30 1 TON PICKUP 2WD					
79-86	All Models				
		4 OSR > 1.188" Brg O.D./3.622" Stack-up	B-1	A / B / C	PT578
70-78	All Models				
		4 OSR > 1.063" Brg O.D/ 3.217" Stack-up	B-1	A / C	PT521HD
		4 OSR > 1.063" Brg O.D/ 3.622" Stack-up	B-1	A	PT530
		4 OSR > 1.188" Brg O.D./3.622" Stack-up	B-1	A / B / C	PT578
C1500 1/2 TON PICKUP 2WD					
96-99	All Models-Regular Cab; Short Bed				
		4 ISR > 1.125" Brg O.D./2.555 Stack-up	A-1	A / B	PT3105
	All Models-Regular Cab-Long Bed or Ext. Cab-M/T				
		4 OSR > 1.063" Brg O.D/ 3.622" Stack-up	B-1	A / C	PT530
		2 ISR & 2 OSR > 1.063"/1.125" Brg O.D/ 2.555" ISR	B-1	B	PT3188
	All Models-Ext. Cab; A/T				
		4 OSR > 1.188" Brg O.D./3.622" Stack-up	B-1	A / B / C	PT578
92-95	All Models-Regular Cab; Short Bed; Exc. A/T				
		4 ISR > 1.125" Brg O.D./2.555 Stack-up	A-1	A / B	PT3105
	All Models-Regular Cab; Short Bed; A/T				
		4 OSR > 1.188" Brg O.D./3.622" Stack-up	A-1	A / B	PT578
	All Models-Regular Cab; Long Bed-A/T or M/T-Exc. Heavy Duty				
		4 OSR > 1.063" Brg O.D/ 3.622" Stack-up	A-1	A	PT530
		2 ISR & 2 OSR > 1.063"/1.125" Brg O.D/ 2.555" ISR	A-1	B	PT3188

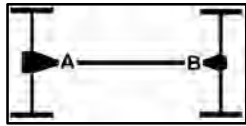

APPLICATION A-1

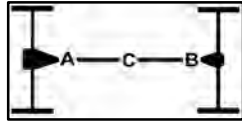

APPLICATION B-1

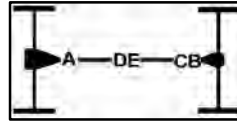

APPLICATION C-1

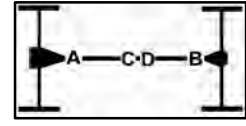

APPLICATION D-1

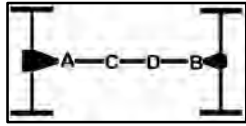

APPLICATION E-1

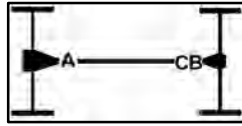

APPLICATION F-1

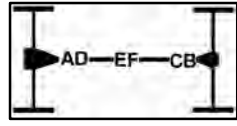

APPLICATION H-1

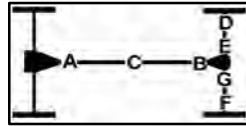

APPLICATION I-1

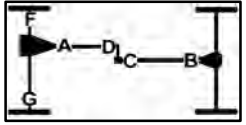

APPLICATION K-1

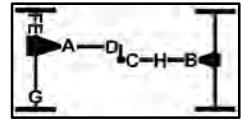

APPLICATION L-1

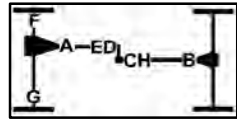

APPLICATION N-1



APPLICATION O-1

MAKE/YEARS FITMENT U-JOINT DESCRIPTION LOCATION POSITION PART NO.

CHEVROLET

CHEVROLET

MAKE/YEARS	FITMENT	U-JOINT DESCRIPTION	LOCATION	POSITION	PART NO.
C1500 1/2 TON PICKUP 2WD					
92-95	All Models-Regular or Extended Cab; M/T; Heavy Duty	4 OSR > 1.188" Brg O.D./3.622" Stack-up	B-1	A / B / C	PT578
	All Models-Extended Cab; A/T	4 ISR > 1.125" Brg O.D./2.555 Stack-up	B-1	A / B / C	PT3105
	All Models-Extended Cab; M/T; Exc. Heavy Duty or Turbo Diesel Engine	4 OSR > 1.063" Brg O.D/ 3.622" Stack-up	B-1	A / C	PT530
		2 ISR & 2 OSR > 1.063"/1.125" Brg O.D/ 2.555" ISR	B-1	B	PT3188
88-91	All Models-2 Joint Driveshaft; Regular Cab	4 OSR > 1.188" Brg O.D./3.622" Stack-up	A-1	A / B	PT578
		4 ISR > 1.125" Brg O.D./2.555 Stack-up	A-1	A / B	PT3105
		4 OSR > 1.063" Brg O.D/ 3.622" Stack-up	A-1	A	PT530
		2 ISR & 2 OSR > 1.063"/1.125" Brg O.D/ 2.555" ISR	A-1	B	PT3188
	All Models-3 Joint Driveshaft-Regular Cab or Extended Cab-5 Spd. M/T	4 OSR > 1.188" Brg O.D./3.622" Stack-up	B-1	A / B / C	PT578
	All Models-Extended Cab; A/T	4 ISR > 1.125" Brg O.D./2.555 Stack-up	B-1	A / B / C	PT3105
		4 OSR > 1.188" Brg O.D./3.622" Stack-up	B-1	C	PT578
	All Models-Extended Cab; 5 Spd. M/T	4 OSR > 1.063" Brg O.D/ 3.622" Stack-up	B-1	A / C	PT530
		2 ISR & 2 OSR > 1.063"/1.125" Brg O.D/ 2.555" ISR	B-1	B	PT3188
C1500 1/2 TON SUBURBAN 2WD					
96-99	All Models-Diesel	4 OSR > 1.188" Brg O.D./3.622" Stack-up	A-1	A / B	PT578
	All Models-Exc. Diesel	4 OSR > 1.063" Brg O.D/ 3.622" Stack-up	A-1	A	PT530
		2 ISR & 2 OSR > 1.063"/1.125" Brg O.D/ 2.555" ISR	A-1	B	PT3188
1995	All Models-With 4 Speed Transmission	4 OSR > 1.188" Brg O.D./3.622" Stack-up	A-1	A / B	PT578
	All Models-Without 4 Speed Transmission	4 OSR > 1.063" Brg O.D/ 3.622" Stack-up	A-1	A	PT530
		2 ISR & 2 OSR > 1.063"/1.125" Brg O.D/ 2.555" ISR	A-1	B	PT3188
1994	All Models	4 OSR > 1.063" Brg O.D/ 3.622" Stack-up	A-1	A	PT530
		2 ISR & 2 OSR > 1.063"/1.125" Brg O.D/ 2.555" ISR	A-1	B	PT3188
C2500 3/4 TON PICKUP 2WD					
88-00	All Models	4 OSR > 1.188" Brg O.D./3.622" Stack-up	B-1	A / B / C	PT578
C2500 3/4 TON SUBURBAN 2WD					
94-99	All Models	4 OSR > 1.188" Brg O.D./3.622" Stack-up	B-1	A / B	PT578

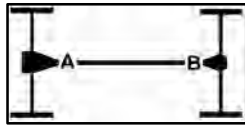

APPLICATION A-1

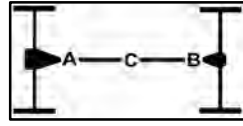

APPLICATION B-1

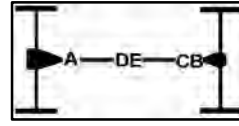

APPLICATION C-1

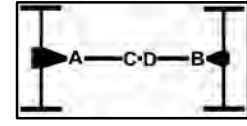

APPLICATION D-1

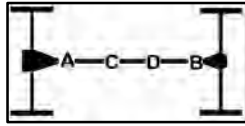

APPLICATION E-1

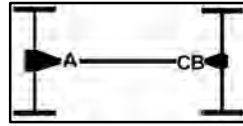

APPLICATION F-1

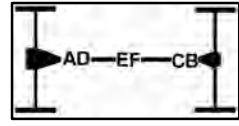

APPLICATION H-1

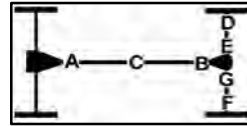

APPLICATION I-1

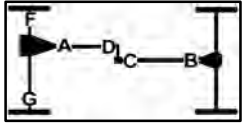

APPLICATION K-1

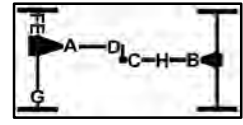

APPLICATION L-1

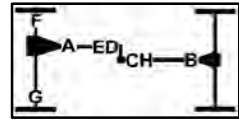

APPLICATION N-1

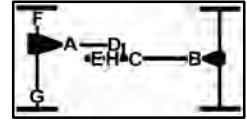

APPLICATION O-1

MAKE/YEARS FITMENT U-JOINT DESCRIPTION LOCATION POSITION PART NO.

CHEVROLET

CHEVROLET

MAKE/YEARS	FITMENT	U-JOINT DESCRIPTION	LOCATION	POSITION	PART NO.
C3500 1 TON PICKUP/SUBURBAN 2WD					
88-00 All Models-3 or 4 Joint Driveshaft					
		4 OSR > 1.188" Brg O.D./3.622" Stack-up	B-1	A / B / C	PT578
		4 OSR > 1.188" Brg O.D./4.182" Stack-up	C-1	A / B / C / D	PT560
C3500HD 1 TON PICKUP 2WD					
2002 All Models-2 or 3 Joint Driveshaft					
		4 OSR > 1.188" Brg O.D./4.182" Stack-up	B-1	A / B / C	PT560
91-01 All Models-3 or 4 Joint Driveshaft					
		4 OSR > 1.188" Brg O.D./4.182" Stack-up	C-1	A / B / C / D	PT560
		4 OSR > 1.188" Brg O.D./3.622" Stack-up	C-1	A / B / C / D	PT578
CAMARO					
93-02 All Models					
		4 ISR > 1.125" Brg O.D./2.555 Stack-up	A-1	A / B	PT3105
70-92 All Models					
		4 ISR > 1.125" Brg O.D./2.555 Stack-up	A-1	A / B	PT3105
		4 OSR > 1.188" Brg O.D./3.622" Stack-up	A-1	A / B	PT578
		4 OSR > 1.063" Brg O.D/ 3.217" Stack-up	A-1	A / B	PT521HD
CAPRICE					
82-96 All Models					
		4 ISR > 1.125" Brg O.D./2.555 Stack-up	A-1	A / B	PT3105
		4 OSR > 1.188" Brg O.D./3.622" Stack-up	A-1	A / B	PT578
73-81 All Models					
		4 ISR > 1.125" Brg O.D./2.555 Stack-up	A-1	A / B	PT3105
71-72 All Models					
		4 ISR > 1.125" Brg O.D./2.555 Stack-up	F-1	A	PT3105
		4 OSR > 1.063" Brg O.D/ 3.217" Stack-up	F-1	B / C	PT521HD
1970 All Models					
		4 ISR > 1.125" Brg O.D./2.555 Stack-up	A-1	A	PT3105
		2 ISR & 2 OSR > 1.063"/1.125" Brg O.D/ 2.555" ISR	A-1	B	PT3188
		4 OSR > 1.063" Brg O.D/ 3.217" Stack-up	A-1	A / B	PT521HD
CHEVELLE					
1973 All Models					
		4 ISR > 1.125" Brg O.D./2.555 Stack-up	A-1	A / B	PT3105
71-72 All Models - 7.4L V8					
		4 ISR > 1.125" Brg O.D./2.555 Stack-up	A-1	A	PT3105
		2 ISR & 2 OSR > 1.063"/1.125" Brg O.D/ 2.555" ISR	A-1	B	PT3188
All Models - Exc. 7.4L V8					
		4 OSR > 1.063" Brg O.D/ 3.217" Stack-up	A-1	A / B	PT521HD
1970 All Models					
		4 OSR > 1.063" Brg O.D/ 3.217" Stack-up	A-1	A / B	PT521HD
CHEVETTE					
76-87 All Models					
		4 ISR > 1.063" Brg O.D./2.341" Stack-up	A-1	A / B	PT350

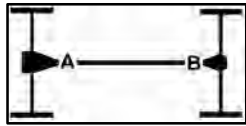

APPLICATION A-1

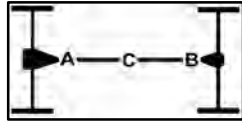

APPLICATION B-1

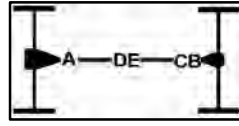

APPLICATION C-1

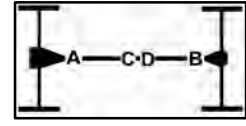

APPLICATION D-1

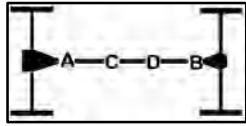

APPLICATION E-1

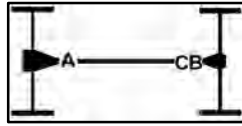

APPLICATION F-1

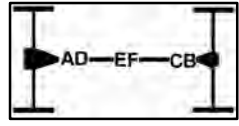

APPLICATION H-1

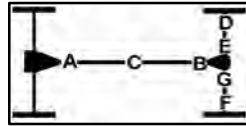

APPLICATION I-1

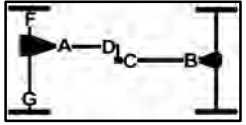

APPLICATION K-1

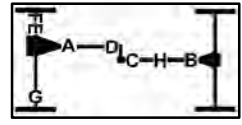

APPLICATION L-1

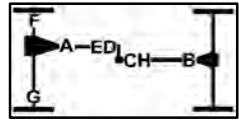

APPLICATION N-1



APPLICATION O-1

MAKE/YEARS FITMENT U-JOINT DESCRIPTION LOCATION POSITION PART NO.

CHEVROLET

CHEVROLET

MAKE/YEARS	FITMENT	U-JOINT DESCRIPTION	LOCATION	POSITION	PART NO.
COLORADO 2WD					
04-06	All Models	4 OSR > 1.063" Brg O.D/ 3.622" Stack-up	B-1	A / B	PT530
		2 ISR & 2 OSR > 1.063"/1.125" Brg O.D/ 2.555" ISR	B-1	B / C	PT3188
COLORADO 4WD					
04-06	All Models	4 OSR > 1.063" Brg O.D/ 3.217" Stack-up	K-1	A	PT521HD
		4 OSR > 1.063" Brg O.D/ 3.622" Stack-up	K-1	B / C	PT530
		2 ISR & 2 OSR > 1.063"/1.125" Brg O.D/ 2.555" ISR	K-1	B	PT3188
CORVETTE					
84-99	All Models	4 OSR > 1.063" Brg O.D/ 3.217" Stack-up	I-1	A / B	PT521HD
		4 OSR > 1.188" Brg O.D./3.622" Stack-up	I-1	D / E / F / G	PT578
80-82	All Models-Auto Transmission	4 OSR > 1.063" Brg O.D/ 3.622" Stack-up	I-1	All Locations	PT530
	All Models-Manual Transmission	4 OSR > 1.063" Brg O.D/ 3.217" Stack-up	I-1	A / B	PT521HD
		4 OSR > 1.188" Brg O.D./3.622" Stack-up	I-1	D / E / F / G	PT578
71-79	All Models	4 OSR > 1.063" Brg O.D/ 3.622" Stack-up	I-1	A / B	PT530
		4 OSR > 1.188" Brg O.D./3.622" Stack-up	I-1	D / E / F / G	PT578
1970	All Models-Auto Transmission	4 OSR > 1.063" Brg O.D/ 3.622" Stack-up	I-1	A / B	PT530
		4 OSR > 1.188" Brg O.D./3.622" Stack-up	I-1	D / E / F / G	PT578
	All Models-Manual Transmission	4 ISR > 1.063" Brg O.D/ 3.622" Stack-up	I-1	A / B	PT521HD
		4 OSR > 1.188" Brg O.D./3.622" Stack-up	I-1	D / E / F / G	PT578
EL CAMINO					
73-87	All Models	4 ISR > 1.125" Brg O.D./2.555 Stack-up	A-1	A / B	PT3105
		4 OSR > 1.063" Brg O.D/ 3.217" Stack-up	A-1	A / B	PT521HD
70-72	All Models	4 OSR > 1.063" Brg O.D/ 3.217" Stack-up	A-1	A / B	PT521HD
EXPRESS 1500 1/2 TON VAN 2WD					
03-06	All Models	4 OSR > 1.188" Brg O.D./3.622" Stack-up	A-1	A / B	PT578
EXPRESS 1500 1/2 TON VAN 4WD					
03-06	All Models	4 ISR > 1.125" Brg O.D./2.555 Stack-up	K-1	A / D	PT3105
		4 OSR > 1.188" Brg O.D./3.622" Stack-up	K-1	B / C	PT578

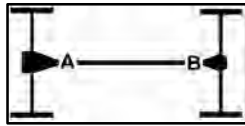

APPLICATION A-1

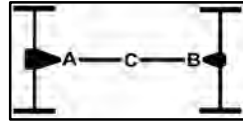

APPLICATION B-1

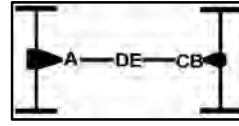

APPLICATION C-1

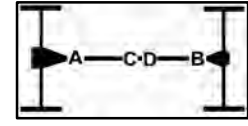

APPLICATION D-1

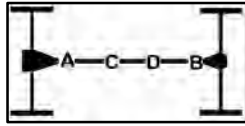

APPLICATION E-1

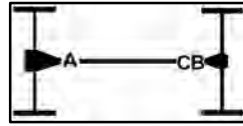

APPLICATION F-1

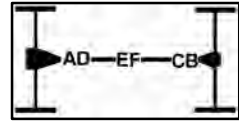

APPLICATION H-1

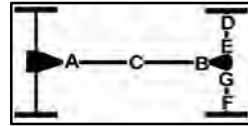

APPLICATION I-1

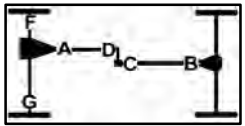

APPLICATION K-1

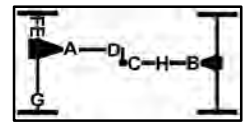

APPLICATION L-1

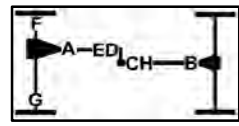

APPLICATION N-1



APPLICATION O-1

MAKE/YEARS FITMENT U-JOINT DESCRIPTION LOCATION POSITION PART NO.

CHEVROLET

CHEVROLET

MAKE/YEARS	FITMENT	U-JOINT DESCRIPTION	LOCATION	POSITION	PART NO.
EXPRESS 2500 3/4 TON VAN 2WD					
03-06	All Models-2	Joint Driveshaft 4 OSR > 1.188" Brg O.D./3.622" Stack-up	A-1	A / B	PT578
	All Models-3	Joint Driveshaft 4 OSR > 1.188" Brg O.D./3.622" Stack-up	B-1	A / B / C	PT578
EXPRESS 2500 3/4 TON VAN 4WD					
03-06	All Models	4 ISR > 1.125" Brg O.D./2.555 Stack-up	K-1	A / B / C / D	PT3105
		4 OSR > 1.188" Brg O.D./3.622" Stack-up	K-1	B / C	PT578
EXPRESS 3500 1 TON VAN 2WD					
03-06	All Models-2 or 3	Joint Driveshaft 4 OSR > 1.188" Brg O.D./4.182" Stack-up	B-1	A / B / C	PT560
		4 OSR > 1.188" Brg O.D./3.622" Stack-up	B-1	A / B / C	PT578
G10 1/2 TON VAN 2WD					
91-95	All Models-2	Joint Driveshaft; 110" WB 4 ISR > 1.125" Brg O.D./2.555 Stack-up	A-1	A / B	PT3105
	All Models-2	Joint Driveshaft; 120" WB 4 OSR > 1.063" Brg O.D/ 3.622" Stack-up	A-1	A	PT530
		2 ISR & 2 OSR > 1.063"/1.125" Brg O.D/ 2.555" ISR	A-1	B	PT3188
	All Models-2	Joint Driveshaft; 135" WB 4 OSR > 1.188" Brg O.D./3.622" Stack-up	A-1	A / B	PT578
	All Models-3	Joint Driveshaft 4 ISR > 1.125" Brg O.D./2.555 Stack-up	B-1	A / B / C	PT3105
70-90	All Models-2	Joint Driveshaft 4 OSR > 1.063" Brg O.D/ 3.217" Stack-up	A-1	A / B	PT521HD
		4 ISR > 1.125" Brg O.D./2.555 Stack-up	A-1	A / B	PT3105
	All Models-3	Joint Driveshaft 4 ISR > 1.125" Brg O.D./2.555 Stack-up	B-1	A / B / C	PT3105
		4 OSR > 1.063" Brg O.D/ 3.217" Stack-up	B-1	A / B / C	PT521HD
		4 OSR > 1.188" Brg O.D./3.622" Stack-up	B-1	B / C	PT578
G20 3/4 TON VAN 2WD					
91-95	All Models-2	Joint Driveshaft 4 ISR > 1.125" Brg O.D./2.555 Stack-up	A-1	A / B	PT3105
		4 OSR > 1.063" Brg O.D/ 3.622" Stack-up	A-1	A	PT530
		2 ISR & 2 OSR > 1.063"/1.125" Brg O.D/ 2.555" ISR	A-1	B	PT3188
82-90	All Models-2 or 3	Joint Driveshaft 4 ISR > 1.125" Brg O.D./2.555 Stack-up	B-1	A / B / C	PT3105

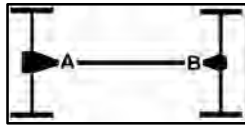

APPLICATION A-1

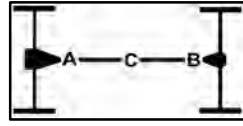

APPLICATION B-1

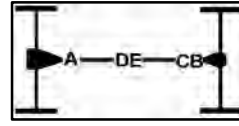

APPLICATION C-1

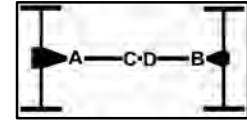

APPLICATION D-1

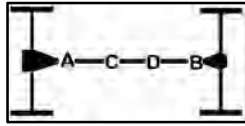

APPLICATION E-1

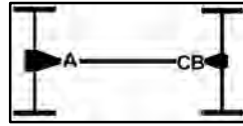

APPLICATION F-1

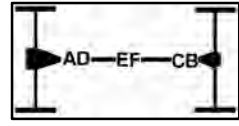

APPLICATION H-1

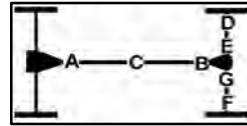

APPLICATION I-1

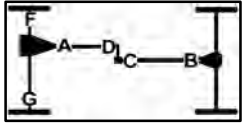

APPLICATION K-1

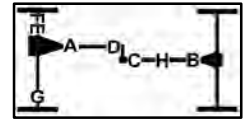

APPLICATION L-1

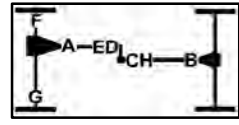

APPLICATION N-1

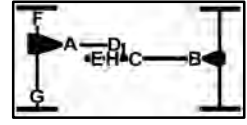

APPLICATION O-1

MAKE/YEARS FITMENT U-JOINT DESCRIPTION LOCATION POSITION PART NO.

CHEVROLET

CHEVROLET

G20 3/4 TON VAN 2WD					
1981 All Models-2 Joint Driveshaft	4 ISR > 1.125" Brg O.D./2.555 Stack-up	A-1	A / B	PT3105	
	4 OSR > 1.063" Brg O.D/ 3.217" Stack-up	A-1	A / B	PT521HD	
	All Models-3 Joint Driveshaft				
	4 ISR > 1.125" Brg O.D./2.555 Stack-up	B-1	A	PT3105	
	4 OSR > 1.188" Brg O.D./3.622" Stack-up	B-1	B / C	PT578	
	4 OSR > 1.063" Brg O.D/ 3.217" Stack-up	B-1	B / C	PT521HD	
76-80 All Models-2 Joint Driveshaft; V-8 400 Sm Blk	4 ISR > 1.125" Brg O.D./2.555 Stack-up	A-1	A	PT3105	
	2 ISR & 2 OSR > 1.063"/1.125" Brg O.D/ 2.555" ISR	A-1	B	PT3188	
	All Models-2 or 3 Joint Driveshaft; Exc. V-8 400 Sm Blk				
	4 OSR > 1.063" Brg O.D/ 3.217" Stack-up	B-1	A / B / C	PT521HD	
	4 ISR > 1.125" Brg O.D./2.555 Stack-up	B-1	A / B / C	PT3105	
	All Models-3 Joint Driveshaft; V-8 400 Sm Blk				
	4 ISR > 1.125" Brg O.D./2.555 Stack-up	B-1	A	PT3105	
	4 OSR > 1.063" Brg O.D/ 3.622" Stack-up	B-1	B	PT530	
	4 OSR > 1.188" Brg O.D./3.622" Stack-up	B-1	C	PT578	
70-75 All Models	4 OSR > 1.063" Brg O.D/ 3.217" Stack-up	B-1	A / B / C	PT521HD	
G30 1 TON VAN 2WD					
91-96 All Models-2 or 3 Joint Driveshaft	4 OSR > 1.188" Brg O.D./3.622" Stack-up	B-1	A / B / C	PT578	
	80-90 All Models				
	4 ISR > 1.125" Brg O.D./2.555 Stack-up	B-1	A	PT3105	
	4 OSR > 1.188" Brg O.D./3.622" Stack-up	B-1	A / B / C	PT578	
78-79 All Models-2 Joint Driveshaft	4 OSR > 1.188" Brg O.D./3.622" Stack-up	A-1	A / B	PT578	
	All Models-3 Joint Driveshaft				
	4 ISR > 1.125" Brg O.D./2.555 Stack-up	B-1	A	PT3105	
	4 OSR > 1.188" Brg O.D./3.622" Stack-up	B-1	A / B / C	PT578	
75-77 All Models-2 or 3 Joint Driveshaft	4 OSR > 1.063" Brg O.D/ 3.622" Stack-up	B-1	A	PT530	
	4 OSR > 1.063" Brg O.D/ 3.217" Stack-up	B-1	A / B	PT521HD	
	4 OSR > 1.188" Brg O.D./3.622" Stack-up	B-1	B / C	PT578	
70-74 All Models-2 or 3 Joint Driveshaft	4 OSR > 1.063" Brg O.D/ 3.217" Stack-up	B-1	A / B / C	PT521HD	
G1500 1/2 TON VAN 2WD					
97-02 All Models	4 OSR > 1.188" Brg O.D./3.622" Stack-up	A-1	A / B	PT578	

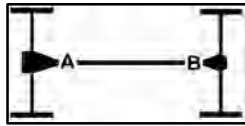

APPLICATION A-1

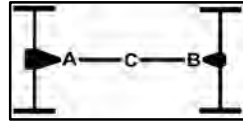

APPLICATION B-1

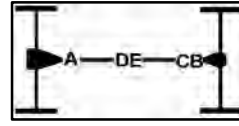

APPLICATION C-1

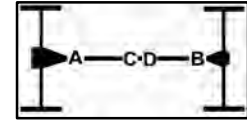

APPLICATION D-1

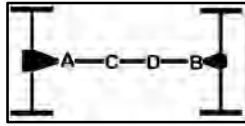

APPLICATION E-1

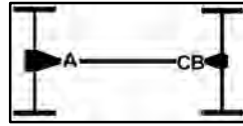

APPLICATION F-1

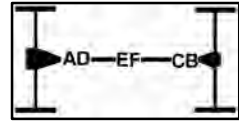

APPLICATION H-1

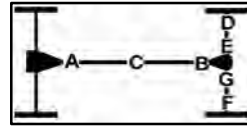

APPLICATION I-1

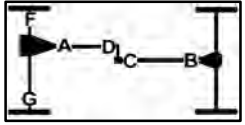

APPLICATION K-1

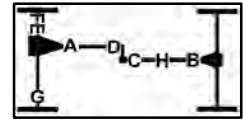

APPLICATION L-1

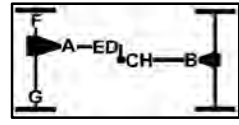

APPLICATION N-1

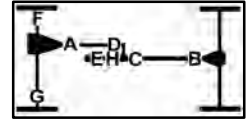

APPLICATION O-1

MAKE/YEARS FITMENT U-JOINT DESCRIPTION LOCATION POSITION PART NO.

CHEVROLET

CHEVROLET

MAKE/YEARS	FITMENT	U-JOINT DESCRIPTION	LOCATION	POSITION	PART NO.
G1500 1/2 TON VAN 2WD					
1996	All Models-2	Joint Driveshaft; 110" WB 4 ISR > 1.125" Brg O.D./2.555 Stack-up	A-1	A / B	PT3105
	All Models-2	Joint Driveshaft; 120" WB 4 OSR > 1.063" Brg O.D/ 3.622" Stack-up	A-1	A	PT530
		2 ISR & 2 OSR > 1.063"/1.125" Brg O.D/ 2.555" ISR	A-1	B	PT3188
	All Models-2	Joint Driveshaft; 135" WB 4 OSR > 1.188" Brg O.D./3.622" Stack-up	A-1	A / B	PT578
	All Models-3	Joint Driveshaft 4 ISR > 1.125" Brg O.D./2.555 Stack-up	B-1	A / B / C	PT3105
G2500 3/4 TON VAN 2WD					
96-02	All Models-2 or 3	Joint Driveshaft 4 ISR > 1.125" Brg O.D./2.555 Stack-up	B-1	A / B / C	PT3105
		4 OSR > 1.188" Brg O.D./3.622" Stack-up	B-1	A / B / C	PT578
G3500 1 TON VAN 2WD					
96-02	All Models-2 or 3	Joint Driveshaft 4 OSR > 1.188" Brg O.D./3.622" Stack-up	B-1	A / B / C	PT578
		4 OSR > 1.188" Brg O.D./4.182" Stack-up	B-1	A / B / C	PT560
IMPALA					
94-96	All Models	4 ISR > 1.125" Brg O.D./2.555 Stack-up	A-1	A / B	PT3105
82-85	All Models	4 ISR > 1.125" Brg O.D./2.555 Stack-up	A-1	A / B	PT3105
		4 OSR > 1.188" Brg O.D./3.622" Stack-up	A-1	A / B	PT578
71-81	All Models	4 ISR > 1.125" Brg O.D./2.555 Stack-up	F-1	A / B / C	PT3105
1970	All Models	4 ISR > 1.125" Brg O.D./2.555 Stack-up	A-1	A	PT3105
		2 ISR & 2 OSR > 1.063"/1.125" Brg O.D/ 2.555" ISR	A-1	B	PT3188
		4 OSR > 1.063" Brg O.D/ 3.217" Stack-up	A-1	A / B	PT521HD
K10 1/2 TON PICKUP 4WD					
82-86	All Models	4 OSR > 1.063" Brg O.D/ 3.217" Stack-up	N-1	A	PT521HD
		4 ISR > 1.125" Brg O.D./2.555 Stack-up	N-1	B / C / D / E	PT3105
		4 OSR > 1.188" Brg O.D./3.622" Stack-up	N-1	B / H	PT578
		4 ISR > 1.188" Brg O.D./2.187" Stack-up	N-1	F / G	PT297
79-81	All Models	4 ISR > 1.125" Brg O.D./2.555 Stack-up	N-1	D / E	PT3105
		4 OSR > 1.063" Brg O.D/ 3.217" Stack-up	N-1	A / B / C	PT521HD
		4 ISR > 1.188" Brg O.D./2.187" Stack-up	N-1	F / G	PT297

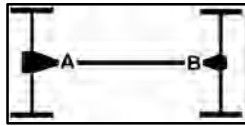

APPLICATION A-1

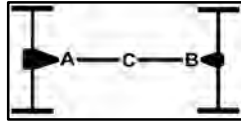

APPLICATION B-1

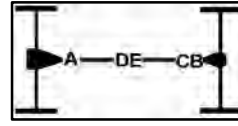

APPLICATION C-1

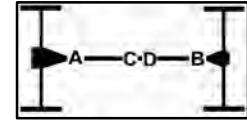

APPLICATION D-1

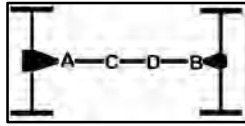

APPLICATION E-1

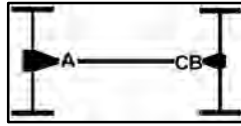

APPLICATION F-1

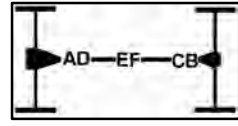

APPLICATION H-1

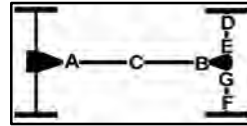

APPLICATION I-1

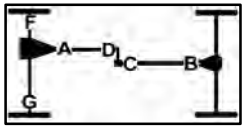

APPLICATION K-1

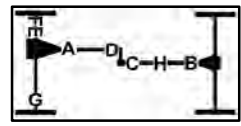

APPLICATION L-1

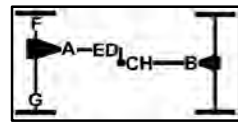

APPLICATION N-1



APPLICATION O-1

MAKE/YEARS FITMENT U-JOINT DESCRIPTION LOCATION POSITION PART NO.

CHEVROLET

CHEVROLET

MAKE/YEARS	FITMENT	U-JOINT DESCRIPTION	LOCATION	POSITION	PART NO.
K10 1/2 TON PICKUP 4WD					
1978	All Models	4 ISR > 1.125" Brg O.D./2.555 Stack-up	N-1	D / E	PT3105
		4 OSR > 1.063" Brg O.D/ 3.217" Stack-up	N-1	A / B / C / D / E	PT521HD
		4 OSR > 1.188" Brg O.D./3.622" Stack-up	N-1	B / H	PT578
		4 ISR > 1.188" Brg O.D./2.187" Stack-up	N-1	F / G	PT297
70-77	All Models	4 OSR > 1.063" Brg O.D/ 3.217" Stack-up	N-1	A / B / C / D / E	PT521HD
		4 ISR > 1.063" Brg O.D/2.183" Stack-up	N-1	F / G	PT260
		4 ISR > 1.188" Brg O.D./2.187" Stack-up	N-1	F / G	PT297
K20 3/4 TON PICKUP 4WD					
77-86	All Models	4 ISR > 1.125" Brg O.D./2.555 Stack-up	N-1	D / E	PT3105
		4 OSR > 1.063" Brg O.D/ 3.217" Stack-up	N-1	A / C / D / E	PT521HD
		4 OSR > 1.188" Brg O.D./3.622" Stack-up	N-1	B / C / H	PT578
		4 ISR > 1.188" Brg O.D./2.187" Stack-up	N-1	F / G	PT297
70-76	All Models	4 OSR > 1.063" Brg O.D/ 3.217" Stack-up	N-1	A / B / C / D / E	PT521HD
		4 OSR > 1.188" Brg O.D./3.622" Stack-up	N-1	B / C / H	PT578
		4 ISR > 1.063" Brg O.D/2.183" Stack-up	N-1	F / G	PT260
		4 ISR > 1.188" Brg O.D./2.187" Stack-up	N-1	F / G	PT297
K30 1 TON PICKUP 4WD					
80-86	All Models	4 ISR > 1.125" Brg O.D./2.555 Stack-up	N-1	D / E	PT3105
		4 OSR > 1.063" Brg O.D/ 3.217" Stack-up	N-1	A	PT521HD
		4 OSR > 1.188" Brg O.D./3.622" Stack-up	N-1	B / C / H	PT578
		4 ISR > 1.375" Brg O.D./2.995" Stack-up	N-1	F / G	PT332
1979	All Models	4 OSR > 1.063" Brg O.D/ 3.217" Stack-up	N-1	C / D / E	PT521HD
		4 OSR > 1.188" Brg O.D./3.622" Stack-up	N-1	A / B / C / H	PT578
		4 ISR > 1.375" Brg O.D./2.995" Stack-up	N-1	F / G	PT332
77-78	All Models	4 OSR > 1.063" Brg O.D/ 3.217" Stack-up	L-1	A / D	PT521HD
		4 OSR > 1.188" Brg O.D./3.622" Stack-up	L-1	C / B / H	PT578
		4 ISR > 1.375" Brg O.D./2.995" Stack-up	L-1	F / G	PT332
K1500 1/2 TON PICKUP 4WD					
92-99	All Models - 6.2L or 6.5L DSL	2 ISR & 2 OSR > 1.063"/1.125" Brg O.D/ 2.555" ISR	L-1	A	PT3188
		4 OSR > 1.063" Brg O.D/ 3.622" Stack-up	L-1	D	PT530
		All Models - Exc. 6.2L or 6.5L DSL			
		4 ISR > 1.125" Brg O.D./2.555 Stack-up	L-1	A / D	PT3105

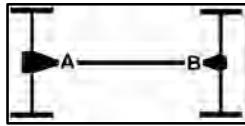

APPLICATION A-1

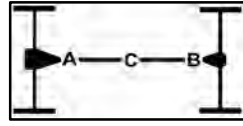

APPLICATION B-1

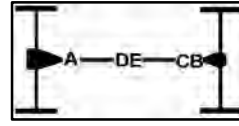

APPLICATION C-1

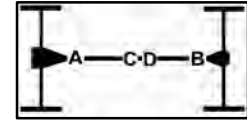

APPLICATION D-1

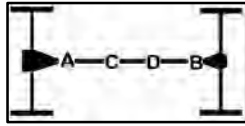

APPLICATION E-1

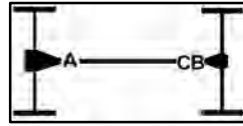

APPLICATION F-1

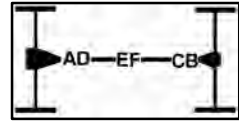

APPLICATION H-1

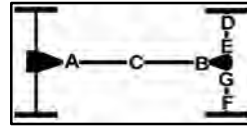

APPLICATION I-1

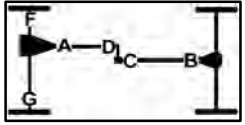

APPLICATION K-1

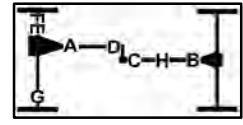

APPLICATION L-1

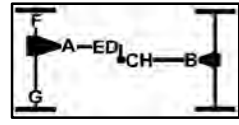

APPLICATION N-1

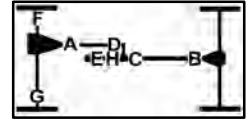

APPLICATION O-1

MAKE/YEARS FITMENT U-JOINT DESCRIPTION LOCATION POSITION PART NO.

CHEVROLET

CHEVROLET

MAKE/YEARS	FITMENT	U-JOINT DESCRIPTION	LOCATION	POSITION	PART NO.	
K1500 1/2 TON PICKUP 4WD						
92-99	All Models - Regular Cab	4 ISR > 1.125" Brg O.D./2.555 Stack-up	L-1	B / C	PT3105	
		4 OSR > 1.188" Brg O.D./3.622" Stack-up	L-1	B / C	PT578	
	All Models - Extended Cab	4 OSR > 1.063" Brg O.D/ 3.622" Stack-up	L-1	C / H	PT530	
		2 ISR & 2 OSR > 1.063"/1.125" Brg O.D/ 2.555" ISR	L-1	B	PT3188	
		4 OSR > 1.188" Brg O.D./3.622" Stack-up	L-1	C / B / H	PT578	
	88-91	All Models - A/T	4 ISR > 1.125" Brg O.D./2.555 Stack-up	L-1	A / D	PT3105
			All Models - M/T	2 ISR & 2 OSR > 1.063"/1.125" Brg O.D/ 2.555" ISR	L-1	A
		4 OSR > 1.063" Brg O.D/ 3.622" Stack-up		L-1	D	PT530
		All Models - Regular Cab A/T	4 ISR > 1.125" Brg O.D./2.555 Stack-up	L-1	B / C	PT3105
			All Models - Regular Cab M/T	4 OSR > 1.188" Brg O.D./3.622" Stack-up	L-1	B / C
All Models - Extended Cab A/T		4 OSR > 1.063" Brg O.D/ 3.622" Stack-up		L-1	C / H	PT530
		2 ISR & 2 OSR > 1.063"/1.125" Brg O.D/ 2.555" ISR	L-1	B	PT3188	
		All Models - Extended Cab M/T	4 OSR > 1.188" Brg O.D./3.622" Stack-up	L-1	C / B / H	PT578
K2500 3/4 TON PICKUP 4WD						
92-99		All Models - 6.2L or 6.5L DSL	2 ISR & 2 OSR > 1.063"/1.125" Brg O.D/ 2.555" ISR	L-1	A	PT3188
	4 OSR > 1.063" Brg O.D/ 3.622" Stack-up		L-1	D	PT530	
	All Models - Exc. 6.2L or 6.5L DSL	4 ISR > 1.125" Brg O.D./2.555 Stack-up	L-1	A / D	PT3105	
		All Models	4 OSR > 1.188" Brg O.D./3.622" Stack-up	L-1	C / B / H	PT578
	88-91	All Models - A/T	4 ISR > 1.125" Brg O.D./2.555 Stack-up	L-1	A / D	PT3105
			All Models - M/T	2 ISR & 2 OSR > 1.063"/1.125" Brg O.D/ 2.555" ISR	L-1	A
4 OSR > 1.063" Brg O.D/ 3.622" Stack-up		L-1		D	PT530	
All Models		4 OSR > 1.188" Brg O.D./3.622" Stack-up	L-1	C / B / H	PT578	
K3500 1 TON PICKUP 4WD						
92-99	All Models	4 ISR > 1.125" Brg O.D./2.555 Stack-up	L-1	A / D	PT3105	
		4 OSR > 1.188" Brg O.D./3.622" Stack-up	L-1	C / B / H	PT578	

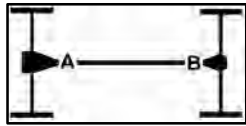

APPLICATION A-1

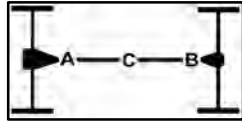

APPLICATION B-1

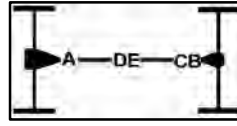

APPLICATION C-1

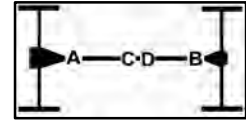

APPLICATION D-1

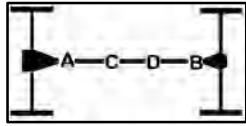

APPLICATION E-1

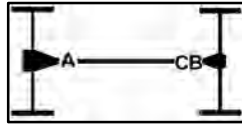

APPLICATION F-1

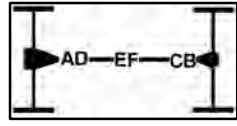

APPLICATION H-1

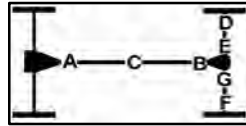

APPLICATION I-1

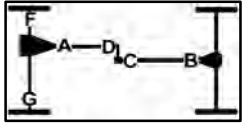

APPLICATION K-1

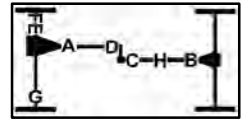

APPLICATION L-1

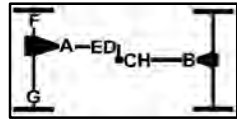

APPLICATION N-1



APPLICATION O-1

MAKE/YEARS FITMENT U-JOINT DESCRIPTION LOCATION POSITION PART NO.

CHEVROLET

CHEVROLET

MAKE/YEARS	FITMENT	U-JOINT DESCRIPTION	LOCATION	POSITION	PART NO.
K3500 1 TON PICKUP 4WD					
88-91	All Models - 2 Door	4 ISR > 1.125" Brg O.D./2.555 Stack-up	N-1	A / D	PT3105
		2 ISR & 2 OSR > 1.063"/1.125" Brg O.D/ 2.555" ISR	N-1	A	PT3188
		4 OSR > 1.063" Brg O.D/ 3.622" Stack-up	N-1	D	PT530
		4 OSR > 1.188" Brg O.D./3.622" Stack-up	N-1	C / B / H	PT578
	All Models - 4 Door	4 ISR > 1.125" Brg O.D./2.555 Stack-up	N-1	D / E	PT3105
		4 OSR > 1.063" Brg O.D/ 3.217" Stack-up	N-1	A	PT521HD
		4 OSR > 1.188" Brg O.D./3.622" Stack-up	N-1	C / B / H	PT578
	All Models	4 ISR > 1.375" Brg O.D./2.995" Stack-up	N-1	F / G	PT332
LUV PICKUP 2WD					
72-82	All Models	4 OSR > .938" Brg O.D./2.407" Stack-up	B-1	A / B / C	PT514
LUV PICKUP 4WD					
72-82	All Models	4 ISR > 1.142" Brg O.D./2.089" Stack-up	L-1	A / D	PT1621
		4 OSR > .938" Brg O.D./2.407" Stack-up	L-1	A / C / H / B	PT514
MALIBU					
82-83	All Models	4 ISR > 1.125" Brg O.D./2.555 Stack-up	A-1	A / B	PT3105
		4 OSR > 1.188" Brg O.D./3.622" Stack-up	A-1	A / B	PT578
73-81	All Models	4 ISR > 1.125" Brg O.D./2.555 Stack-up	A-1	A / B	PT3105
MONTE CARLO					
85-88	All Models	4 ISR > 1.125" Brg O.D./2.555 Stack-up	A-1	A / B	PT3105
82-84	All Models	4 ISR > 1.125" Brg O.D./2.555 Stack-up	A-1	A / B	PT3105
		4 OSR > 1.188" Brg O.D./3.622" Stack-up	A-1	A / B	PT578
73-81	All Models	4 ISR > 1.125" Brg O.D./2.555 Stack-up	A-1	A / B	PT3105
71-72	All Models - 7.4L V8	4 ISR > 1.125" Brg O.D./2.555 Stack-up	A-1	A	PT3105
		2 ISR & 2 OSR > 1.063"/1.125" Brg O.D/ 2.555" ISR	A-1	B	PT3188
	All Models - Exc. 7.4L V8	4 OSR > 1.063" Brg O.D/ 3.217" Stack-up	A-1	A / B	PT521HD
1970	All Models	4 OSR > 1.063" Brg O.D/ 3.217" Stack-up	A-1	A / B	PT521HD
MONZA					
75-80	All Models	4 OSR > 1.063" Brg O.D/ 3.217" Stack-up	A-1	A / B	PT521HD

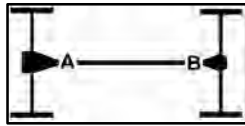

APPLICATION A-1

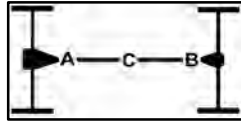

APPLICATION B-1

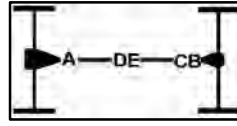

APPLICATION C-1

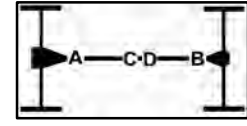

APPLICATION D-1

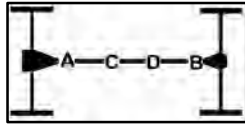

APPLICATION E-1

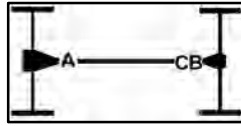

APPLICATION F-1

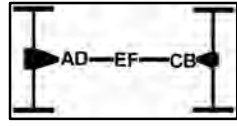

APPLICATION H-1

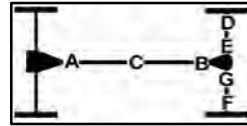

APPLICATION I-1

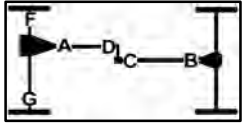

APPLICATION K-1

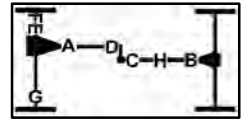

APPLICATION L-1

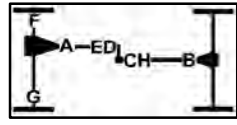

APPLICATION N-1

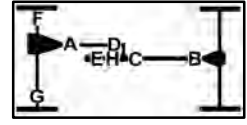

APPLICATION O-1

MAKE/YEARS FITMENT U-JOINT DESCRIPTION LOCATION POSITION PART NO.

CHEVROLET

CHEVROLET

MAKE/YEARS	FITMENT	U-JOINT DESCRIPTION	LOCATION	POSITION	PART NO.
NOVA					
70-79	All Models	4 OSR > 1.063" Brg O.D./ 3.217" Stack-up	A-1	A / B	PT521HD
P10 1/2 TON VAN 2WD					
70-89 All Models-2 Joint Driveshaft					
		4 OSR > 1.063" Brg O.D./ 3.217" Stack-up	A-1	A / B	PT521HD
		4 ISR > 1.125" Brg O.D./2.555 Stack-up	A-1	A / B	PT3105
All Models-3 Joint Driveshaft					
		4 ISR > 1.125" Brg O.D./2.555 Stack-up	B-1	A / B / C	PT3105
		4 OSR > 1.063" Brg O.D./ 3.217" Stack-up	B-1	A / B / C	PT521HD
		4 OSR > 1.188" Brg O.D./3.622" Stack-up	B-1	B / C	PT578
P20 3/4 TON VAN 2WD					
82-89 All Models-2 or 3 Joint Driveshaft					
		4 ISR > 1.125" Brg O.D./2.555 Stack-up	B-1	A / B / C	PT3105
1981 All Models-2 Joint Driveshaft					
		4 ISR > 1.125" Brg O.D./2.555 Stack-up	A-1	A / B	PT3105
		4 OSR > 1.063" Brg O.D./ 3.217" Stack-up	A-1	A / B	PT521HD
All Models-3 Joint Driveshaft					
		4 ISR > 1.125" Brg O.D./2.555 Stack-up	B-1	A	PT3105
		4 OSR > 1.188" Brg O.D./3.622" Stack-up	B-1	B / C	PT578
		4 OSR > 1.063" Brg O.D./ 3.217" Stack-up	B-1	B / C	PT521HD
76-80 All Models-2 Joint Driveshaft; V-8 400 Sm Blk					
		4 ISR > 1.125" Brg O.D./2.555 Stack-up	A-1	A	PT3105
		2 ISR & 2 OSR > 1.063"/1.125" Brg O.D/ 2.555" ISR	A-1	B	PT3188
All Models-2 or 3 Joint Driveshaft; Exc. V-8 400 Sm Blk					
		4 OSR > 1.063" Brg O.D./ 3.217" Stack-up	B-1	A / B / C	PT521HD
		4 ISR > 1.125" Brg O.D./2.555 Stack-up	B-1	A / B / C	PT3105
All Models-3 Joint Driveshaft; V-8 400 Sm Blk					
		4 ISR > 1.125" Brg O.D./2.555 Stack-up	B-1	A	PT3105
		4 OSR > 1.063" Brg O.D./ 3.622" Stack-up	B-1	B	PT530
		4 OSR > 1.188" Brg O.D./3.622" Stack-up	B-1	C	PT578
70-75 All Models					
		4 OSR > 1.063" Brg O.D./ 3.217" Stack-up	B-1	A / B / C	PT521HD
P30 1 TON VAN 2WD					
91-02 All Models-2 or 3 Joint Driveshaft					
		4 OSR > 1.188" Brg O.D./3.622" Stack-up	B-1	A / B / C	PT578
		4 OSR > 1.188" Brg O.D./4.182" Stack-up	B-1	A / B / C	PT560
80-90 All Models					
		4 ISR > 1.125" Brg O.D./2.555 Stack-up	B-1	A	PT3105
		4 OSR > 1.188" Brg O.D./3.622" Stack-up	B-1	A / B / C	PT578

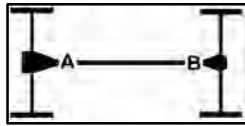

APPLICATION A-1

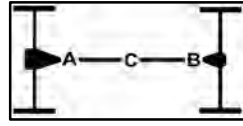

APPLICATION B-1

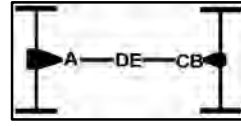

APPLICATION C-1

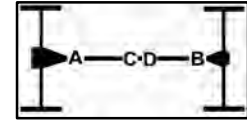

APPLICATION D-1

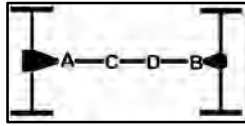

APPLICATION E-1

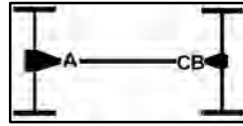

APPLICATION F-1

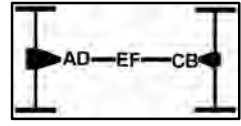

APPLICATION H-1

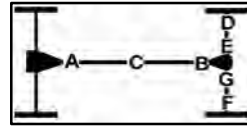

APPLICATION I-1

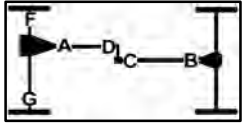

APPLICATION K-1

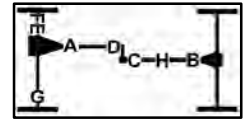

APPLICATION L-1

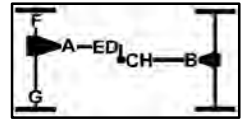

APPLICATION N-1

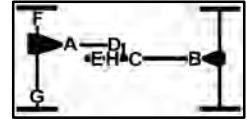

APPLICATION O-1

MAKE/YEARS FITMENT U-JOINT DESCRIPTION LOCATION POSITION PART NO.

CHEVROLET

CHEVROLET

MAKE/YEARS	FITMENT	U-JOINT DESCRIPTION	LOCATION	POSITION	PART NO.
P30 1 TON VAN 2WD					
78-79	All Models-2	Joint Driveshaft 4 OSR > 1.188" Brg O.D./3.622" Stack-up	A-1	A / B	PT578
	All Models-3	Joint Driveshaft 4 ISR > 1.125" Brg O.D./2.555 Stack-up	B-1	A	PT3105
		4 OSR > 1.188" Brg O.D./3.622" Stack-up	B-1	A / B / C	PT578
75-77	All Models-2 or 3	Joint Driveshaft 4 OSR > 1.063" Brg O.D/ 3.622" Stack-up	B-1	A	PT530
		4 OSR > 1.063" Brg O.D/ 3.217" Stack-up	B-1	A / B	PT521HD
		4 OSR > 1.188" Brg O.D./3.622" Stack-up	B-1	B / C	PT578
70-74	All Models-2 or 3	Joint Driveshaft 4 OSR > 1.063" Brg O.D/ 3.217" Stack-up	B-1	A / B / C	PT521HD
R10 1/2 TON PICKUP 2WD					
1987	All Models-2	Joint Driveshaft 4 ISR > 1.125" Brg O.D./2.555 Stack-up	A-1	A / B	PT3105
	All Models-3	Joint Driveshaft 4 ISR > 1.125" Brg O.D./2.555 Stack-up	B-1	A / B / C	PT3105
		4 OSR > 1.188" Brg O.D./3.622" Stack-up	B-1	A / B / C	PT578
R20 3/4 TON PICKUP 2WD					
1988	All Models	4 OSR > 1.188" Brg O.D./3.622" Stack-up	B-1	A / B / C	PT578
1987	All Models	4 OSR > 1.188" Brg O.D./3.622" Stack-up	B-1	A / B / C	PT578
		4 ISR > 1.125" Brg O.D./2.555 Stack-up	B-1	A / C	PT3105
R30 1 TON PICKUP 2WD					
87-88	All Models-3 or 4	Joint Driveshaft 4 OSR > 1.188" Brg O.D./3.622" Stack-up	C-1	A / B / C / D	PT578
R3500 1 TON PICKUP 2WD					
1991	All Models	4 OSR > 1.188" Brg O.D./3.622" Stack-up	B-1	A / B / C	PT578
		4 OSR > 1.188" Brg O.D./4.182" Stack-up	E-1	A / B / C / D	PT560
89-90	All Models	4 OSR > 1.188" Brg O.D./3.622" Stack-up	B-1	A / B / C	PT578
S-10 BLAZER 2WD					
83-05	All Models	4 ISR > 1.125" Brg O.D./2.555 Stack-up	A-1	A / B	PT3105
S-10 BLAZER 4WD					
95-05	All Models	2 ISR & 2 OSR > 1.063" Brg O.D/ 3.217" OSR - 2.344" ISR Stack-up	L-1	A	PT445
		4 ISR > 1.125" Brg O.D./2.555 Stack-up	L-1	C / B	PT3105
		4 OSR > 1.188" Brg O.D./3.622" Stack-up	L-1	C / B	PT578

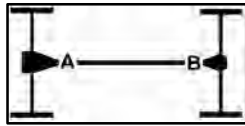

APPLICATION A-1

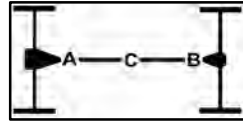

APPLICATION B-1

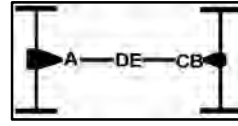

APPLICATION C-1

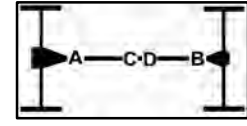

APPLICATION D-1

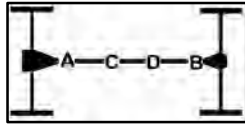

APPLICATION E-1

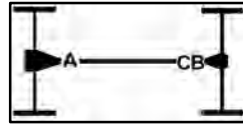

APPLICATION F-1

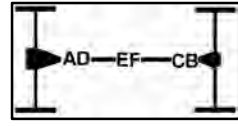

APPLICATION H-1

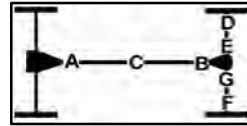

APPLICATION I-1

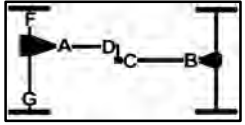

APPLICATION K-1

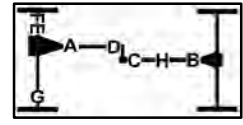

APPLICATION L-1

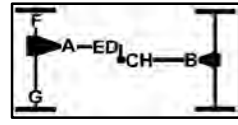

APPLICATION N-1

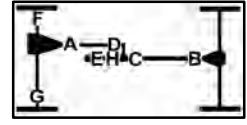

APPLICATION O-1

MAKE/YEARS FITMENT U-JOINT DESCRIPTION LOCATION POSITION PART NO.

CHEVROLET

CHEVROLET

MAKE/YEARS	FITMENT	U-JOINT DESCRIPTION	LOCATION	POSITION	PART NO.
S-10 BLAZER 4WD					
83-94	All Models	4 OSR > 1.063" Brg O.D/ 3.217" Stack-up	L-1	D	PT521HD
		2 ISR & 2 OSR > 1.063" Brg O.D/ 3.217" OSR - 2.188" ISR Stack-up	L-1	A	PT455
		2 ISR & 2 OSR > 1.063" Brg O.D/ 3.217" OSR - 2.344" ISR Stack-up	L-1	A / D	PT445
		4 ISR > 1.125" Brg O.D./2.555 Stack-up	L-1	C / B	PT3105
S-10 PICKUP 2WD					
97-01	All Models	4 ISR > 1.125" Brg O.D./2.555 Stack-up	B-1	A / B / C	PT3105
94-96	All Models-Short Bed or Extended Cab	4 ISR > 1.125" Brg O.D./2.555 Stack-up	B-1	A / B / C	PT3105
	All Models-Long Bed	4 OSR > 1.063" Brg O.D/ 3.622" Stack-up	A-1	A	PT530
		2 ISR & 2 OSR > 1.063"/1.125" Brg O.D/ 2.555" ISR	A-1	B	PT3188
82-93	All Models - 2 or 3 Joint Driveshaft	4 ISR > 1.125" Brg O.D./2.555 Stack-up	B-1	A / B / C	PT3105
S-10 PICKUP 4WD					
95-01	All Models	2 ISR & 2 OSR > 1.063" Brg O.D/ 3.217" OSR - 2.344" ISR Stack-up	L-1	A / D	PT445
		4 ISR > 1.125" Brg O.D./2.555 Stack-up	L-1	B / C	PT3105
		4 OSR > 1.063" Brg O.D/ 3.622" Stack-up	L-1	C	PT530
		2 ISR & 2 OSR > 1.063"/1.125" Brg O.D/ 2.555" ISR	L-1	B	PT3188
88-94	All Models	4 OSR > 1.063" Brg O.D/ 3.217" Stack-up	L-1	D	PT521HD
		2 ISR & 2 OSR > 1.063" Brg O.D/ 3.217" OSR - 2.188" ISR Stack-up	L-1	A	PT455
		2 ISR & 2 OSR > 1.063" Brg O.D/ 3.217" OSR - 2.344" ISR Stack-up	L-1	A / D	PT445
		4 ISR > 1.125" Brg O.D./2.555 Stack-up	L-1	C / B / H	PT3105
82-87	All Models	2 ISR & 2 OSR > 1.063" Brg O.D/ 3.217" OSR - 2.344" ISR Stack-up	L-1	A / D	PT445
		4 ISR > 1.125" Brg O.D./2.555 Stack-up	L-1	C / B / H	PT3105
SILVERADO 1500 1/2 TON PICKUP 2WD					
99-06	All Models w/ Regular Cab	4 ISR > 1.125" Brg O.D./2.555 Stack-up	A-1	A / B	PT3105
		4 OSR > 1.063" Brg O.D/ 3.622" Stack-up	A-1	A	PT530
		2 ISR & 2 OSR > 1.063"/1.125" Brg O.D/ 2.555" ISR	A-1	B	PT3188
	All Models w/ Extended Cab	4 ISR > 1.125" Brg O.D./2.555 Stack-up	B-1	A / B / C	PT3105
		4 OSR > 1.063" Brg O.D/ 3.622" Stack-up	B-1	A / C	PT530
		2 ISR & 2 OSR > 1.063"/1.125" Brg O.D/ 2.555" ISR	B-1	B	PT3188

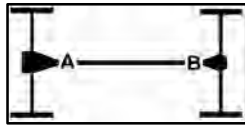

APPLICATION A-1

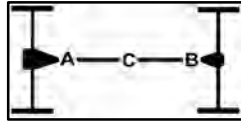

APPLICATION B-1

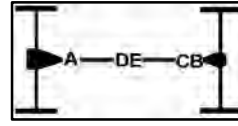

APPLICATION C-1

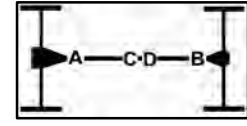

APPLICATION D-1

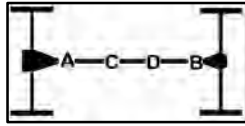

APPLICATION E-1

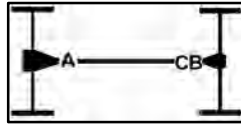

APPLICATION F-1

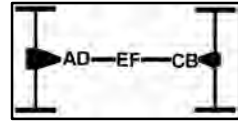

APPLICATION H-1

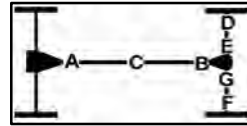

APPLICATION I-1

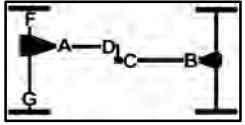

APPLICATION K-1

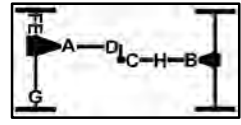

APPLICATION L-1

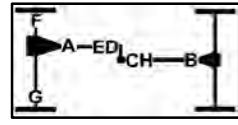

APPLICATION N-1

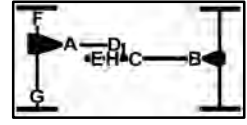

APPLICATION O-1

MAKE/YEARS FITMENT U-JOINT DESCRIPTION LOCATION POSITION PART NO.

CHEVROLET

CHEVROLET

MAKE/YEARS	FITMENT	U-JOINT DESCRIPTION	LOCATION	POSITION	PART NO.
SILVERADO 1500 1/2 TON PICKUP 4WD					
05-06 All Models - Regular Cab					
		4 ISR > 1.125" Brg O.D./2.555 Stack-up	L-1	A / D	PT3105
		4 OSR > 1.188" Brg O.D./3.622" Stack-up	L-1	B / C	PT578
All Models - Extended Cab					
		4 ISR > 1.125" Brg O.D./2.555 Stack-up	L-1	A / D	PT3105
		4 OSR > 1.188" Brg O.D./3.622" Stack-up	L-1	B / C / H	PT578
		4 OSR > 1.063" Brg O.D/ 3.622" Stack-up	L-1	C / H	PT530
		2 ISR & 2 OSR > 1.063"/1.125" Brg O.D/ 2.555" ISR	L-1	B	PT3188
02-04 All Models - Regular Cab					
		4 ISR > 1.125" Brg O.D./2.555 Stack-up	L-1	A / B / C / D	PT3105
All Models - Extended Cab					
		4 ISR > 1.125" Brg O.D./2.555 Stack-up	L-1	A / D	PT3105
		2 ISR & 2 OSR > 1.063"/1.125" Brg O.D/ 2.555" ISR	L-1	B	PT3188
		4 OSR > 1.188" Brg O.D./3.622" Stack-up	L-1	B / C	PT578
		4 OSR > 1.063" Brg O.D/ 3.622" Stack-up	L-1	C / H	PT530
99-01 All Models - Regular Cab					
		4 ISR > 1.125" Brg O.D./2.555 Stack-up	L-1	A / B / C / D	PT3105
All Models - Extended Cab					
		4 ISR > 1.125" Brg O.D./2.555 Stack-up	L-1	A / D	PT3105
		2 ISR & 2 OSR > 1.063"/1.125" Brg O.D/ 2.555" ISR	L-1	B	PT3188
		4 OSR > 1.063" Brg O.D/ 3.622" Stack-up	L-1	C / H	PT530
SILVERADO 2500 3/4 TON PICKUP 2WD					
02-04 All Models					
		4 OSR > 1.188" Brg O.D./3.622" Stack-up	B-1	A / B / C	PT578
99-01 All Models-3 Joint Driveshaft					
		4 OSR > 1.188" Brg O.D./4.182" Stack-up	B-1	A / B / C	PT560
		4 OSR > 1.188" Brg O.D./3.622" Stack-up	B-1	A / B / C	PT578
SILVERADO 2500 3/4 TON PICKUP 4WD					
01-04 All Models					
		4 ISR > 1.125" Brg O.D./2.555 Stack-up	L-1	A / D	PT3105
		4 OSR > 1.188" Brg O.D./3.622" Stack-up	L-1	B / C	PT578
99-00 All Models					
		4 ISR > 1.125" Brg O.D./2.555 Stack-up	L-1	A / D	PT3105
		4 OSR > 1.188" Brg O.D./4.182" Stack-up	L-1	B / C	PT560
		4 OSR > 1.188" Brg O.D./3.622" Stack-up	L-1	B / C / H	PT578
SILVERADO 2500HD 3/4 TON PICKUP 2WD					
01-06 All Models					
		4 OSR > 1.188" Brg O.D./4.182" Stack-up	B-1	A / B / C	PT560
		4 OSR > 1.375" Brg O.D./4.182" Stack-up	B-1	A / B / C	PT588

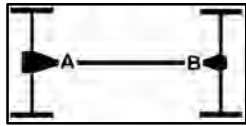

APPLICATION A-1

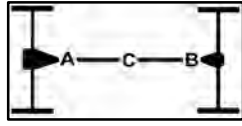

APPLICATION B-1

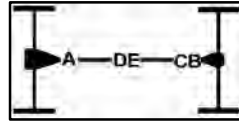

APPLICATION C-1

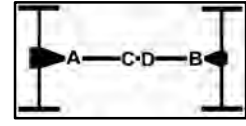

APPLICATION D-1

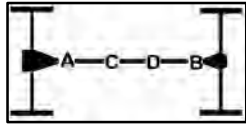

APPLICATION E-1

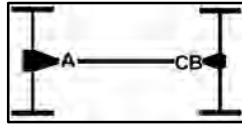

APPLICATION F-1

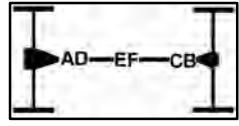

APPLICATION H-1

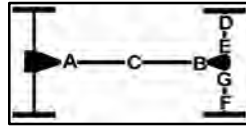

APPLICATION I-1

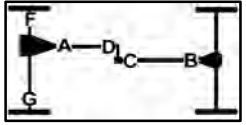

APPLICATION K-1

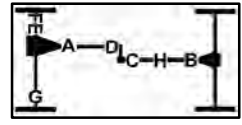

APPLICATION L-1

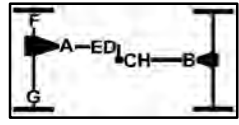

APPLICATION N-1



APPLICATION O-1

MAKE/YEARS FITMENT U-JOINT DESCRIPTION LOCATION POSITION PART NO.

CHEVROLET

CHEVROLET

MAKE/YEARS	FITMENT	U-JOINT DESCRIPTION	LOCATION	POSITION	PART NO.
SILVERADO 2500HD 3/4 TON PICKUP 4WD					
01-06	All Models	4 ISR > 1.125" Brg O.D./2.555 Stack-up	L-1	A / D	PT3105
		4 OSR > 1.188" Brg O.D./4.182" Stack-up	L-1	B / C / H	PT560
		4 OSR > 1.375" Brg O.D./4.182" Stack-up	L-1	B / C / H	PT588
SILVERADO 3500 1 TON PICKUP 2WD					
01-06	All Models	4 OSR > 1.188" Brg O.D./4.182" Stack-up	B-1	A / B / C	PT560
		4 OSR > 1.375" Brg O.D./4.182" Stack-up	B-1	A / B / C	PT588
SILVERADO 3500 1 TON PICKUP 4WD					
01-06	All Models	4 ISR > 1.125" Brg O.D./2.555 Stack-up	L-1	A / D	PT3105
		4 OSR > 1.188" Brg O.D./4.182" Stack-up	L-1	B / C / H	PT560
		4 OSR > 1.375" Brg O.D./4.182" Stack-up	L-1	B / C / H	PT588
SSR					
03-06	All Models	4 ISR > 1.125" Brg O.D./2.555 Stack-up	A-1	A / B	PT3105
SUBURBAN 1500 1/2 TON 2WD					
00-06	All Models	4 OSR > 1.063" Brg O.D./3.622" Stack-up	A-1	A	PT530
		2 ISR & 2 OSR > 1.063"/1.125" Brg O.D./2.555" ISR	A-1	B	PT3188
SUBURBAN 1500 1/2 TON 4WD					
01-06	All Models	4 ISR > 1.125" Brg O.D./2.555 Stack-up	L-1	A / B / C / D	PT3105
2000	All Models	4 ISR > 1.125" Brg O.D./2.555 Stack-up	L-1	A / D	PT3105
		4 OSR > 1.188" Brg O.D./3.622" Stack-up	L-1	B / C	PT578
SUBURBAN 2500 3/4 TON 2WD					
01-06	All Models-6.0L	4 OSR > 1.188" Brg O.D./3.622" Stack-up	A-1	A / B	PT578
	All Models-8.1L	4 OSR > 1.188" Brg O.D./4.182" Stack-up	B-1	A / B / C	PT560
2000	All Models	4 OSR > 1.188" Brg O.D./3.622" Stack-up	A-1	A / B	PT578
SUBURBAN 2500 3/4 TON 4WD					
00-06	All Models	4 ISR > 1.125" Brg O.D./2.555 Stack-up	L-1	A / D	PT3105
	All Models-6.0L	4 OSR > 1.188" Brg O.D./3.622" Stack-up	L-1	B / C	PT578
	All Models-8.1L	4 OSR > 1.188" Brg O.D./4.182" Stack-up	L-1	B / C	PT560

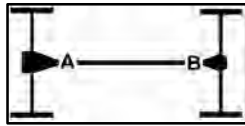

APPLICATION A-1

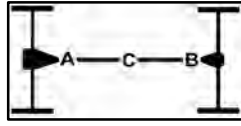

APPLICATION B-1

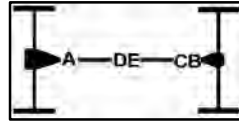

APPLICATION C-1

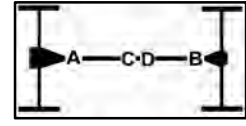

APPLICATION D-1

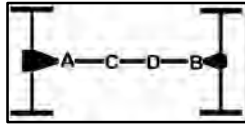

APPLICATION E-1

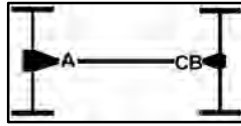

APPLICATION F-1

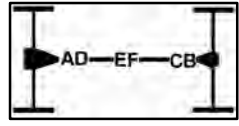

APPLICATION H-1

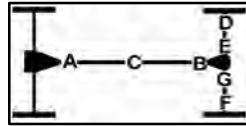

APPLICATION I-1

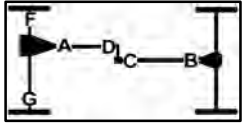

APPLICATION K-1

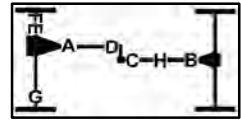

APPLICATION L-1

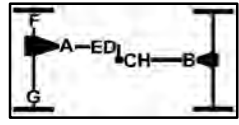

APPLICATION N-1



APPLICATION O-1

MAKE/YEARS FITMENT U-JOINT DESCRIPTION LOCATION POSITION PART NO.

CHEVROLET

CHEVROLET

MAKE/YEARS	FITMENT	U-JOINT DESCRIPTION	LOCATION	POSITION	PART NO.
TAHOE 2WD					
95-06	All Models	4 ISR > 1.125" Brg O.D./2.555 Stack-up	A-1	A / B	PT3105
TAHOE 4WD					
95-06	All Models	4 ISR > 1.125" Brg O.D./2.555 Stack-up	L-1	A / B / C / D	PT3105
TRACKER 2WD					
98-04	All Models	4 OSR > .985" Brg O.D./2.498" Stack-up	A-1	A / B	PT1601
TRACKER 4WD					
98-04	All Models	4 OSR > .985" Brg O.D./2.498" Stack-up	L-1	A / B / C / D	PT1601
TRAILBLAZER 2WD					
02-06	All Models	4 ISR > 1.125" Brg O.D./2.555 Stack-up	A-1	A / B	PT3105
TRAILBLAZER 4WD					
02-06	All Models	2 ISR & 2 OSR > 1.063" Brg O.D/ 3.217" OSR - 2.344" ISR Stack-up	L-1	A	PT445
		4 ISR > 1.125" Brg O.D./2.555 Stack-up	L-1	B / C	PT3105
V10 1/2 TON PICKUP 4WD					
1987	All Models	4 OSR > 1.063" Brg O.D/ 3.217" Stack-up	N-1	A	PT521HD
		4 ISR > 1.125" Brg O.D./2.555 Stack-up	N-1	B / C / D / E	PT3105
		4 OSR > 1.188" Brg O.D./3.622" Stack-up	N-1	B / C	PT578
		4 ISR > 1.188" Brg O.D./2.187" Stack-up	N-1	F / G	PT297
V20 3/4 TON PICKUP 4WD					
1987	All Models	4 OSR > 1.063" Brg O.D/ 3.217" Stack-up	N-1	A	PT521HD
		4 ISR > 1.125" Brg O.D./2.555 Stack-up	N-1	D / E	PT3105
		4 OSR > 1.188" Brg O.D./3.622" Stack-up	N-1	B / C	PT578
		4 ISR > 1.188" Brg O.D./2.187" Stack-up	N-1	F / G	PT297
V30 1 TON PICKUP 4WD					
1988	All Models - 2 Door	4 ISR > 1.125" Brg O.D./2.555 Stack-up	N-1	A / D	PT3105
		4 OSR > 1.063" Brg O.D/ 3.622" Stack-up	N-1	D	PT530
		4 OSR > 1.188" Brg O.D./3.622" Stack-up	N-1	C / B / H	PT578
		2 ISR & 2 OSR > 1.063"/1.125" Brg O.D/ 2.555" ISR	N-1	A	PT3188
	All Models - 4 Door	4 ISR > 1.125" Brg O.D./2.555 Stack-up	N-1	D / E	PT3105
		4 OSR > 1.063" Brg O.D/ 3.217" Stack-up	N-1	A	PT521HD
		4 OSR > 1.188" Brg O.D./3.622" Stack-up	N-1	C / B / H	PT578
	All Models	4 ISR > 1.375" Brg O.D./2.995" Stack-up	N-1	F / G	PT332

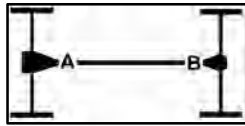

APPLICATION A-1

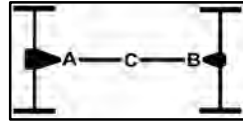

APPLICATION B-1

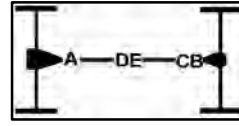

APPLICATION C-1

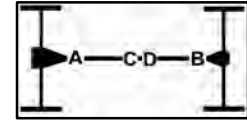

APPLICATION D-1

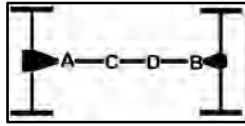

APPLICATION E-1

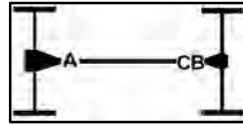

APPLICATION F-1

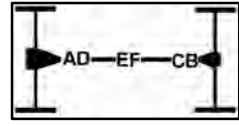

APPLICATION H-1

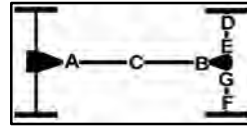

APPLICATION I-1

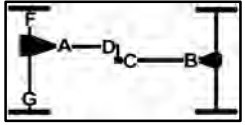

APPLICATION K-1

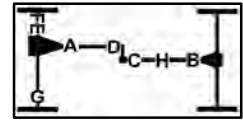

APPLICATION L-1

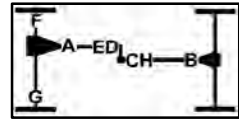

APPLICATION N-1

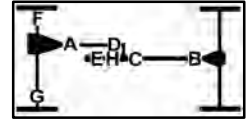

APPLICATION O-1

MAKE/YEARS FITMENT U-JOINT DESCRIPTION LOCATION POSITION PART NO.

CHEVROLET

CHEVROLET

MAKE/YEARS	FITMENT	U-JOINT DESCRIPTION	LOCATION	POSITION	PART NO.
V30 1 TON PICKUP 4WD					
1987	All Models	4 OSR > 1.063" Brg O.D./ 3.217" Stack-up	N-1	C	PT521HD
		4 OSR > 1.188" Brg O.D./3.622" Stack-up	N-1	C / B / H	PT578
		4 ISR > 1.125" Brg O.D./2.555 Stack-up	N-1	D / E	PT3105
		4 ISR > 1.375" Brg O.D./2.995" Stack-up	N-1	F / G	PT332
V3500 1 TON PICKUP 4WD					
89-91	All Models - 2 Door	4 ISR > 1.125" Brg O.D./2.555 Stack-up	N-1	A / D	PT3105
		4 OSR > 1.063" Brg O.D./ 3.622" Stack-up	N-1	D	PT530
		4 OSR > 1.188" Brg O.D./3.622" Stack-up	N-1	C / B / H	PT578
		2 ISR & 2 OSR > 1.063"/1.125" Brg O.D/ 2.555" ISR	N-1	A	PT3188
	All Models - 4 Door	4 ISR > 1.125" Brg O.D./2.555 Stack-up	N-1	D / E	PT3105
		4 OSR > 1.063" Brg O.D./ 3.217" Stack-up	N-1	A	PT521HD
		4 OSR > 1.188" Brg O.D./3.622" Stack-up	N-1	C / B / H	PT578
	All Models	4 ISR > 1.375" Brg O.D./2.995" Stack-up	N-1	F / G	PT332
VEGA					
71-81	All Models	4 OSR > 1.063" Brg O.D./ 3.217" Stack-up	A-1	A / B	PT521HD

CHRYSLER

CHRYSLER

MAKE/YEARS	FITMENT	U-JOINT DESCRIPTION	LOCATION	POSITION	PART NO.
CONQUEST					
87-89	All Models	4 OSR > .985" Brg O.D./3.030" Stack-up	A-1	A / B	PT1625
CORDOBA					
75-83	All Models	4 ISR > 1.078" Brg O.D./2.121" Stack-up	A-1	A / B	PT266
		4 ISR > 1.125" Brg O.D./2.619" Stack-up	A-1	A / B	PT231
FIFTH AVENUE					
86-89	All Models	4 ISR > 1.078" Brg O.D./2.121" Stack-up	A-1	A / B	PT266
1983	All Models	4 ISR > 1.078" Brg O.D./2.121" Stack-up	A-1	A / B	PT266
IMPERIAL					
81-83	All Models	4 ISR > 1.078" Brg O.D./2.121" Stack-up	A-1	A / B	PT266
70-75	All Models	4 ISR > 1.125" Brg O.D./2.619" Stack-up	A-1	A / B	PT231
		4 OSR > 1.063" Brg O.D./ 3.622" Stack-up	A-1	A / B	PT530

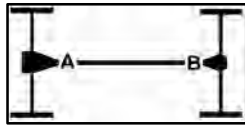

APPLICATION A-1

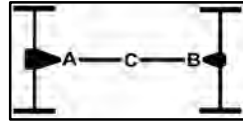

APPLICATION B-1

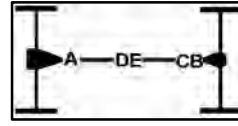

APPLICATION C-1

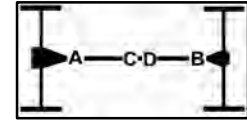

APPLICATION D-1

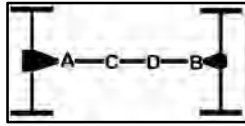

APPLICATION E-1

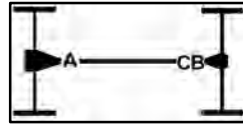

APPLICATION F-1

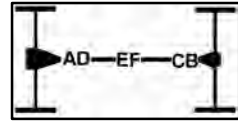

APPLICATION H-1

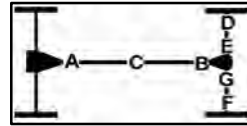

APPLICATION I-1

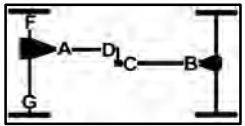

APPLICATION K-1

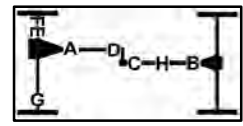

APPLICATION L-1

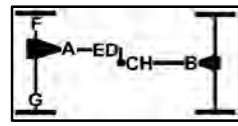

APPLICATION N-1



APPLICATION O-1

MAKE/YEARS FITMENT U-JOINT DESCRIPTION LOCATION POSITION PART NO.

CHRYSLER**CHRYSLER**

LEBARON					
77-90	All Models	4 ISR > 1.078" Brg O.D./2.121" Stack-up	A-1	A / B	PT266
		4 ISR > 1.125" Brg O.D./2.619" Stack-up	A-1	A / B	PT231
NEW YORKER					
70-86	All Models	4 ISR > 1.078" Brg O.D./2.121" Stack-up	A-1	A / B	PT266
		4 ISR > 1.125" Brg O.D./2.619" Stack-up	A-1	A / B	PT231
NEWPORT					
70-81	All Models	4 ISR > 1.078" Brg O.D./2.121" Stack-up	A-1	A / B	PT266
		4 ISR > 1.125" Brg O.D./2.619" Stack-up	A-1	A / B	PT231

DODGE**DODGE**

ASPEN					
76-80	All Models	4 ISR > 1.078" Brg O.D./2.121" Stack-up	A-1	A / B	PT266
		4 ISR > 1.125" Brg O.D./2.619" Stack-up	A-1	A / B	PT231
B100 1/2 TON VAN 2WD					
70-80	All Models	4 ISR > 1.078" Brg O.D./2.121" Stack-up	A-1	A / B	PT266
		4 ISR > 1.125" Brg O.D./2.619" Stack-up	A-1	A / B	PT231
B150 1/2 TON VAN 2WD					
81-93	All Models	4 ISR > 1.078" Brg O.D./2.121" Stack-up	A-1	A / B	PT266
		4 ISR > 1.125" Brg O.D./2.619" Stack-up	A-1	A / B	PT231
B200 3/4 TON VAN 2WD					
70-80	All Models	4 ISR > 1.078" Brg O.D./2.121" Stack-up	A-1	A / B	PT266
		4 ISR > 1.125" Brg O.D./2.619" Stack-up	A-1	A / B	PT231
B250 3/4 TON VAN 2WD					
81-93	All Models	4 ISR > 1.078" Brg O.D./2.121" Stack-up	A-1	A / B	PT266
		4 ISR > 1.125" Brg O.D./2.619" Stack-up	A-1	A / B	PT231
B300 1 TON VAN 2WD					
70-80	All Models	4 ISR > 1.078" Brg O.D./2.121" Stack-up	B-1	A / B / C	PT266
		4 ISR > 1.125" Brg O.D./2.619" Stack-up	B-1	A / B / C	PT231
B350 1 TON VAN 2WD					
81-93	All Models - 2 or 3 Joint Driveshaft	4 ISR > 1.078" Brg O.D./2.121" Stack-up	B-1	A / B / C	PT266
		4 ISR > 1.125" Brg O.D./2.619" Stack-up	B-1	A / B / C	PT231

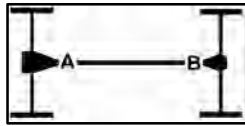

APPLICATION A-1

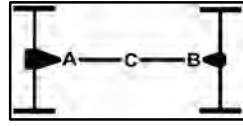

APPLICATION B-1

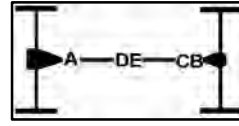

APPLICATION C-1

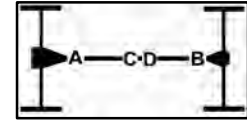

APPLICATION D-1

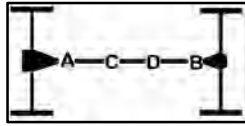

APPLICATION E-1

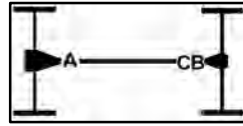

APPLICATION F-1

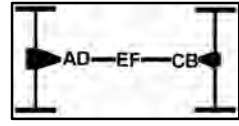

APPLICATION H-1

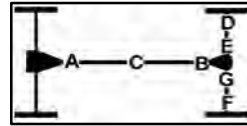

APPLICATION I-1

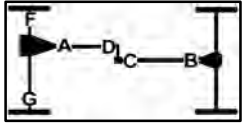

APPLICATION K-1

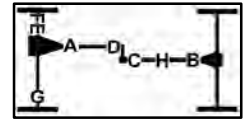

APPLICATION L-1

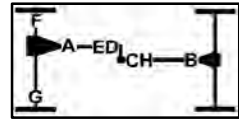

APPLICATION N-1

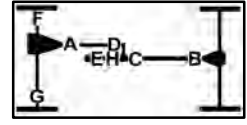

APPLICATION O-1

MAKE/YEARS FITMENT U-JOINT DESCRIPTION LOCATION POSITION PART NO.

DODGE

DODGE

MAKE/YEARS	FITMENT	U-JOINT DESCRIPTION	LOCATION	POSITION	PART NO.
B1500 1/2 TON VAN 2WD					
02-03	All Models	4 OSR > 1.063" Brg O.D/ 3.622" Stack-up	A-1	A / B	PT530
94-01	All Models	4 OSR > 1.063" Brg O.D/ 3.622" Stack-up	A-1	A / B	PT530
		2 ISR & 2 OSR > 1.063"-1.125" Brg O.D/ 3.622" OSR - 2.625" ISR Stack-up	A-1	B	PT362
		4 OSR > 1.188" Brg O.D./4.182" Stack-up	A-1	A / B	PT560
		4 ISR > 1.125" Brg O.D./2.619" Stack-up	A-1	A / B	PT231
B2500 3/4 TON VAN 2WD					
02-03	All Models	4 OSR > 1.063" Brg O.D/ 3.622" Stack-up	A-1	A / B	PT530
94-01	All Models	4 OSR > 1.063" Brg O.D/ 3.622" Stack-up	A-1	A / B	PT530
		2 ISR & 2 OSR > 1.063"-1.125" Brg O.D/ 3.622" OSR - 2.625" ISR Stack-up	A-1	B	PT362
		4 OSR > 1.188" Brg O.D./4.182" Stack-up	A-1	A / B	PT560
		4 ISR > 1.125" Brg O.D./2.619" Stack-up	A-1	A / B	PT231
B350 1 TON VAN 2WD					
02-03	All Models	4 OSR > 1.188" Brg O.D./4.182" Stack-up	A-1	A / B	PT560
94-01	All Models	4 OSR > 1.063" Brg O.D/ 3.622" Stack-up	A-1	A / B	PT530
		2 ISR & 2 OSR > 1.063"-1.125" Brg O.D/ 3.622" OSR - 2.625" ISR Stack-up	A-1	B	PT362
		4 OSR > 1.188" Brg O.D./4.182" Stack-up	A-1	A / B	PT560
		4 ISR > 1.125" Brg O.D./2.619" Stack-up	A-1	A / B	PT231
CHALLENGER					
81-83	All Models-Manual Transmission	4 OSR > .985" Brg O.D./3.030" Stack-up	B-1	A / B / C	PT1625
	All Models-Automatic Transmission	4 OSR > .985" Brg O.D./2.498" Stack-up	B-1	A / B / C	PT1601
78-80	All Models	4 OSR > .985" Brg O.D./3.030" Stack-up	A-1	A / B	PT1625
73-74	All Models	4 ISR > 1.078" Brg O.D./2.121" Stack-up	A-1	A / B	PT266
70-72	All Models	4 ISR > 1.078" Brg O.D./2.121" Stack-up	A-1	A / B	PT266
		4 ISR > 1.125" Brg O.D./2.619" Stack-up	A-1	A / B	PT231
CHARGER					
70-78	All Models	4 ISR > 1.078" Brg O.D./2.121" Stack-up	A-1	A / B	PT266
		4 ISR > 1.125" Brg O.D./2.619" Stack-up	A-1	A / B	PT231

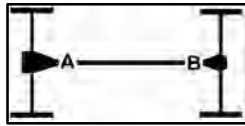

APPLICATION A-1

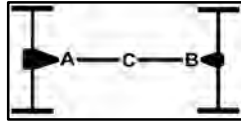

APPLICATION B-1

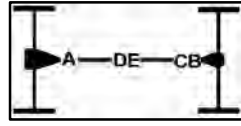

APPLICATION C-1

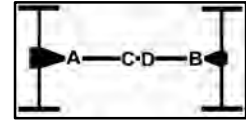

APPLICATION D-1

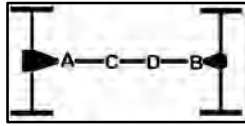

APPLICATION E-1

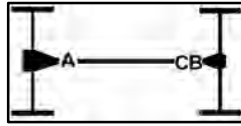

APPLICATION F-1

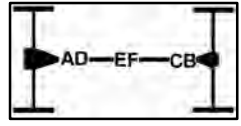

APPLICATION H-1

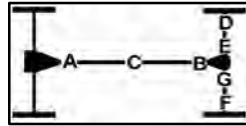

APPLICATION I-1

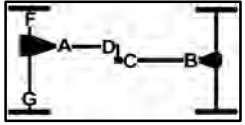

APPLICATION K-1

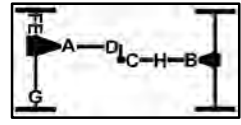

APPLICATION L-1

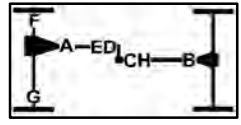

APPLICATION N-1



APPLICATION O-1

MAKE/YEARS FITMENT U-JOINT DESCRIPTION LOCATION POSITION PART NO.

DODGE

DODGE

MAKE/YEARS	FITMENT	U-JOINT DESCRIPTION	LOCATION	POSITION	PART NO.
COLT RWD					
71-80	All Models	4 OSR >.985" Brg O.D./3.030" Stack-up	A-1	A / B	PT1625
		4 ISR >.985" Brg O.D./2.498" Stack-up	A-1	A / B	PT1601
COLT VISTA AWD					
84-91	All Models	4 ISR >.985" Brg O.D./2.498" Stack-up	A-1	A / B	PT1601
CONQUEST					
84-86	All Models	4 OSR >.985" Brg O.D./3.030" Stack-up	A-1	A / B	PT1625
CORONET					
70-76	All Models	4 ISR > 1.078" Brg O.D./2.121" Stack-up	A-1	A / B	PT266
		4 ISR > 1.125" Brg O.D./2.619" Stack-up	A-1	A / B	PT231
D50 2WD					
79-82	All Models - 2.0L	4 ISR >.985" Brg O.D./2.498" Stack-up	A-1	A / B	PT1601
	All Models - 2.6L	4 OSR >.985" Brg O.D./3.030" Stack-up	A-1	A / B	PT1625
D100 1/2 TON PICKUP 2WD					
70-79	All Models-2 or 3 Joint Driveshaft	4 ISR > 1.078" Brg O.D./2.121" Stack-up	B-1	A / B / C	PT266
		4 ISR > 1.125" Brg O.D./2.619" Stack-up	B-1	A / B / C	PT231
D150 1/2 TON PICKUP 2WD					
77-93	All Models-2 or 3 Joint Driveshaft	4 ISR > 1.078" Brg O.D./2.121" Stack-up	B-1	A / B / C	PT266
		4 ISR > 1.125" Brg O.D./2.619" Stack-up	B-1	A / B / C	PT231
D200 3/4 TON PICKUP 2WD					
70-80	All Models-2 or 3 Joint Driveshaft	4 ISR > 1.078" Brg O.D./2.121" Stack-up	B-1	A / B / C	PT266
		4 ISR > 1.125" Brg O.D./2.619" Stack-up	B-1	A / B / C	PT231
D250 3/4 TON PICKUP 2WD					
89-93	All Models - 5.9L Dsl - 2 or 3 Joint Driveshaft	4 OSR > 1.188" Brg O.D./4.182" Stack-up	B-1	A / B / C	PT560
	All Models - Exc. 5.9L Dsl - 2 or 3 Joint Driveshaft	4 ISR > 1.078" Brg O.D./2.121" Stack-up	B-1	A / B / C	PT266
81-88	All Models-2 or 3 Joint Driveshaft	4 ISR > 1.078" Brg O.D./2.121" Stack-up	B-1	A / B / C	PT266
		4 ISR > 1.125" Brg O.D./2.619" Stack-up	B-1	A / B / C	PT231
D300 1 TON PICKUP 2WD					
70-80	All Models-2 or 3 Joint Driveshaft	4 ISR > 1.078" Brg O.D./2.121" Stack-up	B-1	A / B / C	PT266
		4 ISR > 1.125" Brg O.D./2.619" Stack-up	B-1	A / B / C	PT231

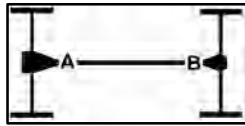

APPLICATION A-1

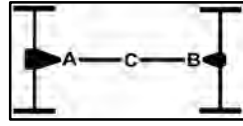

APPLICATION B-1

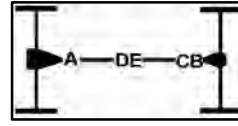

APPLICATION C-1

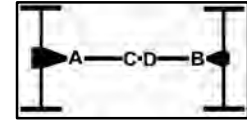

APPLICATION D-1

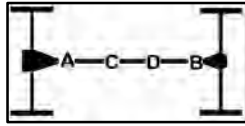

APPLICATION E-1

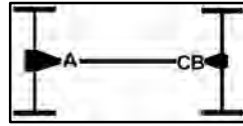

APPLICATION F-1

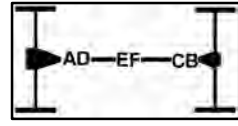

APPLICATION H-1

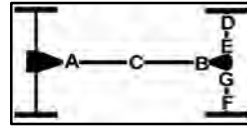

APPLICATION I-1

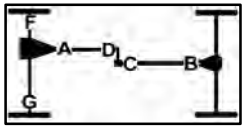

APPLICATION K-1

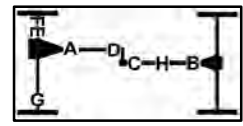

APPLICATION L-1

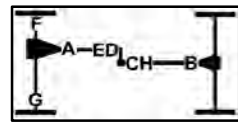

APPLICATION N-1



APPLICATION O-1

MAKE/YEARS FITMENT U-JOINT DESCRIPTION LOCATION POSITION PART NO.

DODGE**DODGE****D350 1 TON PICKUP 2WD**

89-93 All Models - 5.9L Dsl - 2 or 3 Joint Driveshaft	4 OSR > 1.188" Brg O.D./4.182" Stack-up	B-1	A / B / C	PT560
All Models - Exc. 5.9L Dsl - 2 or 3 Joint Driveshaft	4 ISR > 1.078" Brg O.D./2.121" Stack-up	B-1	A / B / C	PT266
81-88 All Models-2 or 3 Joint Driveshaft	4 ISR > 1.078" Brg O.D./2.121" Stack-up	B-1	A / B / C	PT266
	4 ISR > 1.125" Brg O.D./2.619" Stack-up	B-1	A / B / C	PT231

DAKOTA 2WD

00-06 All Models-2 or 3 Joint Driveshaft	4 OSR > 1.063" Brg O.D/ 3.622" Stack-up	B-1	A / B / C	PT530
1999 All Models-2 or 3 Joint Driveshaft	4 OSR > 1.063" Brg O.D/ 3.622" Stack-up	B-1	A / B / C	PT530
	2 ISR & 2 OSR > 1.063"-1.125" Brg O.D/ 3.622" OSR - 2.625" ISR Stack-up	B-1	B / C	PT362
87-98 All Models	4 ISR > 1.078" Brg O.D./2.121" Stack-up	B-1	A / B / C	PT266
	4 ISR > 1.125" Brg O.D./2.619" Stack-up	B-1	A / B / C	PT231

DAKOTA 4WD

00-06 All Models-2 or 3 Joint Driveshaft	4 OSR > 1.063" Brg O.D/ 3.622" Stack-up	B-1	A / B / C	PT530
1999 All Models-2 or 3 Joint Driveshaft	4 OSR > 1.063" Brg O.D/ 3.622" Stack-up	B-1	A / B / C	PT530
	2 ISR & 2 OSR > 1.063"-1.125" Brg O.D/ 3.622" OSR - 2.625" ISR Stack-up	B-1	B / C	PT362
87-98 All Models - 2 or 3 Joint Driveshaft	4 ISR > 1.078" Brg O.D./2.121" Stack-up	B-1	A / B / C	PT266
	4 ISR > 1.125" Brg O.D./2.619" Stack-up	A-1	A / B	PT231

DIPLOMAT

77-89 All Models	4 ISR > 1.078" Brg O.D./2.121" Stack-up	A-1	A / B	PT266
-------------------------	---	-----	-------	-------

DURANGO 2WD

04-06 All Models	4 ISR > 1.125" Brg O.D./2.555 Stack-up	A-1	A / B	PT3105
00-03 All Models	4 OSR > 1.063" Brg O.D/ 3.622" Stack-up	A-1	A / B	PT530

DURANGO 4WD

04-06 All Models	4 OSR > 1.063" Brg O.D/ 3.217" Stack-up	N-1	A	PT521HD
	4 ISR > 1.125" Brg O.D./2.555 Stack-up	N-1	B / C	PT3105
00-03 All Models	4 OSR > 1.063" Brg O.D/ 3.217" Stack-up	N-1	A / D / E	PT521HD
	4 OSR > 1.063" Brg O.D/ 3.622" Stack-up	N-1	B / C	PT530

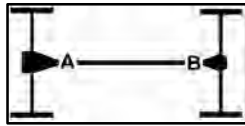

APPLICATION A-1

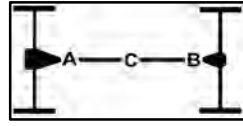

APPLICATION B-1

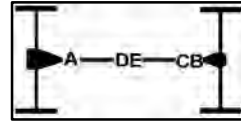

APPLICATION C-1

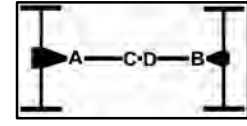

APPLICATION D-1

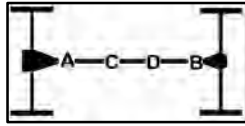

APPLICATION E-1

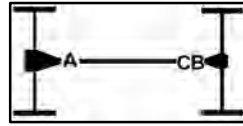

APPLICATION F-1

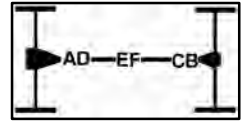

APPLICATION H-1

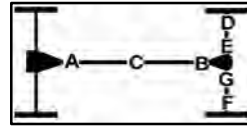

APPLICATION I-1

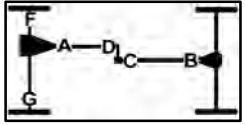

APPLICATION K-1

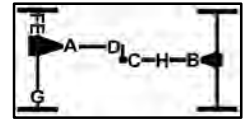

APPLICATION L-1

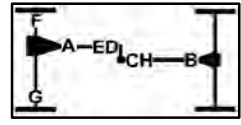

APPLICATION N-1

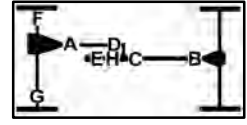

APPLICATION O-1

MAKE/YEARS FITMENT U-JOINT DESCRIPTION LOCATION POSITION PART NO.

DODGE

DODGE

MAKE/YEARS	FITMENT	U-JOINT DESCRIPTION	LOCATION	POSITION	PART NO.
DURANGO 4WD					
1999	All Models	4 OSR > 1.063" Brg O.D/ 3.217" Stack-up	N-1	A / D	PT521HD
		2 ISR & 2 OSR > 1.063"-1.125" Brg O.D/ 3.622" OSR - 2.625" ISR Stack-up	N-1	B	PT362
		4 OSR > 1.063" Brg O.D/ 3.622" Stack-up	N-1	C	PT530
1998	All Models	4 OSR > 1.063" Brg O.D/ 3.217" Stack-up	N-1	A / D	PT521HD
		4 ISR > 1.125" Brg O.D./2.619" Stack-up	N-1	B / C	PT231
MIRADA					
80-83	All Models	4 ISR > 1.078" Brg O.D./2.121" Stack-up	A-1	A / B	PT266
MONACO					
70-78	All Models	4 ISR > 1.078" Brg O.D./2.121" Stack-up	A-1	A / B	PT266
		4 ISR > 1.125" Brg O.D./2.619" Stack-up	A-1	A / B	PT231
POLARA					
70-73	All Models	4 ISR > 1.078" Brg O.D./2.121" Stack-up	A-1	A / B	PT266
		4 ISR > 1.125" Brg O.D./2.619" Stack-up	A-1	A / B	PT231
RAMCHARGER 2WD					
74-93	All Models	4 ISR > 1.078" Brg O.D./2.121" Stack-up	A-1	A / B	PT266
		4 ISR > 1.125" Brg O.D./2.619" Stack-up	A-1	A / B	PT231
RAMCHARGER 4WD					
78-93	All Models	4 ISR > 1.125" Brg O.D./2.555 Stack-up	N-1	D / E	PT3105
		4 ISR > 1.078" Brg O.D./2.121" Stack-up	N-1	A / B / C	PT266
		4 ISR > 1.125" Brg O.D./2.619" Stack-up	N-1	B / C	PT231
		4 ISR > 1.188" Brg O.D./2.187" Stack-up	N-1	F / G	PT297
74-77	All Models	4 ISR > 1.125" Brg O.D./2.555 Stack-up	N-1	D / E	PT3105
		4 OSR > 1.063" Brg O.D/ 3.217" Stack-up	N-1	A / D / E	PT521HD
		4 ISR > 1.078" Brg O.D./2.121" Stack-up	N-1	A / B / C	PT266
		4 ISR > 1.125" Brg O.D./2.619" Stack-up	N-1	B	PT231
		4 ISR > 1.188" Brg O.D./2.187" Stack-up	N-1	F / G	PT297
RAM 50					
89-93	All Models - 2 or 3 Joint Driveshaft	4 ISR > .985" Brg O.D./2.498" Stack-up	B-1	A / B / C	PT1601
		4 OSR > .985" Brg O.D./3.030" Stack-up	B-1	A / B / C	PT1625
86-88	All Models - 2.0L	4 ISR > .985" Brg O.D./2.498" Stack-up	A-1	A / B	PT1601
	All Models - 2.6L	4 OSR > .985" Brg O.D./3.030" Stack-up	A-1	A / B	PT1625

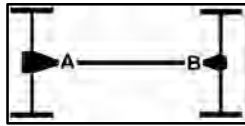

APPLICATION A-1

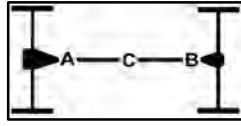

APPLICATION B-1

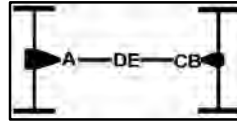

APPLICATION C-1

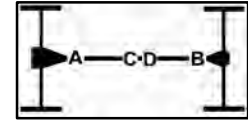

APPLICATION D-1

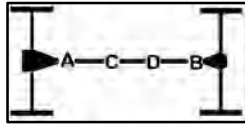

APPLICATION E-1

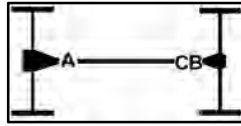

APPLICATION F-1

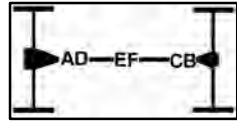

APPLICATION H-1

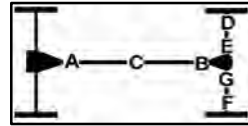

APPLICATION I-1

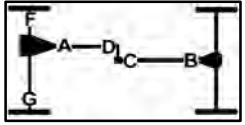

APPLICATION K-1

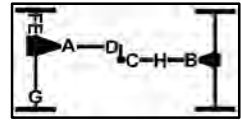

APPLICATION L-1

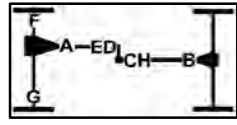

APPLICATION N-1



APPLICATION O-1

MAKE/YEARS FITMENT U-JOINT DESCRIPTION LOCATION POSITION PART NO.

DODGE

DODGE

MAKE/YEARS	FITMENT	U-JOINT DESCRIPTION	LOCATION	POSITION	PART NO.
RAM 50					
83-85	All Models - 2.0L	4 ISR > .985" Brg O.D./2.498" Stack-up	A-1	A / B	PT1601
	All Models - 2.6L & 2.3L Dsl	4 OSR > .985" Brg O.D./3.030" Stack-up	A-1	A / B	PT1625
1982	All Models - 2.0L	4 ISR > .985" Brg O.D./2.498" Stack-up	A-1	A / B	PT1601
	All Models - 2.6L	4 OSR > .985" Brg O.D./3.030" Stack-up	A-1	A / B	PT1625
RAM 1500 1/2 TON PICKUP 2WD					
04-06	All Models - 2 or 3 Joint Driveshaft - Exc. SRT, Exc. Hemi	4 OSR > 1.063" Brg O.D./ 3.622" Stack-up	B-1	A / B / C	PT530
	All Models - HEMI - 2 Joint Driveshaft	4 OSR > 1.063" Brg O.D./ 3.622" Stack-up	A-1	A / B	PT530
	All Models - HEMI - 3 Joint Driveshaft	4 OSR > 1.188" Brg O.D./3.622" Stack-up	B-1	A / B / C	PT578
	All Models - SRT	4 OSR > 1.188" Brg O.D./3.622" Stack-up	B-1	A / B	PT578
		4 OSR > 1.188" Brg O.D./4.182" Stack-up	B-1	A / B / C	PT560
00-03	All Models - 2 or 3 Joint Driveshaft	4 OSR > 1.063" Brg O.D/ 3.622" Stack-up	B-1	A / B / C	PT530
94-99	All Models - 2 or 3 Joint Driveshaft	4 ISR > 1.125" Brg O.D./2.619" Stack-up	B-1	A / B / C	PT231
		2 ISR & 2 OSR > 1.063"-1.125" Brg O.D/ 3.622" OSR - 2.625" ISR Stack-up	B-1	A / B	PT362
RAM 1500 1/2 TON PICKUP 4WD					
02-06	All Models	4 OSR > 1.063" Brg O.D/ 3.622" Stack-up	N-1	A / D / E	PT530
		4 OSR > 1.063" Brg O.D/ 3.622" Stack-up	N-1	B / C / H	PT530
00-01	All Models	4 OSR > 1.063" Brg O.D/ 3.622" Stack-up	N-1	A / D / E	PT530
		4 OSR > 1.063" Brg O.D/ 3.622" Stack-up	N-1	B / C / H	PT530
		4 ISR > 1.188" Brg O.D./2.187" Stack-up	N-1	F / G	PT297
1999	All Models	4 OSR > 1.063" Brg O.D/ 3.622" Stack-up	N-1	B / C / D / E	PT530
		2 ISR & 2 OSR > 1.063"-1.125" Brg O.D/ 3.622" OSR - 2.625" ISR Stack-up	N-1	A / B	PT362
		4 ISR > 1.188" Brg O.D./2.187" Stack-up	N-1	F / G	PT297
1998	All Models	4 OSR > 1.063" Brg O.D/ 3.622" Stack-up	N-1	D / E	PT530
		2 ISR & 2 OSR > 1.063"-1.125" Brg O.D/ 3.622" OSR - 2.625" ISR Stack-up	N-1	A	PT362
		4 ISR > 1.125" Brg O.D./2.619" Stack-up	N-1	A / B / C / H	PT231
		4 ISR > 1.188" Brg O.D./2.187" Stack-up	N-1	F / G	PT297

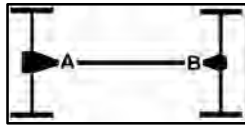

APPLICATION A-1

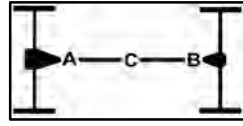

APPLICATION B-1

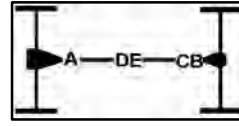

APPLICATION C-1

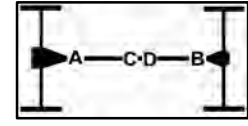

APPLICATION D-1

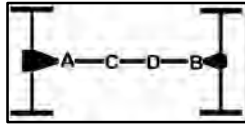

APPLICATION E-1

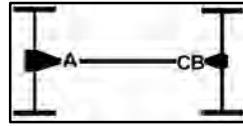

APPLICATION F-1

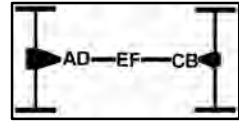

APPLICATION H-1

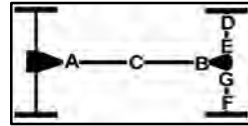

APPLICATION I-1

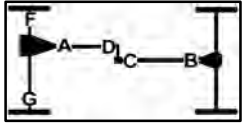

APPLICATION K-1

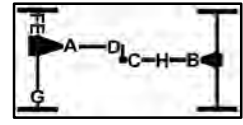

APPLICATION L-1

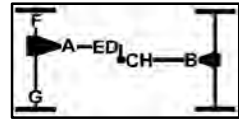

APPLICATION N-1



APPLICATION O-1

MAKE/YEARS FITMENT U-JOINT DESCRIPTION LOCATION POSITION PART NO.

DODGE

DODGE

MAKE/YEARS	FITMENT	U-JOINT DESCRIPTION	LOCATION	POSITION	PART NO.
RAM 1500 1/2 TON PICKUP 4WD					
94-97	All Models	4 OSR > 1.063" Brg O.D./ 3.622" Stack-up	N-1	D / E	PT530
		4 ISR > 1.125" Brg O.D./2.619" Stack-up	N-1	A / B / C / H	PT231
		4 ISR > 1.188" Brg O.D./2.187" Stack-up	N-1	F / G	PT297
RAM 2500 3/4 TON PICKUP 2WD					
04-06	All Models - 2 or 3 Joint Driveshaft - Exc. 5.9L Dsl M/T	4 OSR > 1.188" Brg O.D./4.182" Stack-up	B-1	A / B / C	PT560
	All Models - 5.9L Dsl M/T	4 OSR > 1.375" Brg O.D./4.178" Stack-up	B-1	A / B / C	PT587
		4 OSR > 1.375" Brg O.D./4.182" Stack-up	B-1	A / B / C	PT588
99-03	All Models - 2 or 3 Joint Driveshaft	4 OSR > 1.188" Brg O.D./4.182" Stack-up	B-1	A / B / C	PT560
		4 OSR > 1.375" Brg O.D./4.178" Stack-up	B-1	A / B / C	PT587
97-98	All Models - 2 or 3 Joint Driveshaft	4 OSR > 1.188" Brg O.D./4.182" Stack-up	B-1	A / B / C	PT560
		2 ISR & 2 OSR > 1.063"-1.125" Brg O.D./ 3.622" OSR - 2.625" ISR Stack-up	B-1	A / B	PT362
94-96	All Models - 5.2L & 5.9L V8 - 2 or 3 Joint Driveshaft	4 ISR > 1.125" Brg O.D./2.619" Stack-up	B-1	A / B / C	PT231
	All Models - 8.0L V10 & 5.9L Dsl - 2 or 3 Joint Driveshaft	4 OSR > 1.188" Brg O.D./4.182" Stack-up	B-1	A / B / C	PT560
RAM 2500 3/4 TON PICKUP 4WD					
05-06	All Models	4 OSR > 1.063" Brg O.D./ 3.622" Stack-up	N-1	D / E	PT530
		4 OSR > 1.188" Brg O.D./3.622" Stack-up	N-1	D / E	PT578
		4 ISR > 1.125" Brg O.D./2.555 Stack-up	N-1	A	PT3105
		4 OSR > 1.188" Brg O.D./4.182" Stack-up	N-1	B / C / H	PT560
		4 OSR > 1.375" Brg O.D./4.182" Stack-up	N-1	B / C / H	PT588
		4 ISR > 1.375" Brg O.D./2.918" Stack-up	N-1	F / G	PT464
03-04	All Models	4 OSR > 1.063" Brg O.D./ 3.622" Stack-up	N-1	D / E	PT530
		4 ISR > 1.125" Brg O.D./2.555 Stack-up	N-1	A	PT3105
		4 OSR > 1.188" Brg O.D./4.182" Stack-up	N-1	B / C / H	PT560
		4 OSR > 1.375" Brg O.D./4.178" Stack-up	N-1	B / C / H	PT587
		4 ISR > 1.375" Brg O.D./2.918" Stack-up	N-1	F / G	PT464
00-02	All Models	4 OSR > 1.063" Brg O.D./ 3.622" Stack-up	N-1	A / D / E	PT530
		4 OSR > 1.188" Brg O.D./4.182" Stack-up	N-1	B / C / H	PT560
		4 ISR > 1.375" Brg O.D./2.995" Stack-up	N-1	F / G	PT332

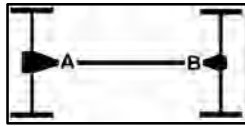

APPLICATION A-1

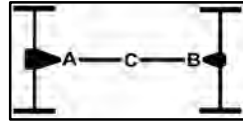

APPLICATION B-1

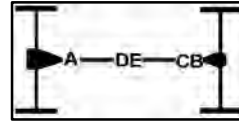

APPLICATION C-1

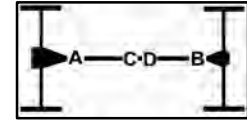

APPLICATION D-1

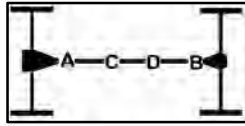

APPLICATION E-1

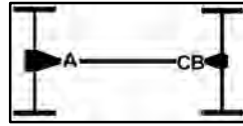

APPLICATION F-1

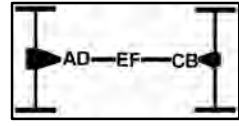

APPLICATION H-1

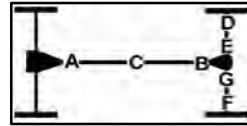

APPLICATION I-1

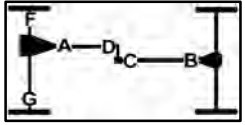

APPLICATION K-1

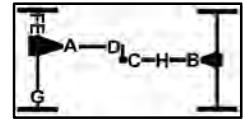

APPLICATION L-1

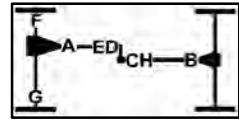

APPLICATION N-1

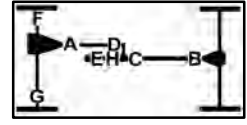

APPLICATION O-1

MAKE/YEARS FITMENT U-JOINT DESCRIPTION LOCATION POSITION PART NO.

DODGE

DODGE

RAM 2500 3/4 TON PICKUP 4WD					
94-99 All Models					
	4 OSR > 1.063" Brg O.D/ 3.622" Stack-up	N-1	D / E	PT530	
	4 ISR > 1.125" Brg O.D./2.619" Stack-up	N-1	A / B / C	PT231	
	2 ISR & 2 OSR > 1.063"-1.125" Brg O.D/ 3.622" OSR - 2.625" ISR Stack-up	N-1	A	PT362	
	4 OSR > 1.188" Brg O.D./4.182" Stack-up	N-1	B / C / H	PT560	
	4 ISR > 1.188" Brg O.D./2.187" Stack-up	N-1	F / G	PT297	
	4 ISR > 1.375" Brg O.D./2.995" Stack-up	N-1	F / G	PT332	
RAM 3500 1 TON PICKUP 2WD					
04-06 All Models - 2 or 3 Joint Driveshaft - Exc. 5.9L Dsl M/T					
	4 OSR > 1.188" Brg O.D./4.182" Stack-up	B-1	A / B / C	PT560	
All Models - 5.9L Dsl M/T					
	4 OSR > 1.375" Brg O.D./4.178" Stack-up	B-1	A / B / C	PT587	
	4 OSR > 1.375" Brg O.D./4.182" Stack-up	B-1	A / B / C	PT588	
97-03 All Models - 2 or 3 Joint Driveshaft					
	4 OSR > 1.188" Brg O.D./4.182" Stack-up	B-1	A / B / C	PT560	
	4 OSR > 1.375" Brg O.D./4.178" Stack-up	B-1	A / B / C	PT587	
94-96 All Models - 5.2L & 5.9L V8 - 2 or 3 Joint Driveshaft					
	4 ISR > 1.078" Brg O.D./2.121" Stack-up	B-1	A / B / C	PT266	
All Models - 8.0L V10 & 5.9L Dsl - 2 or 3 Joint Driveshaft					
	4 OSR > 1.188" Brg O.D./4.182" Stack-up	B-1	A / B / C	PT560	
RAM 3500 1 TON PICKUP 4WD					
05-06 All Models					
	4 OSR > 1.063" Brg O.D/ 3.622" Stack-up	N-1	D / E	PT530	
	4 OSR > 1.188" Brg O.D./3.622" Stack-up	N-1	D / E	PT578	
	4 ISR > 1.125" Brg O.D./2.555 Stack-up	N-1	A	PT3105	
	4 OSR > 1.188" Brg O.D./4.182" Stack-up	N-1	B / C / H	PT560	
	4 OSR > 1.375" Brg O.D./4.182" Stack-up	N-1	B / C / H	PT588	
	4 ISR > 1.375" Brg O.D./2.918" Stack-up	N-1	F / G	PT464	
03-04 All Models					
	4 OSR > 1.063" Brg O.D/ 3.622" Stack-up	N-1	D / E	PT530	
	4 ISR > 1.125" Brg O.D./2.555 Stack-up	N-1	A	PT3105	
	4 OSR > 1.188" Brg O.D./4.182" Stack-up	N-1	B / C / H	PT560	
	4 OSR > 1.375" Brg O.D./4.178" Stack-up	N-1	B / C / H	PT587	
	4 ISR > 1.375" Brg O.D./2.918" Stack-up	N-1	F / G	PT464	
00-02 All Models					
	4 OSR > 1.063" Brg O.D/ 3.622" Stack-up	N-1	A / D / E	PT530	
	4 OSR > 1.188" Brg O.D./4.182" Stack-up	N-1	B / C / H	PT560	
	4 ISR > 1.375" Brg O.D./2.995" Stack-up	N-1	F / G	PT332	

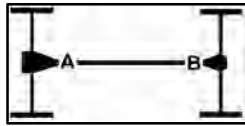

APPLICATION A-1

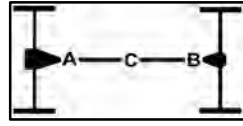

APPLICATION B-1

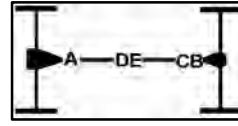

APPLICATION C-1

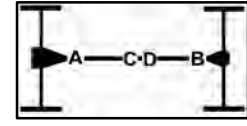

APPLICATION D-1

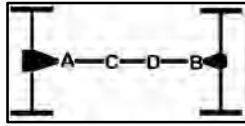

APPLICATION E-1

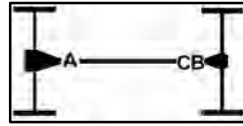

APPLICATION F-1

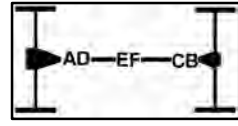

APPLICATION H-1

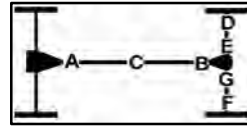

APPLICATION I-1

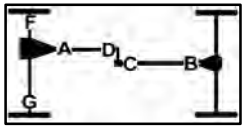

APPLICATION K-1

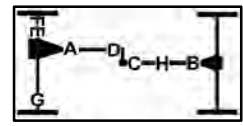

APPLICATION L-1

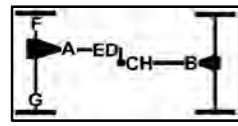

APPLICATION N-1



APPLICATION O-1

MAKE/YEARS FITMENT U-JOINT DESCRIPTION LOCATION POSITION PART NO.

DODGE

DODGE

MAKE/YEARS	FITMENT	U-JOINT DESCRIPTION	LOCATION	POSITION	PART NO.
RAM 3500 1 TON PICKUP 4WD					
94-99 All Models					
		4 OSR > 1.063" Brg O.D./ 3.622" Stack-up	N-1	D / E	PT530
		4 ISR > 1.125" Brg O.D./2.619" Stack-up	N-1	A / B / C	PT231
		2 ISR & 2 OSR > 1.063"-1.125" Brg O.D/ 3.622" OSR - 2.625" ISR Stack-up	N-1	A	PT362
		4 OSR > 1.188" Brg O.D./4.182" Stack-up	N-1	B / C / H	PT560
		4 ISR > 1.375" Brg O.D./2.995" Stack-up	N-1	F / G	PT332
ST. REGIS					
79-81 All Models					
		4 ISR > 1.078" Brg O.D./2.121" Stack-up	A-1	A / B	PT266
VIPER					
92-04 All Models					
		4 OSR > 1.188" Brg O.D./3.622" Stack-up	I-1	A / B	PT578
		4 OSR > 1.188" Brg O.D./3.622" Stack-up	I-1	D / E / F / G	PT578
W100 1/2 TON PICKUP 4WD					
77-79 All Models					
		4 ISR > 1.125" Brg O.D./2.555 Stack-up	N-1	D / E	PT3105
		4 ISR > 1.078" Brg O.D./2.121" Stack-up	N-1	A / B / C / H	PT266
		4 ISR > 1.125" Brg O.D./2.619" Stack-up	N-1	B	PT231
		4 ISR > 1.188" Brg O.D./2.187" Stack-up	N-1	F / G	PT297
75-76 All Models					
		4 ISR > 1.125" Brg O.D./2.555 Stack-up	N-1	D / E	PT3105
		4 OSR > 1.063" Brg O.D./ 3.217" Stack-up	N-1	D / E	PT521HD
		4 ISR > 1.078" Brg O.D./2.121" Stack-up	N-1	A / B / C / H	PT266
		4 ISR > 1.125" Brg O.D./2.619" Stack-up	N-1	B	PT231
		4 ISR > 1.188" Brg O.D./2.187" Stack-up	N-1	F / G	PT297
70-74 All Models					
		4 ISR > 1.078" Brg O.D./2.121" Stack-up	O-1	A / B / C / D	PT266
		4 ISR > 1.078" Brg O.D./2.121" Stack-up	O-1	E / H	PT266
		4 ISR > 1.188" Brg O.D./2.187" Stack-up	O-1	F / G	PT297
		4 ISR > 1.063" Brg O.D./2.183" Stack-up	O-1	F / G	PT260
W150 1/2 TON PICKUP 4WD					
82-93 All Models					
		4 ISR > 1.125" Brg O.D./2.555 Stack-up	N-1	D / E	PT3105
		4 ISR > 1.078" Brg O.D./2.121" Stack-up	N-1	A / B / C / H	PT266
		4 ISR > 1.188" Brg O.D./2.187" Stack-up	N-1	F / G	PT297
80-81 All Models					
		4 ISR > 1.125" Brg O.D./2.555 Stack-up	N-1	D / E	PT3105
		4 ISR > 1.078" Brg O.D./2.121" Stack-up	N-1	A / B / C / H	PT266
		4 ISR > 1.125" Brg O.D./2.619" Stack-up	N-1	B	PT231
		4 ISR > 1.188" Brg O.D./2.187" Stack-up	N-1	F / G	PT297

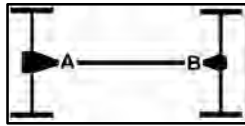

APPLICATION A-1

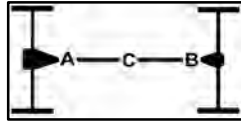

APPLICATION B-1

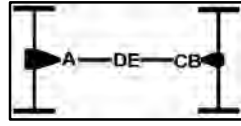

APPLICATION C-1

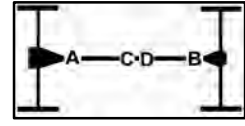

APPLICATION D-1

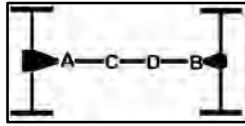

APPLICATION E-1

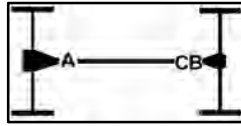

APPLICATION F-1

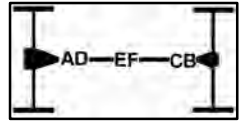

APPLICATION H-1

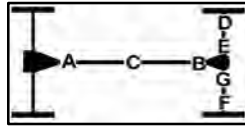

APPLICATION I-1

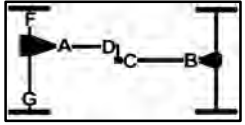

APPLICATION K-1

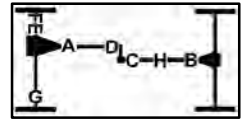

APPLICATION L-1

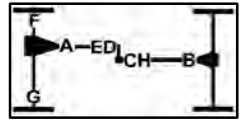

APPLICATION N-1

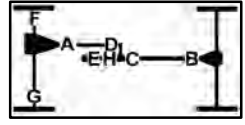

APPLICATION O-1

MAKE/YEARS FITMENT U-JOINT DESCRIPTION LOCATION POSITION PART NO.

DODGE

DODGE

MAKE/YEARS	FITMENT	U-JOINT DESCRIPTION	LOCATION	POSITION	PART NO.
W150 1/2 TON PICKUP 4WD					
77-78 All Models					
		4 ISR > 1.125" Brg O.D./2.555 Stack-up	N-1	D / E	PT3105
		4 ISR > 1.078" Brg O.D./2.121" Stack-up	N-1	A / B / C / H	PT266
		4 ISR > 1.125" Brg O.D./2.619" Stack-up	N-1	B	PT231
		4 ISR > 1.188" Brg O.D./2.187" Stack-up	N-1	F / G	PT297
1976 All Models					
		4 ISR > 1.125" Brg O.D./2.555 Stack-up	N-1	D / E	PT3105
		4 OSR > 1.063" Brg O.D./ 3.217" Stack-up	N-1	D / E	PT521HD
		4 ISR > 1.078" Brg O.D./2.121" Stack-up	N-1	A / B / C / H	PT266
		4 ISR > 1.125" Brg O.D./2.619" Stack-up	N-1	B	PT231
		4 ISR > 1.188" Brg O.D./2.187" Stack-up	N-1	F / G	PT297
W200 3/4 TON PICKUP 4WD					
1980 All Models					
		4 ISR > 1.125" Brg O.D./2.555 Stack-up	N-1	D / E	PT3105
		4 ISR > 1.078" Brg O.D./2.121" Stack-up	N-1	A / B / C / H	PT266
		4 ISR > 1.125" Brg O.D./2.619" Stack-up	N-1	B	PT231
		4 ISR > 1.375" Brg O.D./2.995" Stack-up	N-1	F / G	PT332
		4 ISR > 1.188" Brg O.D./2.187" Stack-up	N-1	F / G	PT297
75-76 All Models					
		4 ISR > 1.125" Brg O.D./2.555 Stack-up	N-1	D / E	PT3105
		4 OSR > 1.063" Brg O.D./ 3.217" Stack-up	N-1	D / E	PT521HD
		4 ISR > 1.078" Brg O.D./2.121" Stack-up	N-1	A / B / C / H	PT266
		4 ISR > 1.375" Brg O.D./2.995" Stack-up	N-1	F / G	PT332
		4 ISR > 1.188" Brg O.D./2.187" Stack-up	N-1	F / G	PT297
70-74 All Models					
		4 ISR > 1.078" Brg O.D./2.121" Stack-up	O-1	A / B / C / H	PT266
		4 OSR > 1.188" Brg O.D./3.622" Stack-up	O-1	F / G	PT578
		4 ISR > 1.063" Brg O.D./2.183" Stack-up	O-1	F / G	PT260
		4 ISR > 1.188" Brg O.D./2.187" Stack-up	O-1	F / G	PT297
W250 3/4 TON PICKUP 4WD					
92-93 All Models					
		4 ISR > 1.125" Brg O.D./2.555 Stack-up	N-1	D / E	PT3105
		4 ISR > 1.078" Brg O.D./2.121" Stack-up	N-1	A	PT266
		4 ISR > 1.125" Brg O.D./2.619" Stack-up	N-1	A / B / C / H	PT231
		4 OSR > 1.188" Brg O.D./4.182" Stack-up	N-1	B / C / H	PT560
		4 ISR > 1.375" Brg O.D./2.995" Stack-up	N-1	F / G	PT332
		4 ISR > 1.188" Brg O.D./2.187" Stack-up	N-1	F / G	PT297

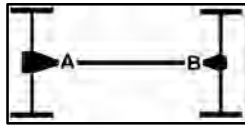

APPLICATION A-1

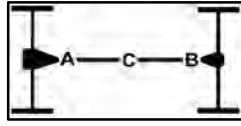

APPLICATION B-1

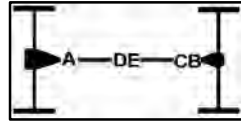

APPLICATION C-1

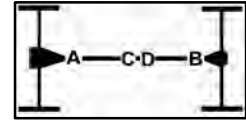

APPLICATION D-1

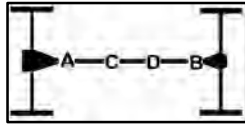

APPLICATION E-1

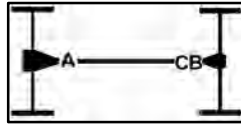

APPLICATION F-1

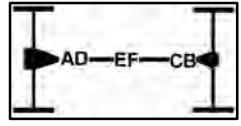

APPLICATION H-1

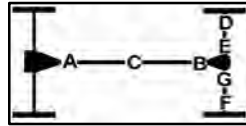

APPLICATION I-1

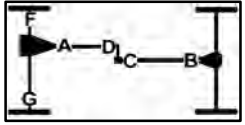

APPLICATION K-1

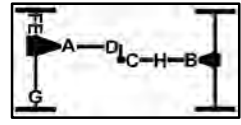

APPLICATION L-1

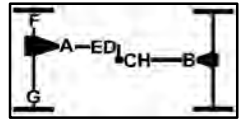

APPLICATION N-1



APPLICATION O-1

MAKE/YEARS FITMENT U-JOINT DESCRIPTION LOCATION POSITION PART NO.

DODGE

DODGE

W250 3/4 TON PICKUP 4WD					
88-91 All Models					
	4 ISR > 1.125" Brg O.D./2.555 Stack-up	N-1	D / E	PT3105	
	4 ISR > 1.078" Brg O.D./2.121" Stack-up	N-1	A / B / C / H	PT266	
	4 ISR > 1.125" Brg O.D./2.619" Stack-up	N-1	A	PT231	
	4 OSR > 1.188" Brg O.D./4.182" Stack-up	N-1	B / C / H	PT560	
	4 ISR > 1.375" Brg O.D./2.995" Stack-up	N-1	F / G	PT332	
	4 ISR > 1.188" Brg O.D./2.187" Stack-up	N-1	F / G	PT297	
82-87 All Models					
	4 ISR > 1.125" Brg O.D./2.555 Stack-up	N-1	D / E	PT3105	
	4 ISR > 1.078" Brg O.D./2.121" Stack-up	N-1	A / B / C / H	PT266	
	4 ISR > 1.375" Brg O.D./2.995" Stack-up	N-1	F / G	PT332	
	4 ISR > 1.188" Brg O.D./2.187" Stack-up	N-1	F / G	PT297	
1981 All Models					
	4 ISR > 1.125" Brg O.D./2.555 Stack-up	N-1	D / E	PT3105	
	4 ISR > 1.078" Brg O.D./2.121" Stack-up	N-1	A / B / C / H	PT266	
	4 ISR > 1.125" Brg O.D./2.619" Stack-up	N-1	B	PT231	
	4 ISR > 1.375" Brg O.D./2.995" Stack-up	N-1	F / G	PT332	
	4 ISR > 1.188" Brg O.D./2.187" Stack-up	N-1	F / G	PT297	
W300 1 TON PICKUP 4WD					
77-80 All Models					
	4 ISR > 1.125" Brg O.D./2.555 Stack-up	N-1	D / E	PT3105	
	4 ISR > 1.078" Brg O.D./2.121" Stack-up	N-1	A / B / C / H	PT266	
	4 ISR > 1.125" Brg O.D./2.619" Stack-up	N-1	B	PT231	
	4 ISR > 1.375" Brg O.D./2.995" Stack-up	N-1	F / G	PT332	
	4 ISR > 1.188" Brg O.D./2.187" Stack-up	N-1	F / G	PT297	
75-76 All Models					
	4 ISR > 1.125" Brg O.D./2.555 Stack-up	N-1	D / E	PT3105	
	4 OSR > 1.063" Brg O.D./ 3.217" Stack-up	N-1	A / D / E	PT521HD	
	4 ISR > 1.078" Brg O.D./2.121" Stack-up	N-1	A / B / C / H	PT266	
	4 ISR > 1.125" Brg O.D./2.619" Stack-up	N-1	B	PT231	
	4 ISR > 1.231" Brg O.D./2.997" Stack-up	N-1	B	PT373	
	4 ISR > 1.375" Brg O.D./2.995" Stack-up	N-1	F / G	PT332	
	4 ISR > 1.188" Brg O.D./2.187" Stack-up	N-1	F / G	PT297	
70-74 All Models					
	4 ISR > 1.231" Brg O.D./2.997" Stack-up	O-1	A / B / C / D	PT373	
	4 ISR > 1.231" Brg O.D./2.997" Stack-up	O-1	E / H	PT373	
	4 ISR > 1.125" Brg O.D./2.619" Stack-up	O-1	E	PT231	

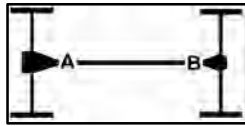

APPLICATION A-1

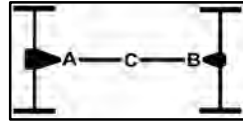

APPLICATION B-1

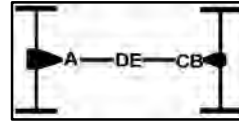

APPLICATION C-1

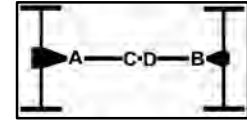

APPLICATION D-1

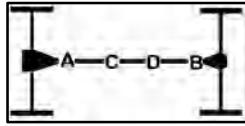

APPLICATION E-1

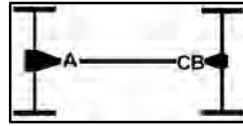

APPLICATION F-1

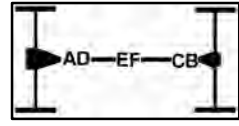

APPLICATION H-1

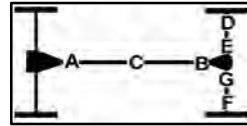

APPLICATION I-1

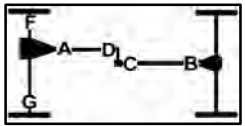

APPLICATION K-1

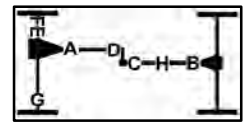

APPLICATION L-1

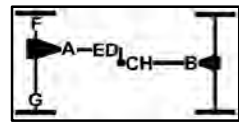

APPLICATION N-1



APPLICATION O-1

MAKE/YEARS FITMENT U-JOINT DESCRIPTION LOCATION POSITION PART NO.

DODGE

DODGE

W350 1 TON PICKUP 4WD					
92-93 All Models	4 ISR > 1.125" Brg O.D./2.555 Stack-up	N-1	D / E	PT3105	
	4 ISR > 1.078" Brg O.D./2.121" Stack-up	N-1	A	PT266	
	4 ISR > 1.125" Brg O.D./2.619" Stack-up	N-1	A / B / C	PT231	
	4 OSR > 1.188" Brg O.D./4.182" Stack-up	N-1	B / C / H	PT560	
	4 ISR > 1.375" Brg O.D./2.995" Stack-up	N-1	F / G	PT332	
	4 ISR > 1.188" Brg O.D./2.187" Stack-up	N-1	F / G	PT297	
90-91 All Models	4 ISR > 1.125" Brg O.D./2.555 Stack-up	N-1	D / E	PT3105	
	4 ISR > 1.078" Brg O.D./2.121" Stack-up	N-1	A / B / C	PT266	
	4 OSR > 1.188" Brg O.D./4.182" Stack-up	N-1	B / C	PT560	
	4 ISR > 1.375" Brg O.D./2.995" Stack-up	N-1	F / G	PT332	
	4 ISR > 1.188" Brg O.D./2.187" Stack-up	N-1	F / G	PT297	
	82-89 All Models	4 ISR > 1.125" Brg O.D./2.555 Stack-up	N-1	D / E	PT3105
4 ISR > 1.078" Brg O.D./2.121" Stack-up		N-1	A / B / C / H	PT266	
4 ISR > 1.231" Brg O.D./2.997" Stack-up		N-1	B / C	PT373	
4 OSR > 1.188" Brg O.D./4.182" Stack-up		N-1	B / C	PT560	
4 ISR > 1.375" Brg O.D./2.995" Stack-up		N-1	F / G	PT332	
4 ISR > 1.188" Brg O.D./2.187" Stack-up		N-1	F / G	PT297	
1981 All Models	4 ISR > 1.125" Brg O.D./2.555 Stack-up	N-1	D / E	PT3105	
	4 ISR > 1.078" Brg O.D./2.121" Stack-up	N-1	A / B / C / H	PT266	
	4 ISR > 1.125" Brg O.D./2.619" Stack-up	N-1	B	PT231	
	4 ISR > 1.375" Brg O.D./2.995" Stack-up	N-1	F / G	PT332	
	4 ISR > 1.188" Brg O.D./2.187" Stack-up	N-1	F / G	PT297	

FIAT

FIAT

124	70-78 All Models	4 OSR > .938" Brg O.D./2.407" Stack-up	A-1	A / B	PT514
128	71-79 All Models	4 OSR > .938" Brg O.D./2.407" Stack-up	A-1	A / B	PT514
131	75-78 All Models	4 OSR > .938" Brg O.D./2.407" Stack-up	A-1	A / B	PT514
850	70-73 All Models	4 OSR > .938" Brg O.D./2.407" Stack-up	A-1	A / B	PT514

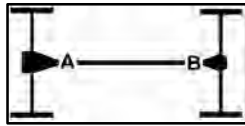

APPLICATION A-1

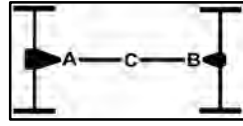

APPLICATION B-1

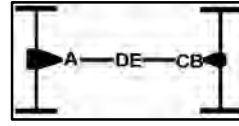

APPLICATION C-1

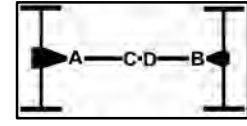

APPLICATION D-1

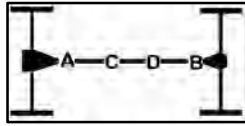

APPLICATION E-1

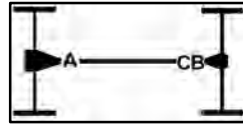

APPLICATION F-1

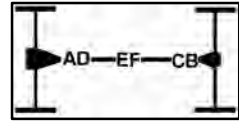

APPLICATION H-1

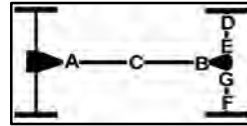

APPLICATION I-1

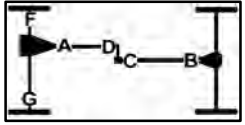

APPLICATION K-1

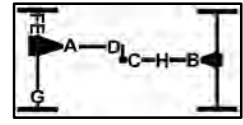

APPLICATION L-1

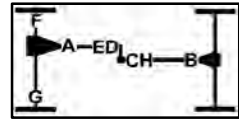

APPLICATION N-1

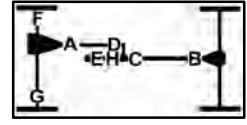

APPLICATION O-1

MAKE/YEARS FITMENT U-JOINT DESCRIPTION LOCATION POSITION PART NO.

FIAT

FIAT

BRAVA					
79-81	All Models	4 OSR > .938" Brg O.D./2.407" Stack-up	A-1	A / B	PT514
SPIDER					
79-83	All Models	4 OSR > .938" Brg O.D./2.407" Stack-up	A-1	A / B	PT514
X1/9					
74-83	All Models	4 OSR > .938" Brg O.D./2.407" Stack-up	A-1	A / B	PT514

FORD

FORD

AEROSTAR FWD						
90-97	All Models	4 OSR > 1.063" Brg O.D/ 3.217" Stack-up	A-1	A / B	PT521HD	
		4 OSR > 1.063" Brg O.D/ 3.622" Stack-up	A-1	A / B	PT530	
86-89	All Models	4 OSR > 1.063" Brg O.D/ 3.217" Stack-up	A-1	A / B	PT521HD	
		2ISR & 2OSR > 1.063"/1.125" Bearing caps	A-1	B	PT675	
AEROSTAR AWD						
90-97	All Models	4 OSR > 1.063" Brg O.D/2.437" Stack-up	L-1	A / D / E / F	PT315	
		4 OSR > 1.063" Brg O.D/ 3.217" Stack-up	L-1	B / C	PT521HD	
BRONCO (FULL SIZE) 4WD						
86-96	All Models - Exc. 5 Spd. M/T	2 ISR & 2 OSR > 1.063"/1.125" Brg O.D/ 2.767" ISR	N-1	A / D	PT1204	
		4 OSR > 1.063" Brg O.D/ 3.622" Stack-up	N-1	B / C / H	PT530	
	All Models - 5 Spd. M/T	4 OSR > 1.063" Brg O.D/ 3.622" Stack-up	N-1	A	PT530	
		2 ISR & 2 OSR > 1.063"/1.125" Brg O.D/ 2.555" ISR	N-1	D	PT3188	
		2 ISR & 2 OSR > 1.063"/1.125" Brg O.D/ 2.767" ISR	N-1	B / C / H	PT1204	
	All Models	4 ISR > 1.188" Brg O.D./2.187" Stack-up	N-1	E / F / G	PT297	
	1988	All Models	2 ISR & 2 OSR > 1.063"/1.125" Brg O.D/ 2.767" ISR	N-1	A / D	PT1204
			All Models - Exc. 5 Spd. M/T	4 OSR > 1.063" Brg O.D/ 3.622" Stack-up	N-1	C
		All Models - 5 Spd. M/T	2 ISR & 2 OSR > 1.063"/1.125" Brg O.D/ 2.767" ISR	N-1	B / C / H	PT1204
		All Models	4 ISR > 1.188" Brg O.D./2.187" Stack-up	N-1	E / F / G	PT297

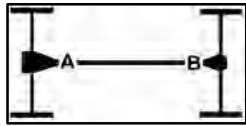

APPLICATION A-1

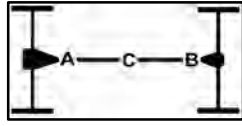

APPLICATION B-1

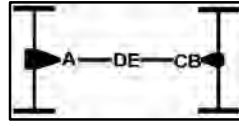

APPLICATION C-1

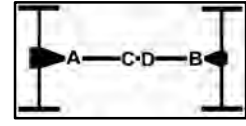

APPLICATION D-1

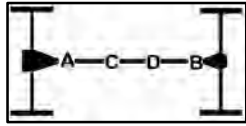

APPLICATION E-1

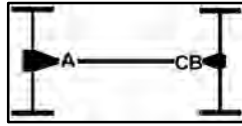

APPLICATION F-1

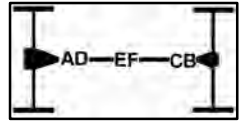

APPLICATION H-1

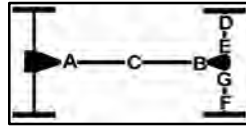

APPLICATION I-1

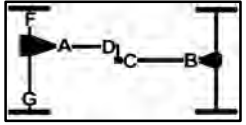

APPLICATION K-1

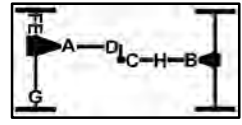

APPLICATION L-1

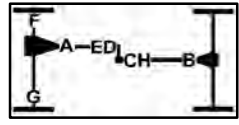

APPLICATION N-1



APPLICATION O-1

MAKE/YEARS FITMENT U-JOINT DESCRIPTION LOCATION POSITION PART NO.

FORD

FORD

MAKE/YEARS	FITMENT	U-JOINT DESCRIPTION	LOCATION	POSITION	PART NO.
BRONCO (FULL SIZE) 4WD					
82-87	All Models	2 ISR & 2 OSR > 1.063"/1.125" Brg O.D/ 2.767" ISR	N-1	A / B / D	PT1204
		4 OSR > 1.063" Brg O.D/ 3.622" Stack-up	N-1	C / D / H	PT530
		4 ISR > 1.188" Brg O.D./2.187" Stack-up	N-1	E / F / G	PT297
80-81	All Models - To Serial # GJ0,000	4 OSR > 1.063" Brg O.D/ 3.622" Stack-up	N-1	D	PT530
		2 ISR & 2 OSR > 1.063"/1.125" Brg O.D/ 2.767" ISR	N-1	A	PT1204
	All Models - From Serial # GJ0,000	4 OSR > 1.063" Brg O.D/ 3.622" Stack-up	N-1	A	PT530
		2 ISR & 2 OSR > 1.063"/1.125" Brg O.D/ 2.767" ISR	N-1	D	PT1204
	All Models	4 OSR > 1.063" Brg O.D/ 3.622" Stack-up	N-1	C / H	PT530
		2 ISR & 2 OSR > 1.063"/1.125" Brg O.D/ 2.767" ISR	N-1	B	PT1204
		4 ISR > 1.188" Brg O.D./2.187" Stack-up	N-1	E / F / G	PT297
1979	All Models	4 OSR > 1.063" Brg O.D/ 3.622" Stack-up	N-1	A / D / E	PT530
		4 OSR > 1.063" Brg O.D/ 3.622" Stack-up	N-1	C / H	PT530
		2 ISR & 2 OSR > 1.063"/1.125" Brg O.D/ 2.767" ISR	N-1	A / B	PT1204
		4 ISR > 1.188" Brg O.D./2.187" Stack-up	N-1	F / G	PT297
1978	All Models	4 OSR > 1.063" Brg O.D/ 3.217" Stack-up	N-1	A / D / E	PT521HD
		4 OSR > 1.063" Brg O.D/ 3.217" Stack-up	N-1	B / C / H	PT521HD
		4 OSR > 1.063" Brg O.D/ 3.622" Stack-up	N-1	A / B	PT530
		4 ISR > 1.188" Brg O.D./2.187" Stack-up	N-1	F / G	PT297
70-77	All Models	4 OSR > 1.063" Brg O.D/ 3.217" Stack-up	N-1	A / D / E	PT521HD
		4 OSR > 1.063" Brg O.D/ 3.217" Stack-up	N-1	B / C / H	PT521HD
		4 ISR > 1.063" Brg O.D/2.183" Stack-up	N-1	F / G	PT260
BRONCO II 4WD					
1990	All Models	4 OSR > 1.063" Brg O.D/ 3.217" Stack-up	N-1	A / D / E	PT521HD
		4 ISR > 1.188" Brg O.D./2.187" Stack-up	L-1	E / F / G	PT297
		4 ISR & 4 OSR > 1.063" Brg O.D/1.635"ISR - 2.437 OSR Stack-up	L-1	E / F / G	PT456
86-89	All Models	4 OSR > 1.063" Brg O.D/ 3.217" Stack-up	L-1	A / D	PT521HD
		4 ISR & 4 OSR > 1.063" Brg O.D/1.635"ISR - 2.437 OSR Stack-up	L-1	E / F / G	PT456
84-85	All Models - 5 Spd. M/T	4 OSR > 1.063" Brg O.D/ 3.217" Stack-up	L-1	A	PT521HD
		4 OSR > 1.063" Brg O.D/2.437" Stack-up	L-1	D	PT315
	All Models - 5 Spd. M/T - From Sept. 1983	4 OSR > 1.063" Brg O.D/ 3.217" Stack-up	L-1	A / D	PT521HD

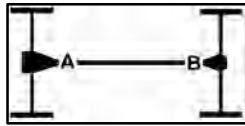

APPLICATION A-1

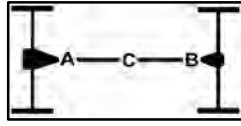

APPLICATION B-1

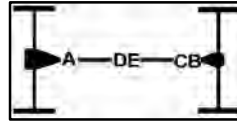

APPLICATION C-1

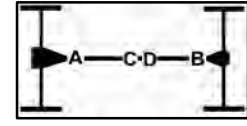

APPLICATION D-1

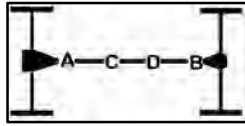

APPLICATION E-1

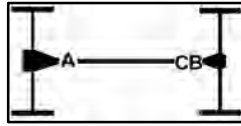

APPLICATION F-1

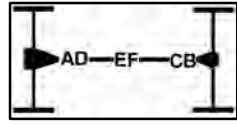

APPLICATION H-1

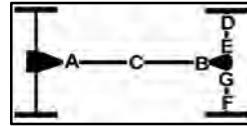

APPLICATION I-1

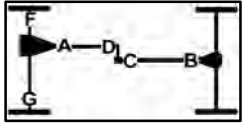

APPLICATION K-1

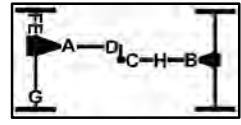

APPLICATION L-1

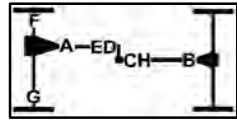

APPLICATION N-1

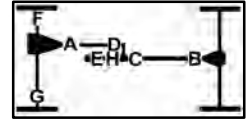

APPLICATION O-1

MAKE/YEARS FITMENT U-JOINT DESCRIPTION LOCATION POSITION PART NO.

FORD

FORD

MAKE/YEARS	FITMENT	U-JOINT DESCRIPTION	LOCATION	POSITION	PART NO.
BRONCO II 4WD					
84-85	All Models - Exc. 5 Spd. M/T	4 OSR > 1.063" Brg O.D/ 3.217" Stack-up	L-1	A / D	PT521HD
	All Models	4 OSR > 1.063" Brg O.D/2.437" Stack-up	L-1	B / C / H	PT315
		4 ISR & 4 OSR > 1.063" Brg O.D/1.635"ISR - 2.437 OSR Stack-up	L-1	E / F / G	PT456
COUNTRY SEDAN					
70-74	All Models	4 OSR > 1.063" Brg O.D/ 3.217" Stack-up	A-1	A	PT521HD
		4 OSR > 1.063" Brg O.D/ 3.622" Stack-up	A-1	A	PT530
		2ISR & 2OSR > 1.063"/1.125" Bearing caps	A-1	B	PT675
		2 ISR & 2 OSR > 1.063"/1.125" Brg O.D/ 2.767" ISR	A-1	B	PT1204
COUNTRY SQUIRE					
1979	All Models-With Towing Option	4 OSR > 1.063" Brg O.D/ 3.622" Stack-up	A-1	A	PT530
	All Models-Without Towing Option	4 OSR > 1.063" Brg O.D/ 3.217" Stack-up	A-1	A	PT521HD
75-76	All Models - 302 V-8 Engine	4 OSR > 1.063" Brg O.D/ 3.217" Stack-up	A-1	A	PT521HD
		2ISR & 2OSR > 1.063"/1.125" Bearing caps	A-1	B	PT675
	All Models - 351 V-8 Engine	4 OSR > 1.063" Brg O.D/ 3.217" Stack-up	A-1	A	PT521HD
		2ISR & 2OSR > 1.063"/1.125" Bearing caps	A-1	B	PT675
		4 OSR > 1.063" Brg O.D/ 3.622" Stack-up	A-1	A	PT530
		2 ISR & 2 OSR > 1.063"/1.125" Brg O.D/ 2.767" ISR	A-1	B	PT1204
	All Models - 400 or 460 V-8 Engine	4 OSR > 1.063" Brg O.D/ 3.622" Stack-up	A-1	A	PT530
		2 ISR & 2 OSR > 1.063"/1.125" Brg O.D/ 2.767" ISR	A-1	B	PT1204
70-74	All Models	4 OSR > 1.063" Brg O.D/ 3.217" Stack-up	A-1	A	PT521HD
		4 OSR > 1.063" Brg O.D/ 3.622" Stack-up	A-1	A	PT530
		2ISR & 2OSR > 1.063"/1.125" Bearing caps	A-1	B	PT675
		2 ISR & 2 OSR > 1.063"/1.125" Brg O.D/ 2.767" ISR	A-1	B	PT1204
COURIER 2WD					
72-82	All Models - 2 or 3 Joint Driveshaft	4 ISR > 1.102" Brg O.D./2.323" Stack-up	B-1	A / B / C	PT1610
CROWN VICTORIA					
95-06	All Models	4 OSR > 1.063" Brg O.D/ 3.622" Stack-up	A-1	A / B	PT530

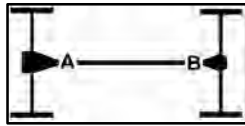

APPLICATION A-1

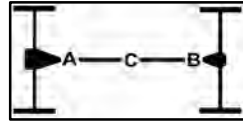

APPLICATION B-1

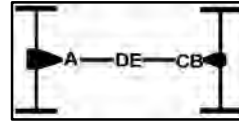

APPLICATION C-1

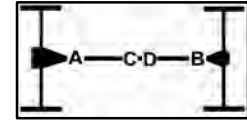

APPLICATION D-1

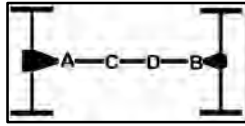

APPLICATION E-1

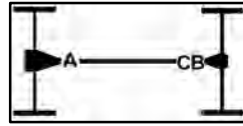

APPLICATION F-1

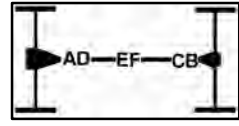

APPLICATION H-1

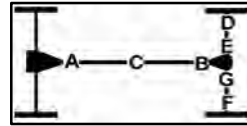

APPLICATION I-1

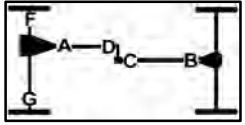

APPLICATION K-1

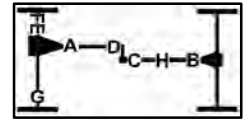

APPLICATION L-1

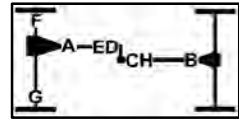

APPLICATION N-1

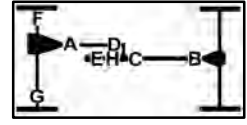

APPLICATION O-1

MAKE/YEARS FITMENT U-JOINT DESCRIPTION LOCATION POSITION PART NO.

FORD

FORD

MAKE/YEARS	FITMENT	U-JOINT DESCRIPTION	LOCATION	POSITION	PART NO.
CROWN VICTORIA					
92-94	All Models-With Towing Option	4 OSR > 1.063" Brg O.D/ 3.622" Stack-up	A-1	A	PT530
	All Models-Without Towing Option	4 OSR > 1.063" Brg O.D/ 3.217" Stack-up	A-1	A	PT521HD
CUSTOM 500					
75-77	All Models - 302 V-8 Engine	4 OSR > 1.063" Brg O.D/ 3.217" Stack-up	A-1	A	PT521HD
		2ISR & 2OSR > 1.063"/1.125" Bearing caps	A-1	B	PT675
	All Models - 351 V-8 Engine	4 OSR > 1.063" Brg O.D/ 3.217" Stack-up	A-1	A	PT521HD
		2ISR & 2OSR > 1.063"/1.125" Bearing caps	A-1	B	PT675
		4 OSR > 1.063" Brg O.D/ 3.622" Stack-up	A-1	A	PT530
		2 ISR & 2 OSR > 1.063"/1.125" Brg O.D/ 2.767" ISR	A-1	B	PT1204
	All Models - 400 or 460 V-8 Engine	4 OSR > 1.063" Brg O.D/ 3.622" Stack-up	A-1	A	PT530
		2 ISR & 2 OSR > 1.063"/1.125" Brg O.D/ 2.767" ISR	A-1	B	PT1204
70-74	All Models	4 OSR > 1.063" Brg O.D/ 3.217" Stack-up	A-1	A	PT521HD
		4 OSR > 1.063" Brg O.D/ 3.622" Stack-up	A-1	A	PT530
		2ISR & 2OSR > 1.063"/1.125" Bearing caps	A-1	B	PT675
		2 ISR & 2 OSR > 1.063"/1.125" Brg O.D/ 2.767" ISR	A-1	B	PT1204
E100 1/2 TON VAN 2WD					
79-83	All Models - 2 or 3 Joint Driveshaft	4 OSR > 1.063" Brg O.D/ 3.622" Stack-up	B-1	A / C	PT530
		2 ISR & 2 OSR > 1.063"/1.125" Brg O.D/ 2.767" ISR	B-1	B	PT1204
75-78	All Models - 2 Joint Driveshaft - 124" WB	4 OSR > 1.063" Brg O.D/ 3.217" Stack-up	A-1	A	PT521HD
		2ISR & 2OSR > 1.063"/1.125" Bearing caps	A-1	B	PT675
	All Models - 2 Joint Driveshaft - Exc. 124" WB	4 OSR > 1.063" Brg O.D/ 3.217" Stack-up	A-1	A / B	PT521HD
	All Models - 3 Joint Driveshaft - 4.9L	4 OSR > 1.063" Brg O.D/ 3.217" Stack-up	B-1	A / B / C	PT521HD
	All Models - 3 Joint Driveshaft - 5.8L	4 OSR > 1.063" Brg O.D/ 3.622" Stack-up	B-1	A / C	PT530
		4 OSR > 1.063" Brg O.D/ 3.217" Stack-up	B-1	B	PT521HD
70-74	All Models - 2 or 3 Joint Driveshaft	4 OSR > 1.063" Brg O.D/ 3.217" Stack-up	B-1	A / B / C	PT521HD
E150 1/2 TON VAN 2WD					
97-06	All Models	4 OSR > 1.188" Brg O.D./3.622" Stack-up	A-1	A / B	PT578
89-96	All Models - 2 or 3 Joint Driveshaft	4 OSR > 1.063" Brg O.D/ 3.622" Stack-up	B-1	A / B / C	PT530

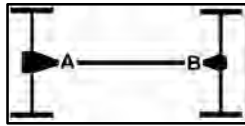

APPLICATION A-1

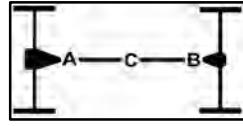

APPLICATION B-1

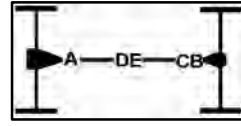

APPLICATION C-1

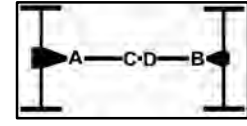

APPLICATION D-1

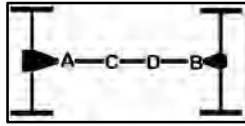

APPLICATION E-1

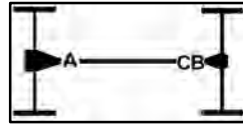

APPLICATION F-1

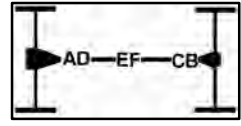

APPLICATION H-1

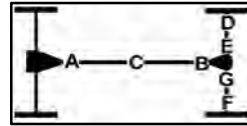

APPLICATION I-1

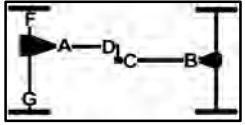

APPLICATION K-1

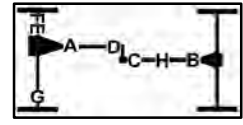

APPLICATION L-1

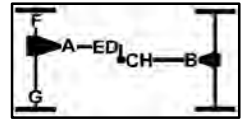

APPLICATION N-1

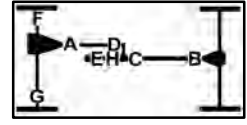

APPLICATION O-1

MAKE/YEARS FITMENT U-JOINT DESCRIPTION LOCATION POSITION PART NO.

FORD

FORD

MAKE/YEARS	FITMENT	U-JOINT DESCRIPTION	LOCATION	POSITION	PART NO.
E150 1/2 TON VAN 2WD					
79-88	All Models	2 or 3 Joint Driveshaft			
		4 OSR > 1.063" Brg O.D/ 3.622" Stack-up	B-1	A / C	PT530
		2 ISR & 2 OSR > 1.063"/1.125" Brg O.D/ 2.767" ISR	B-1	B	PT1204
75-78	All Models	2 Joint Driveshaft - 124" WB			
		4 OSR > 1.063" Brg O.D/ 3.217" Stack-up	A-1	A	PT521HD
		2ISR & 2OSR > 1.063"/1.125" Bearing caps	A-1	B	PT675
	All Models	2 Joint Driveshaft - Exc. 124" WB			
		4 OSR > 1.063" Brg O.D/ 3.217" Stack-up	A-1	A / B	PT521HD
	All Models	3 Joint Driveshaft - 4.9L			
		4 OSR > 1.063" Brg O.D/ 3.217" Stack-up	B-1	A / B / C	PT521HD
	All Models	3 Joint Driveshaft - 5.8L			
		4 OSR > 1.063" Brg O.D/ 3.622" Stack-up	B-1	A / C	PT530
		4 OSR > 1.063" Brg O.D/ 3.217" Stack-up	B-1	B	PT521HD
E200 3/4 TON VAN 2WD					
70-74	All Models	2 or 3 Joint Driveshaft			
		4 OSR > 1.063" Brg O.D/ 3.217" Stack-up	B-1	A / B / C	PT521HD
E250 3/4 TON VAN 2WD					
97-06	All Models				
		4 OSR > 1.188" Brg O.D./3.622" Stack-up	A-1	A / B	PT578
89-96	All Models	2 or 3 Joint Driveshaft			
		4 OSR > 1.063" Brg O.D/ 3.622" Stack-up	B-1	A / C	PT530
		2 ISR & 2 OSR > 1.063"/1.125" Brg O.D/ 2.767" ISR	B-1	B / C	PT1204
87-88	All Models				
		4 OSR > 1.063" Brg O.D/ 3.622" Stack-up	A-1	A	PT530
		2 ISR & 2 OSR > 1.063"/1.125" Brg O.D/ 2.767" ISR	A-1	B	PT1204
84-86	All Models	2 Joint Driveshaft			
		4 OSR > 1.063" Brg O.D/ 3.622" Stack-up	A-1	A	PT530
		2 ISR & 2 OSR > 1.063"/1.125" Brg O.D/ 2.767" ISR	A-1	B	PT1204
	All Models	3 Joint Driveshaft - A/T			
		4 OSR > 1.063" Brg O.D/ 3.622" Stack-up	B-1	A / C	PT530
		2 ISR & 2 OSR > 1.063"/1.125" Brg O.D/ 2.767" ISR	B-1	B	PT1204
	All Models	3 Joint Driveshaft - M/T			
		4 OSR > 1.063" Brg O.D/ 3.622" Stack-up	B-1	C	PT530
		2 ISR & 2 OSR > 1.063"/1.125" Brg O.D/ 2.767" ISR	B-1	A / B	PT1204
79-83	All Models	2 or 3 Joint Driveshaft			
		4 OSR > 1.063" Brg O.D/ 3.622" Stack-up	B-1	A / C	PT530
		2 ISR & 2 OSR > 1.063"/1.125" Brg O.D/ 2.767" ISR	B-1	B	PT1204
75-78	All Models	2 or 3 Joint Driveshaft			
		4 OSR > 1.063" Brg O.D/ 3.622" Stack-up	B-1	A / B / C	PT530

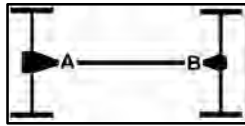

APPLICATION A-1

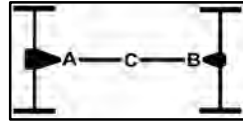

APPLICATION B-1

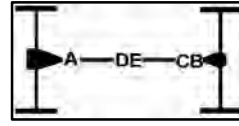

APPLICATION C-1

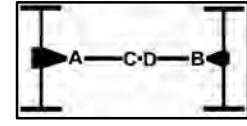

APPLICATION D-1

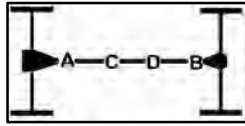

APPLICATION E-1

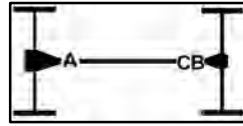

APPLICATION F-1

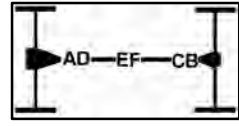

APPLICATION H-1

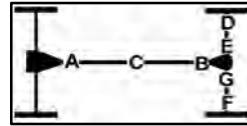

APPLICATION I-1

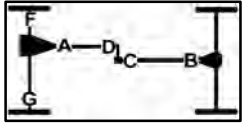

APPLICATION K-1

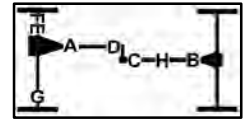

APPLICATION L-1

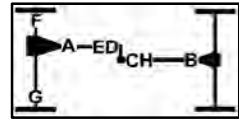

APPLICATION N-1

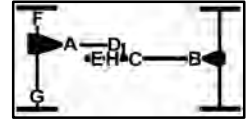

APPLICATION O-1

MAKE/YEARS FITMENT U-JOINT DESCRIPTION LOCATION POSITION PART NO.

FORD

FORD

MAKE/YEARS	FITMENT	U-JOINT DESCRIPTION	LOCATION	POSITION	PART NO.
E300 1 TON VAN 2WD					
70-74 All Models - 2 or 3 Joint Driveshaft					
		4 OSR > 1.063" Brg O.D./ 3.217" Stack-up	B-1	A / B / C	PT521HD
		4 OSR > 1.188" Brg O.D./3.622" Stack-up	B-1	A / B / C	PT578
E350 1 TON VAN 2WD					
2004 All Models					
		4 OSR > 1.188" Brg O.D./3.622" Stack-up	A-1	A / B	PT578
		4 OSR > 1.188" Brg O.D./4.182" Stack-up	A-1	A / B	PT560
90-03 All Models - 2 Joint Driveshaft					
		4 OSR > 1.063" Brg O.D/ 3.622" Stack-up	A-1	A / B	PT530
		2 ISR & 2 OSR > 1.063"/1.125" Brg O.D/ 2.767" ISR	A-1	A / B	PT1204
		4 OSR > 1.188" Brg O.D./3.622" Stack-up	A-1	A / B	PT578
All Models - 3 Joint Driveshaft					
		4 OSR > 1.063" Brg O.D/ 3.622" Stack-up	B-1	A / C	PT530
		2 ISR & 2 OSR > 1.063"/1.125" Brg O.D/ 2.767" ISR	B-1	B	PT1204
		4 OSR > 1.188" Brg O.D./3.622" Stack-up	B-1	A / B / C	PT578
1989 All Models - 2 or 3 Joint Driveshaft					
		4 OSR > 1.063" Brg O.D/ 3.622" Stack-up	B-1	A / C	PT530
		2 ISR & 2 OSR > 1.063"/1.125" Brg O.D/ 2.767" ISR	B-1	B / C	PT1204
80-88 All Models - 2 Joint Driveshaft					
		4 OSR > 1.063" Brg O.D/ 3.622" Stack-up	A-1	A	PT530
		2 ISR & 2 OSR > 1.063"/1.125" Brg O.D/ 2.767" ISR	A-1	B	PT1204
All Models - 3 Joint Driveshaft					
		4 OSR > 1.063" Brg O.D/ 3.622" Stack-up	B-1	A / C	PT530
		2 ISR & 2 OSR > 1.063"/1.125" Brg O.D/ 2.767" ISR	B-1	A / B	PT1204
1979 All Models - 2 Joint Driveshaft					
		4 OSR > 1.063" Brg O.D/ 3.622" Stack-up	A-1	A	PT530
		2 ISR & 2 OSR > 1.063"/1.125" Brg O.D/ 2.767" ISR	A-1	B	PT1204
All Models - 3 Joint Driveshaft					
		4 OSR > 1.063" Brg O.D/ 3.622" Stack-up	B-1	A / C	PT530
		4 OSR > 1.188" Brg O.D./3.622" Stack-up	B-1	B / C	PT578
		2 ISR & 2 OSR > 1.063"/1.125" Brg O.D/ 2.767" ISR	B-1	B	PT1204
75-78 All Models - 2 or 3 Joint Driveshaft					
		4 OSR > 1.063" Brg O.D/ 3.622" Stack-up	B-1	A / B / C	PT530
E SUPER DUTY					
97-98 All Models - 2 or 3 Joint Driveshaft					
		4 OSR > 1.188" Brg O.D./4.182" Stack-up	B-1	A / B / C	PT560
E450					
05-06 All Models					
		4 OSR > 1.188" Brg O.D./4.182" Stack-up	B-1	A / B / C	PT560
02-04 All Models					
		4 OSR > 1.188" Brg O.D./4.182" Stack-up	B-1	A / B / C	PT560
		4 OSR > 1.188" Brg O.D./3.622" Stack-up	B-1	A / B / C	PT578

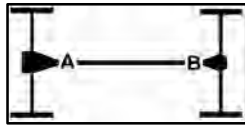

APPLICATION A-1

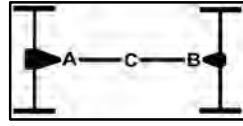

APPLICATION B-1

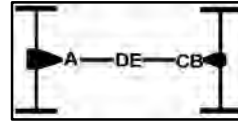

APPLICATION C-1

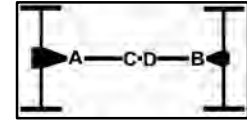

APPLICATION D-1

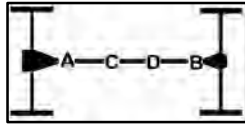

APPLICATION E-1

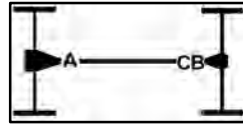

APPLICATION F-1

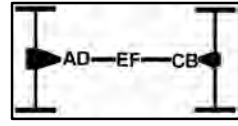

APPLICATION H-1

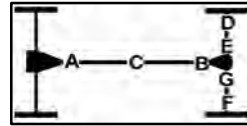

APPLICATION I-1

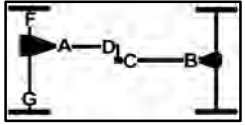

APPLICATION K-1

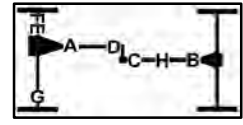

APPLICATION L-1

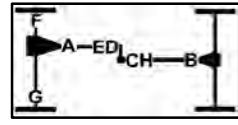

APPLICATION N-1

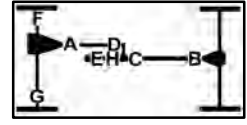

APPLICATION O-1

MAKE/YEARS FITMENT U-JOINT DESCRIPTION LOCATION POSITION PART NO.

FORD

FORD

MAKE/YEARS	FITMENT	U-JOINT DESCRIPTION	LOCATION	POSITION	PART NO.
E450					
99-01	All Models	2 or 3 Joint Driveshaft			
		4 OSR > 1.188" Brg O.D./4.182" Stack-up	B-1	A / B / C	PT560
EXCURSION 2WD					
00-04	All Models	5.4L			
		4 OSR > 1.188" Brg O.D./3.622" Stack-up	A-1	A / B	PT578
		All Models - 6.0L Dsl, 7.3L Dsl or 6.8L			
		4 OSR > 1.188" Brg O.D./4.182" Stack-up	A-1	A / B	PT560
EXCURSION 4WD					
00-04	All Models				
		4 OSR > 1.188" Brg O.D./3.622" Stack-up	N-1	A / D / E	PT578
		4 OSR > 1.188" Brg O.D./3.622" Stack-up	N-1	B / C	PT578
		4 OSR > 1.188" Brg O.D./4.182" Stack-up	N-1	B / C	PT560
		4 ISR > 1.375" Brg O.D./2.995" Stack-up	N-1	F / G	PT332
EXPEDITION 2WD					
03-06	All Models				
		4 OSR > 1.188" Brg O.D./3.622" Stack-up	A-1	B	PT578
97-02	All Models	4.6L			
		4 OSR > 1.063" Brg O.D./ 3.622" Stack-up	A-1	A / B	PT530
		4 OSR > 1.188" Brg O.D./3.622" Stack-up	A-1	A / B	PT578
		All Models - 5.4L			
		4 OSR > 1.188" Brg O.D./3.622" Stack-up	A-1	A / B	PT578
EXPEDITION 4WD					
97-06	All Models				
		4 OSR > 1.063" Brg O.D./ 3.622" Stack-up	L-1	A / D	PT530
		4 OSR > 1.188" Brg O.D./3.622" Stack-up	L-1	B / C	PT578
EXPLORER 2WD (INCLUDES SPORT, SPORT TRAC)					
00-06	All Models				
		4 OSR > 1.063" Brg O.D./ 3.622" Stack-up	A-1	A / B	PT530
97-99	All Models				
		4 OSR > 1.063" Brg O.D./ 3.622" Stack-up	A-1	A / B	PT530
		2 ISR & 2 OSR > 1.063"/1.125" Brg O.D./ 2.767" ISR	A-1	A / B	PT1204
95-96	All Models				
		4 OSR > 1.063" Brg O.D/ 3.217" Stack-up	A-1	A / B	PT521HD
		4 OSR > 1.063" Brg O.D/ 3.622" Stack-up	A-1	A / B	PT530
91-94	All Models				
		4 OSR > 1.063" Brg O.D/ 3.217" Stack-up	A-1	A / B	PT521HD
EXPLORER 4WD (INCLUDES SPORT, SPORT TRAC)					
95-06	All Models				
		4 OSR > 1.063" Brg O.D/ 3.217" Stack-up	K-1	A / D	PT521HD
		4 OSR > 1.063" Brg O.D/ 3.622" Stack-up	K-1	B / C	PT530

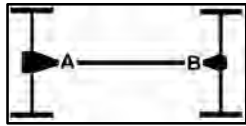

APPLICATION A-1

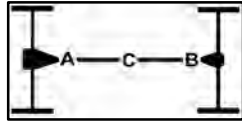

APPLICATION B-1

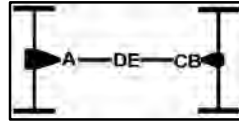

APPLICATION C-1

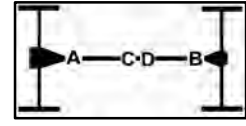

APPLICATION D-1

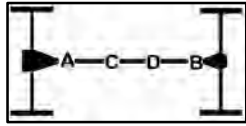

APPLICATION E-1

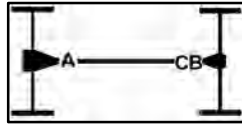

APPLICATION F-1

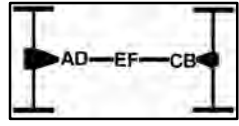

APPLICATION H-1

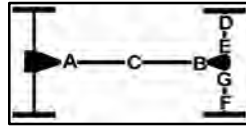

APPLICATION I-1

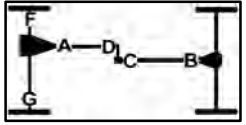

APPLICATION K-1

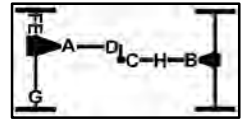

APPLICATION L-1

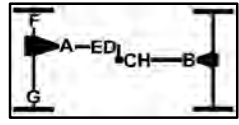

APPLICATION N-1



APPLICATION O-1

MAKE/YEARS FITMENT U-JOINT DESCRIPTION LOCATION POSITION PART NO.

FORD

FORD

EXPLORER 4WD (INCLUDES SPORT, SPORT TRAC)					
91-94 All Models	4 OSR > 1.063" Brg O.D/ 3.217" Stack-up	L-1	A / B / C / D		PT521HD
	4 OSR > 1.063" Brg O.D/ 3.622" Stack-up	L-1	B / C		PT530
	4 ISR > 1.188" Brg O.D./2.187" Stack-up	L-1	E / F / G		PT297
	4 ISR & 4 OSR > 1.063" Brg O.D/1.635"ISR - 2.437 OSR Stack-up	L-1	E / F / G		PT456
F100 1/2 TON PICKUP 2WD					
82-83 All Models - 2 Joint Driveshaft	4 OSR > 1.063" Brg O.D/ 3.622" Stack-up	A-1	A		PT530
	2 ISR & 2 OSR > 1.063"/1.125" Brg O.D/ 2.767" ISR	A-1	B		PT1204
All Models - 3 Joint Driveshaft	4 OSR > 1.063" Brg O.D/ 3.622" Stack-up	B-1	A / C		PT530
	2 ISR & 2 OSR > 1.063"/1.125" Brg O.D/ 2.767" ISR	B-1	A / B		PT1204
1981 All Models - 2 Joint Driveshaft	4 OSR > 1.063" Brg O.D/ 3.622" Stack-up	A-1	A		PT530
	2 ISR & 2 OSR > 1.063"/1.125" Brg O.D/ 2.767" ISR	A-1	B		PT1204
	4 ISR > 1.125" Brg O.D./2.555 Stack-up	A-1	A / B		PT3105
All Models - 3 Joint Driveshaft	4 OSR > 1.063" Brg O.D/ 3.622" Stack-up	B-1	A / C		PT530
	2 ISR & 2 OSR > 1.063"/1.125" Brg O.D/ 2.767" ISR	B-1	A / B		PT1204
1980 All Models - 2 Joint Driveshaft	4 OSR > 1.063" Brg O.D/ 3.622" Stack-up	A-1	A		PT530
	2 ISR & 2 OSR > 1.063"/1.125" Brg O.D/ 2.767" ISR	A-1	B		PT1204
	All Models - 3 Joint Driveshaft				
	4 OSR > 1.063" Brg O.D/ 3.622" Stack-up	B-1	A / C		PT530
	2 ISR & 2 OSR > 1.063"/1.125" Brg O.D/ 2.767" ISR	B-1	A / B		PT1204
1979 All Models - 2 Joint Driveshaft	4 OSR > 1.063" Brg O.D/ 3.622" Stack-up	A-1	A		PT530
	2 ISR & 2 OSR > 1.063"/1.125" Brg O.D/ 2.767" ISR	A-1	B		PT1204
	4 OSR > 1.063" Brg O.D/ 3.217" Stack-up	A-1	A / B		PT521HD
	All Models - 3 Joint Driveshaft				
	4 OSR > 1.063" Brg O.D/ 3.622" Stack-up	B-1	A / C		PT530
	2 ISR & 2 OSR > 1.063"/1.125" Brg O.D/ 2.767" ISR	B-1	A / B		PT1204
73-78 All Models - 7.5L - 2 or 3 Joint Driveshaft	4 OSR > 1.063" Brg O.D/ 3.622" Stack-up	B-1	A / C		PT530
	2 ISR & 2 OSR > 1.063"/1.125" Brg O.D/ 2.767" ISR	B-1	B		PT1204
	All Models - Exc. 7.5L - Regular Cab, Super Cab				
	4 OSR > 1.063" Brg O.D/ 3.217" Stack-up	B-1	A / B / C		PT521HD
All Models - Exc. 7.5L - Crew Cab					
	4 OSR > 1.063" Brg O.D/3.622"-3.217" Stack-up	B-1	A / B / C		PT534
70-72 All Models - 2 or 3 Joint Driveshaft					
	4 OSR > 1.063" Brg O.D/ 3.217" Stack-up	B-1	A / B / C		PT521HD

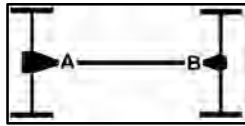

APPLICATION A-1

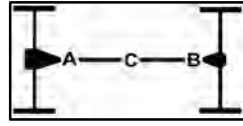

APPLICATION B-1

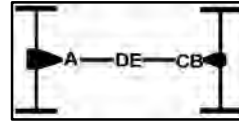

APPLICATION C-1

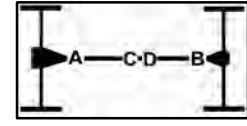

APPLICATION D-1

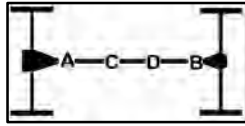

APPLICATION E-1

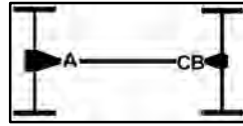

APPLICATION F-1

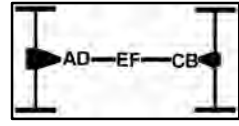

APPLICATION H-1

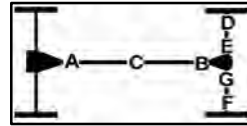

APPLICATION I-1

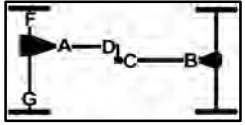

APPLICATION K-1

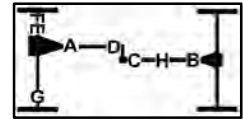

APPLICATION L-1

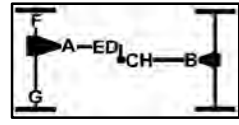

APPLICATION N-1

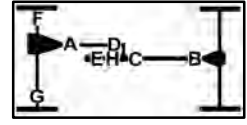

APPLICATION O-1

MAKE/YEARS FITMENT U-JOINT DESCRIPTION LOCATION POSITION PART NO.

FORD

FORD

MAKE/YEARS	FITMENT	U-JOINT DESCRIPTION	LOCATION	POSITION	PART NO.
F100 1/2 TON PICKUP 4WD					
82-83	All Models	2 ISR & 2 OSR > 1.063"/1.125" Brg O.D/ 2.767" ISR	L-1	A / B / C / D	PT1204
		4 OSR > 1.063" Brg O.D/ 3.622" Stack-up	L-1	C / H	PT530
		4 ISR > 1.188" Brg O.D./2.187" Stack-up	L-1	E / F / G	PT297
80-81	All Models - To Serial # GJ0,000	4 OSR > 1.063" Brg O.D/ 3.622" Stack-up	L-1	D	PT530
		2 ISR & 2 OSR > 1.063"/1.125" Brg O.D/ 2.767" ISR	L-1	A	PT1204
	All Models - From Serial # GJ0,000	4 OSR > 1.063" Brg O.D/ 3.622" Stack-up	L-1	A	PT530
		2 ISR & 2 OSR > 1.063"/1.125" Brg O.D/ 2.767" ISR	L-1	D	PT1204
	All Models	4 OSR > 1.063" Brg O.D/ 3.622" Stack-up	L-1	C / H	PT530
		2 ISR & 2 OSR > 1.063"/1.125" Brg O.D/ 2.767" ISR	L-1	B / H	PT1204
		4 ISR > 1.188" Brg O.D./2.187" Stack-up	L-1	E / F / G	PT297
1979	All Models	4 OSR > 1.063" Brg O.D/ 3.622" Stack-up	N-1	A / C / D / E / H	PT530
		2 ISR & 2 OSR > 1.063"/1.125" Brg O.D/ 2.767" ISR	N-1	B	PT1204
		4 ISR > 1.188" Brg O.D./2.187" Stack-up	N-1	F / G	PT297
72-78	All Models - 2 or 3 Joint Driveshaft	4 OSR > 1.063" Brg O.D/ 3.217" Stack-up	N-1	A / D / E	PT521HD
		4 OSR > 1.063" Brg O.D/ 3.217" Stack-up	L-1	B / C / H	PT521HD
		4 ISR > 1.188" Brg O.D./2.187" Stack-up	K-1	F / G	PT297
70-71	All Models - 2 or 3 Joint Driveshaft	4 OSR > 1.063" Brg O.D/ 3.217" Stack-up	N-1	A / D / E	PT521HD
		4 OSR > 1.063" Brg O.D/ 3.217" Stack-up	L-1	B / C / H	PT521HD
		4 ISR > 1.063" Brg O.D/2.183" Stack-up	K-1	F / G	PT260
F150 1/2 TON PICKUP 2WD					
2004	All Models - 2 or 3 Joint Driveshaft	4 OSR > 1.063" Brg O.D/ 3.622" Stack-up	B-1	A / B / C	PT530
		4 OSR > 1.188" Brg O.D./3.622" Stack-up	B-1	A / B / C	PT578
97-03	All Models - 2 or 3 Joint Driveshaft - 4.2L & 4.6L	4 OSR > 1.063" Brg O.D/ 3.622" Stack-up	B-1	A / B / C	PT530
	All Models - 2 or 3 Joint Driveshaft - 5.4L	4 OSR > 1.063" Brg O.D/ 3.622" Stack-up	B-1	A / B / C	PT530
		4 OSR > 1.188" Brg O.D./3.622" Stack-up	B-1	A / B / C	PT578
92-96	All Models - 2 Joint Driveshaft - Exc. Super Cab	4 OSR > 1.063" Brg O.D/ 3.622" Stack-up	A-1	A / B	PT530
	All Models - 3 Joint Driveshaft - Exc. Super Cab	4 OSR > 1.063" Brg O.D/ 3.622" Stack-up	B-1	A / B / C	PT530
		2 ISR & 2 OSR > 1.063"/1.125" Brg O.D/ 2.767" ISR	B-1	A	PT1204
	All Models - 3 Joint Driveshaft - Super Cab	4 OSR > 1.063" Brg O.D/ 3.622" Stack-up	B-1	A / B / C	PT530

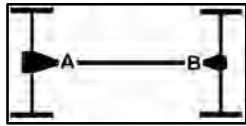

APPLICATION A-1

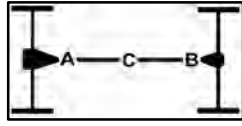

APPLICATION B-1

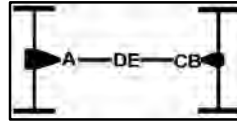

APPLICATION C-1

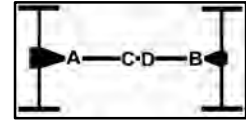

APPLICATION D-1

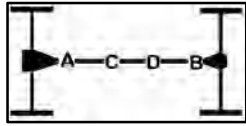

APPLICATION E-1

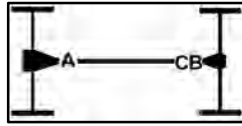

APPLICATION F-1

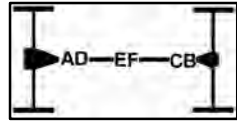

APPLICATION H-1

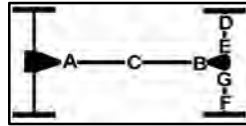

APPLICATION I-1

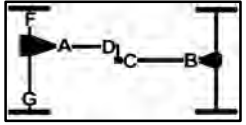

APPLICATION K-1

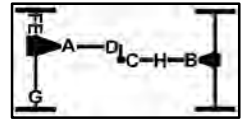

APPLICATION L-1

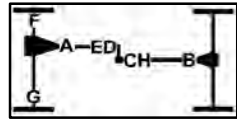

APPLICATION N-1



APPLICATION O-1

MAKE/YEARS FITMENT U-JOINT DESCRIPTION LOCATION POSITION PART NO.

FORD

FORD

F150 1/2 TON PICKUP 2WD

90-91	All Models - 2 Joint Driveshaft - Exc. Super Cab	4 OSR > 1.063" Brg O.D/ 3.622" Stack-up	A-1	A	PT530
		2 ISR & 2 OSR > 1.063"/1.125" Brg O.D/ 2.767" ISR	A-1	B	PT1204
	All Models - 3 Joint Driveshaft - Exc. Super Cab	4 OSR > 1.063" Brg O.D/ 3.622" Stack-up	B-1	A / B / C	PT530
		2 ISR & 2 OSR > 1.063"/1.125" Brg O.D/ 2.767" ISR	B-1	A	PT1204
	All Models - 3 Joint Driveshaft - Super Cab	4 OSR > 1.063" Brg O.D/ 3.622" Stack-up	B-1	A / B / C	PT530
1989	All Models - Regular Cab - 2 Joint Driveshaft - 4.9L 6 Cyl. 3 Spd. A/T	4 OSR > 1.063" Brg O.D/ 3.622" Stack-up	A-1	A / B	PT530
	All Models - Regular Cab - 2 Joint Driveshaft - Exc. 4.9L 6 Cyl. 3 Spd. A/T	4 OSR > 1.063" Brg O.D/ 3.622" Stack-up	A-1	A	PT530
		2 ISR & 2 OSR > 1.063"/1.125" Brg O.D/ 2.767" ISR	A-1	B	PT1204
	All Models - Regular Cab - 3 Joint Driveshaft	4 OSR > 1.063" Brg O.D/ 3.622" Stack-up	B-1	A / C	PT530
		2 ISR & 2 OSR > 1.063"/1.125" Brg O.D/ 2.767" ISR	B-1	B / C	PT1204
	All Models - Exc. Regular Cab	4 OSR > 1.063" Brg O.D/ 3.622" Stack-up	B-1	A / C	PT530
		2 ISR & 2 OSR > 1.063"/1.125" Brg O.D/ 2.767" ISR	B-1	B	PT1204
87-88	All Models - 2 or 3 Joint Driveshaft	4 OSR > 1.063" Brg O.D/ 3.622" Stack-up	B-1	A / C	PT530
		2 ISR & 2 OSR > 1.063"/1.125" Brg O.D/ 2.767" ISR	B-1	B / C	PT1204
79-86	All Models - 2 Joint Driveshaft	4 OSR > 1.063" Brg O.D/ 3.622" Stack-up	A-1	A	PT530
		2 ISR & 2 OSR > 1.063"/1.125" Brg O.D/ 2.767" ISR	A-1	B	PT1204
		4 OSR > 1.063" Brg O.D/ 3.217" Stack-up	A-1	A / B	PT521HD
		4 ISR > 1.125" Brg O.D./2.555 Stack-up	A-1	A / B	PT3105
	All Models - 3 Joint Driveshaft	4 OSR > 1.063" Brg O.D/ 3.622" Stack-up	B-1	A / C	PT530
		2 ISR & 2 OSR > 1.063"/1.125" Brg O.D/ 2.767" ISR	B-1	A / B	PT1204
77-78	All Models - 7.5L A/T	4 OSR > 1.063" Brg O.D/ 3.622" Stack-up	B-1	A / B / C	PT530
		4 OSR > 1.063" Brg O.D/3.622"-3.217" Stack-up	B-1	B / C	PT534
	All Models - 6.6L A/T	4 OSR > 1.063" Brg O.D/ 3.622" Stack-up	B-1	A / B / C	PT530
		4 OSR > 1.063" Brg O.D/3.622"-3.217" Stack-up	B-1	A	PT534
	All Models - Exc. 6.6L A/T & 7.5L A/T	4 OSR > 1.063" Brg O.D/ 3.217" Stack-up	B-1	A / B / C	PT521HD
		4 OSR > 1.063" Brg O.D/3.622"-3.217" Stack-up	B-1	A / B / C	PT534

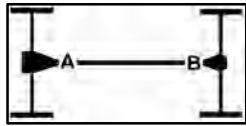

APPLICATION A-1

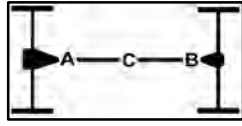

APPLICATION B-1

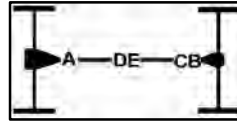

APPLICATION C-1

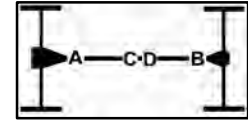

APPLICATION D-1

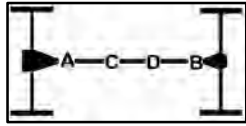

APPLICATION E-1

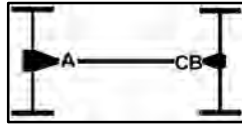

APPLICATION F-1

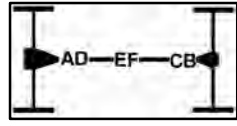

APPLICATION H-1

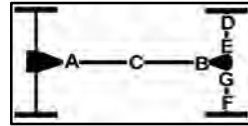

APPLICATION I-1

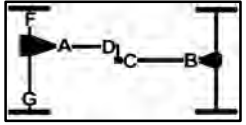

APPLICATION K-1

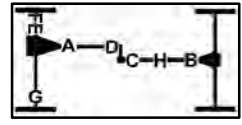

APPLICATION L-1

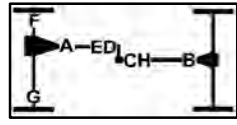

APPLICATION N-1

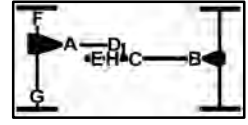

APPLICATION O-1

MAKE/YEARS FITMENT U-JOINT DESCRIPTION LOCATION POSITION PART NO.

FORD

FORD

F150 1/2 TON PICKUP 2WD

1976	All Models - 7.5L A/T - Regular Cab	4 OSR > 1.063" Brg O.D/ 3.622" Stack-up	B-1	A / B / C	PT530
	All Models - 7.5L A/T - Exc. Regular Cab	4 OSR > 1.063" Brg O.D/ 3.622" Stack-up	B-1	A	PT530
		4 OSR > 1.063" Brg O.D/3.622"-3.217" Stack-up	B-1	B / C	PT534
		4 OSR > 1.063" Brg O.D/ 3.217" Stack-up	B-1	B / C	PT521HD
	All Models - Exc. 7.5L A/T	4 OSR > 1.063" Brg O.D/ 3.217" Stack-up	B-1	A / B / C	PT521HD
		4 OSR > 1.063" Brg O.D/3.622"-3.217" Stack-up	B-1	A / B / C	PT534
1975	All Models - 7.5L A/T - Regular Cab	4 OSR > 1.063" Brg O.D/ 3.622" Stack-up	B-1	A / B / C	PT530
	All Models - 7.5L A/T - Exc. Regular Cab	4 OSR > 1.063" Brg O.D/ 3.622" Stack-up	B-1	A	PT530
		4 OSR > 1.063" Brg O.D/3.622"-3.217" Stack-up	B-1	B / C	PT534
	All Models - Exc. 7.5L A/T	4 OSR > 1.063" Brg O.D/ 3.217" Stack-up	B-1	A / B / C	PT521HD
		4 OSR > 1.063" Brg O.D/3.622"-3.217" Stack-up	B-1	A / B / C	PT534

F150 1/2 TON PICKUP 4WD

97-04	All Models	4 OSR > 1.063" Brg O.D/ 3.622" Stack-up	L-1	A / B / C / D	PT530
		4 OSR > 1.188" Brg O.D./3.622" Stack-up	L-1	B / C	PT578
92-96	All Models	2 ISR & 2 OSR > 1.063"/1.125" Brg O.D/ 2.767" ISR	L-1	A / B / C / D	PT1204
		4 OSR > 1.063" Brg O.D/ 3.622" Stack-up	L-1	B / C / H	PT530
		4 ISR > 1.188" Brg O.D./2.187" Stack-up	L-1	E / F / G	PT297
1991	All Models	2 ISR & 2 OSR > 1.063"/1.125" Brg O.D/ 2.767" ISR	L-1	A / B / D	PT1204
		4 OSR > 1.063" Brg O.D/ 3.622" Stack-up	L-1	B / C / H	PT530
		4 ISR > 1.188" Brg O.D./2.187" Stack-up	L-1	E / F / G	PT297
1990	All Models	2 ISR & 2 OSR > 1.063"/1.125" Brg O.D/ 2.767" ISR	L-1	A / B / D	PT1204
		4 OSR > 1.063" Brg O.D/ 3.622" Stack-up	L-1	C / H	PT530
		4 ISR > 1.188" Brg O.D./2.187" Stack-up	L-1	E / F / G	PT297
88-89	All Models	2 ISR & 2 OSR > 1.063"/1.125" Brg O.D/ 2.767" ISR	L-1	A / D	PT1204
		All Models - 2 Joint Driveshaft			
		2 ISR & 2 OSR > 1.063"/1.125" Brg O.D/ 2.767" ISR	L-1	B / C	PT1204
		4 OSR > 1.063" Brg O.D/ 3.622" Stack-up	L-1	B / C	PT530
	All Models - 3 Joint Driveshaft				
		2 ISR & 2 OSR > 1.063"/1.125" Brg O.D/ 2.767" ISR	L-1	B	PT1204
	4 OSR > 1.063" Brg O.D/ 3.622" Stack-up	L-1	C / H	PT530	

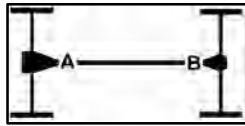

APPLICATION A-1

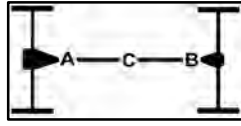

APPLICATION B-1

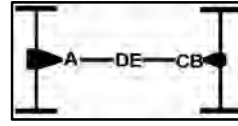

APPLICATION C-1

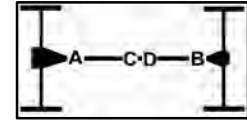

APPLICATION D-1

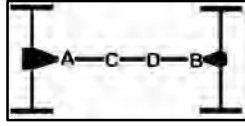

APPLICATION E-1

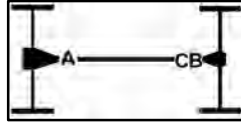

APPLICATION F-1

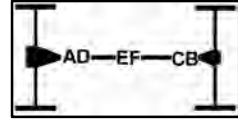

APPLICATION H-1

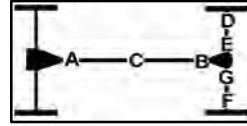

APPLICATION I-1

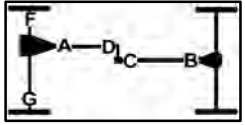

APPLICATION K-1

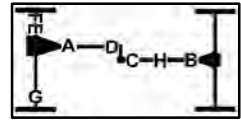

APPLICATION L-1

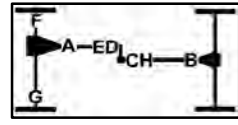

APPLICATION N-1

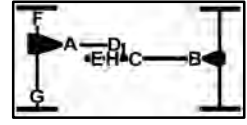

APPLICATION O-1

MAKE/YEARS FITMENT U-JOINT DESCRIPTION LOCATION POSITION PART NO.

FORD

FORD

F150 1/2 TON PICKUP 4WD

88-89 All Models	4 ISR > 1.188" Brg O.D./2.187" Stack-up	L-1	E / F / G	PT297
86-87 All Models	2 ISR & 2 OSR > 1.063"/1.125" Brg O.D/ 2.767" ISR	L-1	A	PT1204
	4 OSR > 1.063" Brg O.D/ 3.622" Stack-up	L-1	D	PT530
All Models - 2 Joint Driveshaft	2 ISR & 2 OSR > 1.063"/1.125" Brg O.D/ 2.767" ISR	L-1	B	PT1204
	4 OSR > 1.063" Brg O.D/ 3.622" Stack-up	L-1	C	PT530
All Models - 3 Joint Driveshaft	2 ISR & 2 OSR > 1.063"/1.125" Brg O.D/ 2.767" ISR	L-1	B / H	PT1204
	4 OSR > 1.063" Brg O.D/ 3.622" Stack-up	L-1	C / H	PT530
All Models	4 ISR > 1.188" Brg O.D./2.187" Stack-up	L-1	E / F / G	PT297
1985 All Models	2 ISR & 2 OSR > 1.063"/1.125" Brg O.D/ 2.767" ISR	L-1	A / D	PT1204
All Models - Crew Cab	2 ISR & 2 OSR > 1.063"/1.125" Brg O.D/ 2.767" ISR	L-1	B / C	PT1204
	4 OSR > 1.063" Brg O.D/ 3.622" Stack-up	L-1	H	PT530
All Models - Exc. Crew Cab	2 ISR & 2 OSR > 1.063"/1.125" Brg O.D/ 2.767" ISR	L-1	B / C	PT1204
	4 OSR > 1.063" Brg O.D/ 3.622" Stack-up	L-1	C	PT530
All Models	4 ISR > 1.188" Brg O.D./2.187" Stack-up	L-1	E / F / G	PT297
82-84 All Models	2 ISR & 2 OSR > 1.063"/1.125" Brg O.D/ 2.767" ISR	L-1	A / B / C / D	PT1204
	4 OSR > 1.063" Brg O.D/ 3.622" Stack-up	L-1	C / H	PT530
	4 ISR > 1.188" Brg O.D./2.187" Stack-up	L-1	E / F / G	PT297
80-81 All Models - To Serial # GJ0,000	4 OSR > 1.063" Brg O.D/ 3.622" Stack-up	L-1	D	PT530
	2 ISR & 2 OSR > 1.063"/1.125" Brg O.D/ 2.767" ISR	L-1	A	PT1204
All Models - From Serial # GJ0,000	4 OSR > 1.063" Brg O.D/ 3.622" Stack-up	L-1	A	PT530
	2 ISR & 2 OSR > 1.063"/1.125" Brg O.D/ 2.767" ISR	L-1	D	PT1204
All Models	4 OSR > 1.063" Brg O.D/ 3.622" Stack-up	L-1	C / H	PT530
	2 ISR & 2 OSR > 1.063"/1.125" Brg O.D/ 2.767" ISR	L-1	B / H	PT1204
	4 ISR > 1.188" Brg O.D./2.187" Stack-up	L-1	E / F / G	PT297
1979 All Models	4 OSR > 1.063" Brg O.D/ 3.622" Stack-up	N-1	A / C / D / E / H	PT530
	2 ISR & 2 OSR > 1.063"/1.125" Brg O.D/ 2.767" ISR	N-1	B	PT1204
	4 ISR > 1.188" Brg O.D./2.187" Stack-up	N-1	F / G	PT297

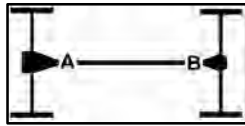

APPLICATION A-1

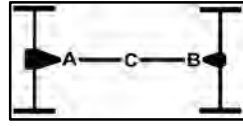

APPLICATION B-1

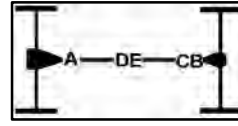

APPLICATION C-1

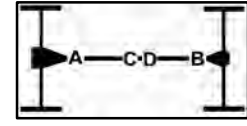

APPLICATION D-1

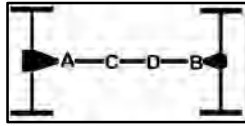

APPLICATION E-1

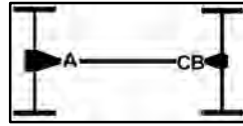

APPLICATION F-1

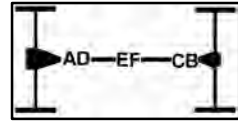

APPLICATION H-1

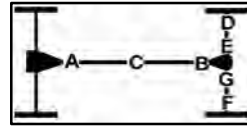

APPLICATION I-1

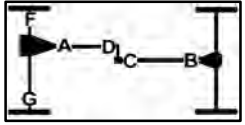

APPLICATION K-1

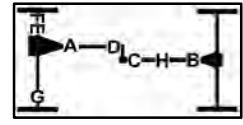

APPLICATION L-1

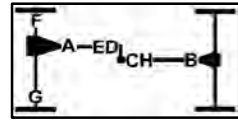

APPLICATION N-1

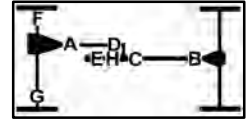

APPLICATION O-1

MAKE/YEARS	FITMENT	U-JOINT DESCRIPTION	LOCATION	POSITION	PART NO.
------------	---------	---------------------	----------	----------	----------

FORD**FORD****F150 1/2 TON PICKUP 4WD****75-78 All Models - Part Time Transfer Case**

4 OSR > 1.063" Brg O.D/ 3.217" Stack-up	N-1	A / D	PT521HD
4 OSR > 1.063" Brg O.D/ 3.622" Stack-up	N-1	A / B / C / D	PT530

All Models - Full Time Transfer Case

4 OSR > 1.063" Brg O.D/ 3.217" Stack-up	N-1	A / B / C / D / E	PT521HD
4 OSR > 1.063" Brg O.D/ 3.622" Stack-up	N-1	A / B / C	PT530

All Models

4 ISR > 1.188" Brg O.D./2.187" Stack-up	N-1	F / G	PT297
---	-----	-------	-------

F250 3/4 TON PICKUP 2WD**98-99 All Models - 2 or 3 Joint Driveshaft**

4 OSR > 1.188" Brg O.D./3.622" Stack-up	B-1	A / B / C	PT578
---	-----	-----------	-------

1997 All Models - 5.8L A/T - Regular Cab

4 OSR > 1.063" Brg O.D/ 3.622" Stack-up	A-1	A	PT530
2 ISR & 2 OSR > 1.063"/1.125" Brg O.D/ 2.767" ISR	A-1	B	PT1204

All Models - 5.8L M/T - Regular Cab

4 OSR > 1.063" Brg O.D/ 3.622" Stack-up	B-1	C	PT530
2 ISR & 2 OSR > 1.063"/1.125" Brg O.D/ 2.767" ISR	B-1	A / B	PT1204

All Models - 5.8L - Crew Cab

4 OSR > 1.188" Brg O.D./3.622" Stack-up	B-1	A / B / C	PT578
---	-----	-----------	-------

All Models - 5.8L - Super Cab - Short Bed

4 OSR > 1.188" Brg O.D./3.622" Stack-up	B-1	A / B / C	PT578
---	-----	-----------	-------

All Models - 5.8L A/T - Super Cab - Long Bed

4 OSR > 1.063" Brg O.D/ 3.622" Stack-up	B-1	A / C	PT530
2 ISR & 2 OSR > 1.063"/1.125" Brg O.D/ 2.767" ISR	B-1	B	PT1204

All Models - 5.8L M/T - Super Cab - Long Bed

4 OSR > 1.063" Brg O.D/ 3.622" Stack-up	B-1	C	PT530
2 ISR & 2 OSR > 1.063"/1.125" Brg O.D/ 2.767" ISR	B-1	A / B	PT1204

All Models - EXC. 5.8L - 2 or 3 Joint Driveshaft

4 OSR > 1.188" Brg O.D./3.622" Stack-up	B-1	A / B / C	PT578
---	-----	-----------	-------

95-96 All Models - 4.9L or 5.8L - 2 or 3 Joint Driveshaft

4 OSR > 1.063" Brg O.D/ 3.622" Stack-up	B-1	A / C	PT530
2 ISR & 2 OSR > 1.063"/1.125" Brg O.D/ 2.767" ISR	B-1	B	PT1204

All Models - 7.3L Dsl or 7.5L - 2 or 3 Joint Driveshaft

4 OSR > 1.188" Brg O.D./3.622" Stack-up	B-1	A / B / C	PT578
---	-----	-----------	-------

90-94 All Models - 2 Joint Driveshaft

4 OSR > 1.063" Brg O.D/ 3.622" Stack-up	A-1	A	PT530
2 ISR & 2 OSR > 1.063"/1.125" Brg O.D/ 2.767" ISR	A-1	B	PT1204

All Models - 3 Joint Driveshaft - 4.9L

4 OSR > 1.063" Brg O.D/ 3.622" Stack-up	B-1	A / B / C	PT530
2 ISR & 2 OSR > 1.063"/1.125" Brg O.D/ 2.767" ISR	B-1	C	PT1204

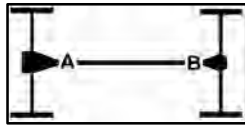

APPLICATION A-1

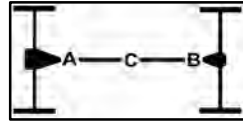

APPLICATION B-1

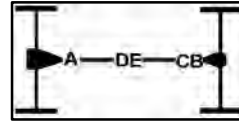

APPLICATION C-1

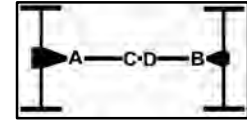

APPLICATION D-1

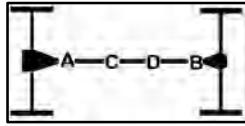

APPLICATION E-1

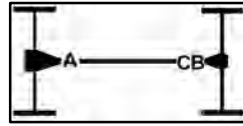

APPLICATION F-1

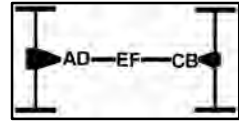

APPLICATION H-1

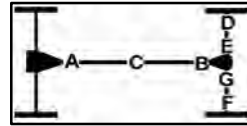

APPLICATION I-1

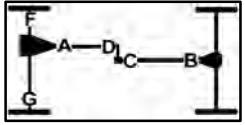

APPLICATION K-1

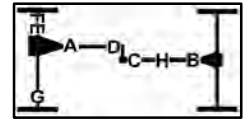

APPLICATION L-1

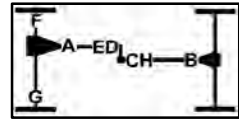

APPLICATION N-1

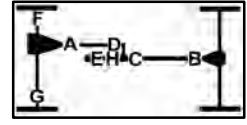

APPLICATION O-1

MAKE/YEARS FITMENT U-JOINT DESCRIPTION LOCATION POSITION PART NO.

FORD

FORD

F250 3/4 TON PICKUP 2WD

90-94 All Models - 3 Joint Driveshaft - 5.0L	4 OSR > 1.063" Brg O.D/ 3.622" Stack-up	B-1	A / C	PT530	
	2 ISR & 2 OSR > 1.063"/1.125" Brg O.D/ 2.767" ISR	B-1	B	PT1204	
	All Models - 3 Joint Driveshaft - 5.8L - 3 Spd. A/T				
	4 OSR > 1.063" Brg O.D/ 3.622" Stack-up	B-1	A / C	PT530	
	2 ISR & 2 OSR > 1.063"/1.125" Brg O.D/ 2.767" ISR	B-1	B	PT1204	
	4 OSR > 1.188" Brg O.D./3.622" Stack-up	B-1	A / B / C	PT578	
	All Models - 3 Joint Driveshaft - 5.8L - 4 Spd. A/T				
	4 OSR > 1.188" Brg O.D./3.622" Stack-up	B-1	A / B / C	PT578	
	All Models - 3 Joint Driveshaft - 5.8L - M/T				
	4 OSR > 1.063" Brg O.D/ 3.622" Stack-up	B-1	A / B	PT530	
	2 ISR & 2 OSR > 1.063"/1.125" Brg O.D/ 2.767" ISR	B-1	C	PT1204	
	All Models - 3 Joint Driveshaft - 7.3L Dsl or 7.5L				
4 OSR > 1.188" Brg O.D./3.622" Stack-up	B-1	A / B / C	PT578		
88-89 All Models - 2 Joint Driveshaft	4 OSR > 1.063" Brg O.D/ 3.622" Stack-up	A-1	A	PT530	
	2 ISR & 2 OSR > 1.063"/1.125" Brg O.D/ 2.767" ISR	A-1	B	PT1204	
	4 OSR > 1.188" Brg O.D./3.622" Stack-up	A-1	A / B	PT578	
	All Models - 3 Joint Driveshaft				
	4 OSR > 1.063" Brg O.D/ 3.622" Stack-up	B-1	A / C	PT530	
	2 ISR & 2 OSR > 1.063"/1.125" Brg O.D/ 2.767" ISR	B-1	A / B / C	PT1204	
1987 All Models - Regular Cab - 5 Spd. M/T	4 OSR > 1.188" Brg O.D./3.622" Stack-up	A-1	A / B	PT578	
	All Models - Regular Cab - Exc. 5 Spd. M/T				
	4 OSR > 1.063" Brg O.D/ 3.622" Stack-up	A-1	A	PT530	
	2 ISR & 2 OSR > 1.063"/1.125" Brg O.D/ 2.767" ISR	A-1	B	PT1204	
	All Models - Crew Cab				
	4 OSR > 1.063" Brg O.D/ 3.622" Stack-up	B-1	A / C	PT530	
	2 ISR & 2 OSR > 1.063"/1.125" Brg O.D/ 2.767" ISR	B-1	A / B	PT1204	
	All Models - Super Cab - 5 Spd. M/T				
	4 OSR > 1.188" Brg O.D./3.622" Stack-up	A-1	A / B	PT578	
	All Models - Super Cab - Exc. 5 Spd. M/T				
	4 OSR > 1.063" Brg O.D/ 3.622" Stack-up	A-1	A	PT530	
	2 ISR & 2 OSR > 1.063"/1.125" Brg O.D/ 2.767" ISR	A-1	B	PT1204	
80-86 All Models - 2 or 3 Joint Driveshaft	4 OSR > 1.063" Brg O.D/ 3.622" Stack-up	B-1	A / C	PT530	
	2 ISR & 2 OSR > 1.063"/1.125" Brg O.D/ 2.767" ISR	B-1	A / B / C	PT1204	

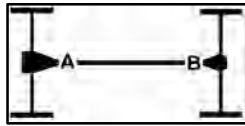

APPLICATION A-1

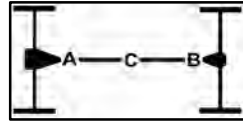

APPLICATION B-1

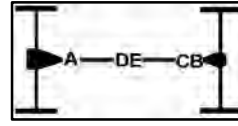

APPLICATION C-1

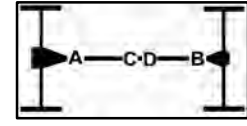

APPLICATION D-1

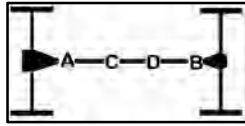

APPLICATION E-1

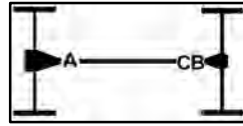

APPLICATION F-1

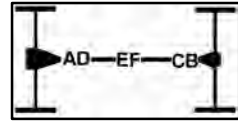

APPLICATION H-1

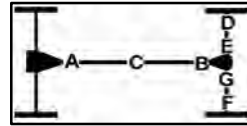

APPLICATION I-1

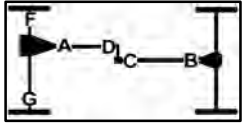

APPLICATION K-1

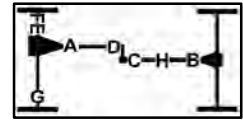

APPLICATION L-1

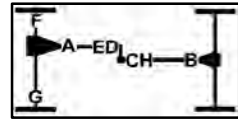

APPLICATION N-1

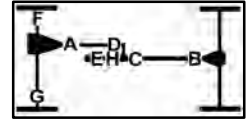

APPLICATION O-1

MAKE/YEARS FITMENT U-JOINT DESCRIPTION LOCATION POSITION PART NO.

FORD

FORD

MAKE/YEARS	FITMENT	U-JOINT DESCRIPTION	LOCATION	POSITION	PART NO.
F250 3/4 TON PICKUP 2WD					
1979	All Models - 6.6L V8	4 OSR > 1.188" Brg O.D./3.622" Stack-up	B-1	A / B / C	PT578
	All Models - Exc. 6.6L V8 - 133", 138" or 155" Wheel Base	4 OSR > 1.063" Brg O.D./ 3.622" Stack-up	B-1	A / C	PT530
		4 OSR > 1.188" Brg O.D./3.622" Stack-up	B-1	B	PT578
		2 ISR & 2 OSR > 1.063"/1.125" Brg O.D/ 2.767" ISR	B-1	B	PT1204
	All Models - Exc. 6.6L V8 - 150" Wheel Base	4 OSR > 1.063" Brg O.D/ 3.622" Stack-up	B-1	A	PT530
		4 OSR > 1.188" Brg O.D./3.622" Stack-up	B-1	B / C	PT578
1978	All Models - 4.9L 6 Cyl. & 5.8L V8	4 OSR > 1.063" Brg O.D/ 3.217" Stack-up	B-1	A / B / C	PT521HD
	All Models - 6.6L V8 & 7.5L V8	4 OSR > 1.188" Brg O.D./3.622" Stack-up	B-1	C	PT578
		4 OSR > 1.063" Brg O.D/ 3.622" Stack-up	B-1	A / B / C	PT530
1977	All Models - 4.9L 6 Cyl. & 5.8L V8	4 OSR > 1.063" Brg O.D/ 3.217" Stack-up	B-1	A / B / C	PT521HD
		4 OSR > 1.063" Brg O.D/3.622"-3.217" Stack-up	B-1	A / B / C	PT534
	All Models - Exc. 4.9L 6 Cyl. & 5.8L V8 - 133" or 138" Wheel Base	4 OSR > 1.188" Brg O.D./3.622" Stack-up	B-1	A / B / C	PT578
		4 OSR > 1.063" Brg O.D/ 3.622" Stack-up	B-1	A / C	PT530
	All Models - Exc. 4.9L 6 Cyl. & 5.8L V8 - 150" or 155" Wheel Base	4 OSR > 1.188" Brg O.D./3.622" Stack-up	B-1	A / B / C	PT578
		4 OSR > 1.063" Brg O.D/ 3.622" Stack-up	B-1	A / B / C	PT530
		4 OSR > 1.063" Brg O.D/ 3.217" Stack-up	B-1	A / B / C	PT521HD
75-76	All Models - 6 Cyl. & 5.9L V8	4 OSR > 1.063" Brg O.D/ 3.217" Stack-up	B-1	A / B / C	PT521HD
		4 OSR > 1.063" Brg O.D/3.622"-3.217" Stack-up	B-1	B / C	PT534
	All Models - Exc. 6 Cyl. & 5.9L V8 - 2 Joint Driveshaft	4 OSR > 1.188" Brg O.D./3.622" Stack-up	A-1	A / B	PT578
	All Models - Exc. 6 Cyl. & 5.9L V8 - 3 Joint Driveshaft - 133" & 138" Wheel Base	4 OSR > 1.188" Brg O.D./3.622" Stack-up	B-1	A / B / C	PT578
		4 OSR > 1.063" Brg O.D/ 3.622" Stack-up	B-1	A / C	PT530
	All Models - Exc. 6 Cyl. & 5.9L V8 - 3 Joint Driveshaft - Exc. 133" & 138" Wheel Base	4 OSR > 1.063" Brg O.D/ 3.217" Stack-up	B-1	A / B / C	PT521HD
		4 OSR > 1.188" Brg O.D./3.622" Stack-up	B-1	A / B / C	PT578
		4 OSR > 1.063" Brg O.D/ 3.622" Stack-up	B-1	A / B / C	PT530
70-74	All Models - 6 Cyl. & 5.9L V8	4 OSR > 1.063" Brg O.D/ 3.217" Stack-up	B-1	A / B / C	PT521HD
	All Models - Exc. 6 Cyl. & 5.9L V8	4 OSR > 1.063" Brg O.D/ 3.622" Stack-up	B-1	A / B / C	PT530

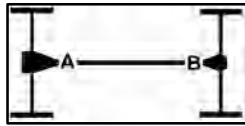

APPLICATION A-1

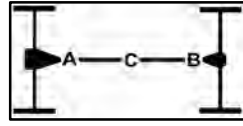

APPLICATION B-1

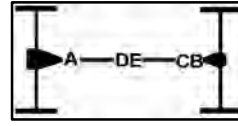

APPLICATION C-1

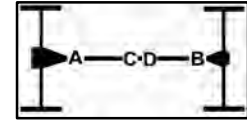

APPLICATION D-1

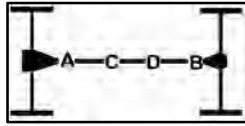

APPLICATION E-1

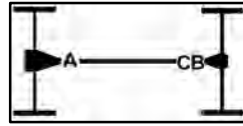

APPLICATION F-1

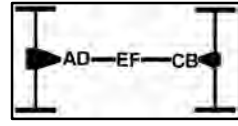

APPLICATION H-1

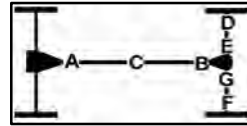

APPLICATION I-1

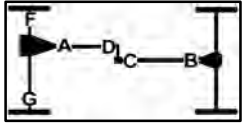

APPLICATION K-1

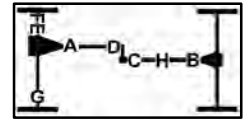

APPLICATION L-1

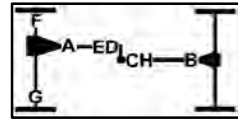

APPLICATION N-1

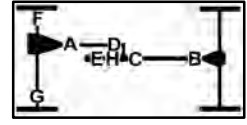

APPLICATION O-1

MAKE/YEARS FITMENT U-JOINT DESCRIPTION LOCATION POSITION PART NO.

FORD

FORD

F250 3/4 TON PICKUP 4WD

1999	All Models - Exc. Super Duty	4 OSR > 1.063" Brg O.D/ 3.622" Stack-up	L-1	A / D	PT530	
		4 OSR > 1.188" Brg O.D./3.622" Stack-up	L-1	B / C / H	PT578	
	All Models - Super Duty	4 OSR > 1.063" Brg O.D/ 3.622" Stack-up	N-1	A / D / E	PT530	
		4 OSR > 1.188" Brg O.D./3.622" Stack-up	N-1	B / C / H	PT578	
		4 OSR > 1.188" Brg O.D./4.182" Stack-up	N-1	B / C / H	PT560	
	All Models	4 ISR > 1.375" Brg O.D./2.995" Stack-up	L-1	F / G	PT332	
	97-98	All Models - Exc. Super Duty	4 OSR > 1.063" Brg O.D/ 3.622" Stack-up	L-1	A / D	PT530
			All Models - Super Duty	2 ISR & 2 OSR > 1.063"/1.125" Brg O.D/ 2.767" ISR	L-1	A / D
		All Models	4 OSR > 1.188" Brg O.D./3.622" Stack-up	L-1	B / C / H	PT578
			4 ISR > 1.188" Brg O.D./2.187" Stack-up	L-1	E / F / G	PT297
4 OSR > 1.188" Brg O.D./3.622" Stack-up			L-1	E / F / G	PT578	
90-96		All Models	2 ISR & 2 OSR > 1.063"/1.125" Brg O.D/ 2.767" ISR	L-1	A / D	PT1204
	All Models - Exc. 7.3L Dsl or 7.5L	4 OSR > 1.063" Brg O.D/ 3.622" Stack-up	L-1	C / H	PT530	
		2 ISR & 2 OSR > 1.063"/1.125" Brg O.D/ 2.767" ISR	L-1	B	PT1204	
	All Models - 7.3L Dsl or 7.5L	4 OSR > 1.188" Brg O.D./3.622" Stack-up	L-1	B / C / H	PT578	
		All Models	4 ISR > 1.188" Brg O.D./2.187" Stack-up	L-1	E / F / G	PT297
		4 OSR > 1.188" Brg O.D./3.622" Stack-up	L-1	E / F / G	PT578	
	88-89	All Models	2 ISR & 2 OSR > 1.063"/1.125" Brg O.D/ 2.767" ISR	L-1	A / D	PT1204
		All Models - Regular Cab or Crew Cab - 4.9L or 5.8L	4 OSR > 1.063" Brg O.D/ 3.622" Stack-up	L-1	C / H	PT530
2 ISR & 2 OSR > 1.063"/1.125" Brg O.D/ 2.767" ISR			L-1	B	PT1204	
All Models - Regular Cab or Crew Cab - 7.3L Dsl or 7.5L		4 OSR > 1.188" Brg O.D./3.622" Stack-up	L-1	B / C / H	PT578	
		All Models	4 ISR > 1.188" Brg O.D./2.187" Stack-up	L-1	E / F / G	PT297
4 OSR > 1.188" Brg O.D./3.622" Stack-up		L-1	E / F / G	PT578		
1987		All Models	2 ISR & 2 OSR > 1.063"/1.125" Brg O.D/ 2.767" ISR	L-1	A	PT1204
	4 OSR > 1.063" Brg O.D/ 3.622" Stack-up		L-1	D	PT530	

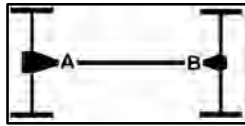

APPLICATION A-1

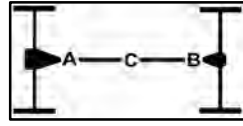

APPLICATION B-1

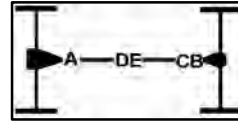

APPLICATION C-1

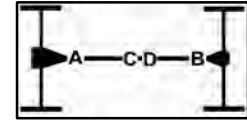

APPLICATION D-1

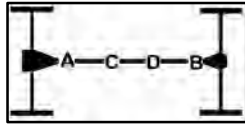

APPLICATION E-1

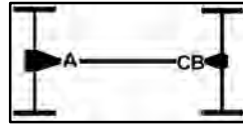

APPLICATION F-1

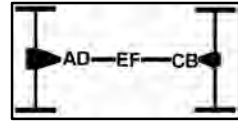

APPLICATION H-1

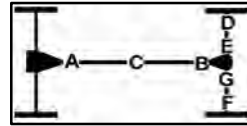

APPLICATION I-1

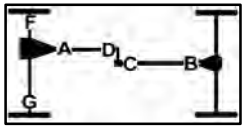

APPLICATION K-1

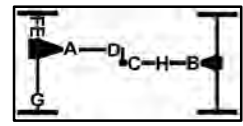

APPLICATION L-1

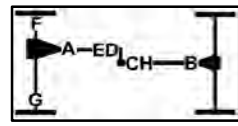

APPLICATION N-1



APPLICATION O-1

MAKE/YEARS FITMENT U-JOINT DESCRIPTION LOCATION POSITION PART NO.

FORD

FORD

F250 3/4 TON PICKUP 4WD

1987 All Models - Regular Cab - 5 Spd M/T	4 OSR > 1.063" Brg O.D/ 3.622" Stack-up	L-1	C	PT530
	2 ISR & 2 OSR > 1.063"/1.125" Brg O.D/ 2.767" ISR	L-1	B	PT1204
All Models - Regular Cab - Exc. 5 Spd M/T	4 OSR > 1.188" Brg O.D./3.622" Stack-up	L-1	B / C	PT578
All Models - Crew Cab	4 OSR > 1.063" Brg O.D/ 3.622" Stack-up	L-1	B / C	PT530
	2 ISR & 2 OSR > 1.063"/1.125" Brg O.D/ 2.767" ISR	L-1	H	PT1204
All Models	4 ISR > 1.188" Brg O.D./2.187" Stack-up	L-1	E / F / G	PT297
	4 OSR > 1.188" Brg O.D./3.622" Stack-up	L-1	E / F / G	PT578
84-86 All Models	2 ISR & 2 OSR > 1.063"/1.125" Brg O.D/ 2.767" ISR	L-1	A / B / C / D	PT1204
	4 OSR > 1.063" Brg O.D/ 3.622" Stack-up	L-1	B / H	PT530
	4 ISR > 1.188" Brg O.D./2.187" Stack-up	L-1	E / F / G	PT297
	4 OSR > 1.188" Brg O.D./3.622" Stack-up	L-1	E / F / G	PT578
82-83 All Models	4 OSR > 1.063" Brg O.D/ 3.622" Stack-up	L-1	H	PT530
	2 ISR & 2 OSR > 1.063"/1.125" Brg O.D/ 2.767" ISR	L-1	A / B / C / D	PT1204
	4 ISR > 1.188" Brg O.D./2.187" Stack-up	L-1	E / F / G	PT297
	4 OSR > 1.188" Brg O.D./3.622" Stack-up	L-1	E / F / G	PT578
80-81 All Models	4 OSR > 1.063" Brg O.D/ 3.622" Stack-up	L-1	A / C / D / H	PT530
	2 ISR & 2 OSR > 1.063"/1.125" Brg O.D/ 2.767" ISR	L-1	A / B / D / H	PT1204
	4 ISR > 1.188" Brg O.D./2.187" Stack-up	L-1	E / F / G	PT297
	4 OSR > 1.188" Brg O.D./3.622" Stack-up	L-1	E / F / G	PT578
1979 All Models	4 OSR > 1.063" Brg O.D/ 3.622" Stack-up	N-1	C / D / E / H	PT530
	2 ISR & 2 OSR > 1.063"/1.125" Brg O.D/ 2.767" ISR	N-1	A / B	PT1204
	4 ISR > 1.188" Brg O.D./2.187" Stack-up	N-1	F / G	PT297
	4 ISR > 1.375" Brg O.D./2.995" Stack-up	N-1	F / G	PT332
1978 All Models - Full Time Transfer Case	4 OSR > 1.063" Brg O.D/ 3.217" Stack-up	O-1	A / B / C / D	PT521HD
	4 OSR > 1.063" Brg O.D/3.622"-3.217" Stack-up	O-1	E / H	PT534
	4 OSR > 1.063" Brg O.D/ 3.622" Stack-up	O-1	E / H	PT530
	4 ISR > 1.188" Brg O.D./2.187" Stack-up	O-1	F / G	PT297
	4 OSR > 1.188" Brg O.D./3.622" Stack-up	O-1	F / G	PT578

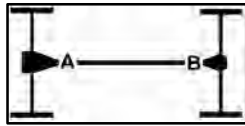

APPLICATION A-1

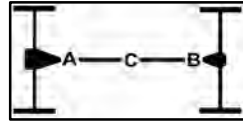

APPLICATION B-1

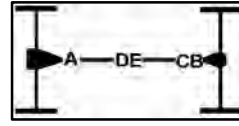

APPLICATION C-1

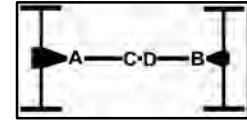

APPLICATION D-1

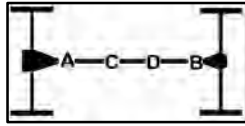

APPLICATION E-1

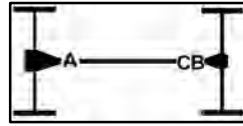

APPLICATION F-1

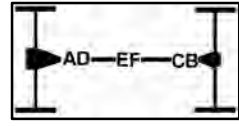

APPLICATION H-1

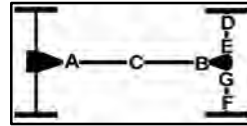

APPLICATION I-1

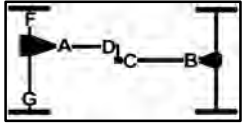

APPLICATION K-1

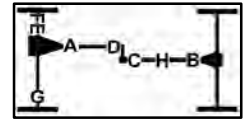

APPLICATION L-1

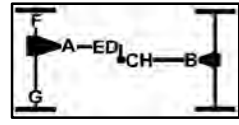

APPLICATION N-1

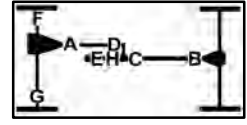

APPLICATION O-1

MAKE/YEARS FITMENT U-JOINT DESCRIPTION LOCATION POSITION PART NO.

FORD

FORD

MAKE/YEARS	FITMENT	U-JOINT DESCRIPTION	LOCATION	POSITION	PART NO.
F250 3/4 TON PICKUP 4WD					
1978	All Models	Part Time Transfer Case			
		4 OSR > 1.063" Brg O.D/ 3.217" Stack-up	O-1	D	PT521HD
		4 OSR > 1.063" Brg O.D/ 3.622" Stack-up	O-1	A / B / C	PT530
		4 OSR > 1.063" Brg O.D/ 3.217" Stack-up	O-1	E / H	PT521HD
		4 OSR > 1.063" Brg O.D/ 3.622" Stack-up	O-1	E / H	PT530
		4 ISR > 1.188" Brg O.D./2.187" Stack-up	O-1	F / G	PT297
		4 ISR > 1.375" Brg O.D./2.995" Stack-up	O-1	F / G	PT332
1977	All Models	Full Time Transfer Case			
		4 OSR > 1.063" Brg O.D/ 3.217" Stack-up	O-1	A / B / C / D	PT521HD
		Part Time Transfer Case			
		4 OSR > 1.063" Brg O.D/3.622"-3.217" Stack-up	O-1	A / B / C / D	PT534
		All Models			
		4 OSR > 1.063" Brg O.D/3.622"-3.217" Stack-up	O-1	E / H	PT534
		4 OSR > 1.063" Brg O.D/ 3.622" Stack-up	O-1	E / H	PT530
		4 ISR > 1.188" Brg O.D./2.187" Stack-up	O-1	F / G	PT297
		4 OSR > 1.188" Brg O.D./3.622" Stack-up	O-1	F / G	PT578
75-76	All Models	Full Time Transfer Case			
		4 OSR > 1.063" Brg O.D/ 3.217" Stack-up	O-1	A / B / C / D	PT521HD
		4 OSR > 1.063" Brg O.D/3.622"-3.217" Stack-up	O-1	E / H	PT534
		4 ISR > 1.188" Brg O.D./2.187" Stack-up	O-1	F / G	PT297
		4 OSR > 1.188" Brg O.D./3.622" Stack-up	O-1	F / G	PT578
		Part Time Transfer Case			
		4 OSR > 1.063" Brg O.D/ 3.217" Stack-up	O-1	B / C	PT521HD
		4 OSR > 1.063" Brg O.D/3.622"-3.217" Stack-up	O-1	A / B / C / D	PT534
		4 OSR > 1.063" Brg O.D/3.622"-3.217" Stack-up	O-1	E / H	PT534
		4 OSR > 1.063" Brg O.D/ 3.217" Stack-up	O-1	E / H	PT521HD
		4 ISR > 1.188" Brg O.D./2.187" Stack-up	O-1	F / G	PT297
		4 OSR > 1.188" Brg O.D./3.622" Stack-up	O-1	F / G	PT578
70-74	All Models				
		4 OSR > 1.063" Brg O.D/ 3.217" Stack-up	O-1	E / H	PT521HD
		4 OSR > 1.063" Brg O.D/3.622"-3.217" Stack-up	O-1	A / B / C / D	PT534
		4 ISR > 1.063" Brg O.D/2.183" Stack-up	O-1	F / G	PT260
		4 OSR > 1.188" Brg O.D./3.622" Stack-up	O-1	F / G	PT578
F250 SUPER DUTY 3/4 TON PICKUP 2WD					
99-06	All Models				
		4 OSR > 1.188" Brg O.D./4.182" Stack-up	B-1	A / B / C	PT560
F250 SUPER DUTY 3/4 TON PICKUP 4WD					
05-06	All Models				
		4 OSR > 1.188" Brg O.D./3.622" Stack-up	N-1	A / D / E	PT578
		4 OSR > 1.188" Brg O.D./4.182" Stack-up	N-1	B / C / H	PT560
		4 ISR > 1.375" Brg O.D./2.995" Stack-up	N-1	F / G	PT332

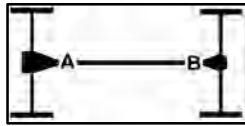

APPLICATION A-1

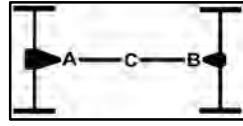

APPLICATION B-1

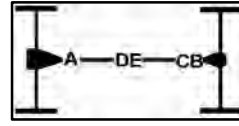

APPLICATION C-1

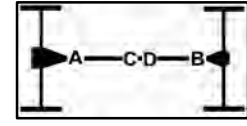

APPLICATION D-1

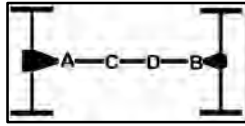

APPLICATION E-1

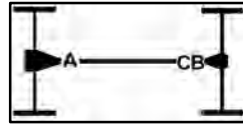

APPLICATION F-1

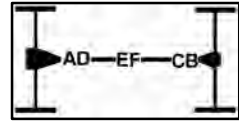

APPLICATION H-1

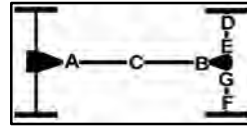

APPLICATION I-1

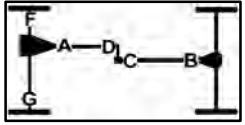

APPLICATION K-1

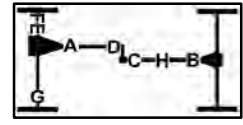

APPLICATION L-1

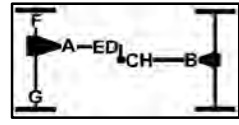

APPLICATION N-1

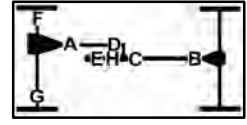

APPLICATION O-1

MAKE/YEARS FITMENT U-JOINT DESCRIPTION LOCATION POSITION PART NO.

FORD

FORD

MAKE/YEARS	FITMENT	U-JOINT DESCRIPTION	LOCATION	POSITION	PART NO.
F250 SUPER DUTY 3/4 TON PICKUP 4WD					
99-04	All Models	4 OSR > 1.188" Brg O.D./3.622" Stack-up	N-1	A / D / E	PT578
	All Models - Regular Cab	4 OSR > 1.188" Brg O.D./3.622" Stack-up	N-1	C / H	PT578
		4 OSR > 1.188" Brg O.D./4.182" Stack-up	N-1	B	PT560
	All Models - Super Cab or Crew Cab	4 OSR > 1.188" Brg O.D./4.182" Stack-up	N-1	B / C / H	PT560
	All Models	4 ISR > 1.375" Brg O.D./2.995" Stack-up	N-1	F / G	PT332
F350 1 TON PICKUP 2WD					
95-97	All Models - 2 or 3 Joint Drive Shaft - 4.9L	4 OSR > 1.063" Brg O.D./ 3.622" Stack-up	B-1	A / C	PT530
		2 ISR & 2 OSR > 1.063"/1.125" Brg O.D/ 2.767" ISR	B-1	B	PT1204
	All Models - 2 or 3 Joint Drive Shaft - 5.8L	4 OSR > 1.063" Brg O.D/ 3.622" Stack-up	B-1	A / C	PT530
		2 ISR & 2 OSR > 1.063"/1.125" Brg O.D/ 2.767" ISR	B-1	B	PT1204
		4 OSR > 1.188" Brg O.D./3.622" Stack-up	B-1	A / B / C	PT578
	All Models - 2 or 3 Joint Drive Shaft - 7.3L Dsl or 7.5L	4 OSR > 1.188" Brg O.D./3.622" Stack-up	B-1	A / B / C	PT578
92-94	All Models - Regular Cab - 2 or 3 Joint Drive Shaft	4 OSR > 1.063" Brg O.D/ 3.622" Stack-up	B-1	A / C	PT530
		2 ISR & 2 OSR > 1.063"/1.125" Brg O.D/ 2.767" ISR	B-1	A / B / C	PT1204
		4 OSR > 1.188" Brg O.D./3.622" Stack-up	B-1	A / B / C	PT578
	All Models - Chassis Cab	4 OSR > 1.188" Brg O.D./3.622" Stack-up	B-1	A / B / C	PT578
		2 ISR & 2 OSR > 1.063"/1.125" Brg O.D/ 2.767" ISR	B-1	A	PT1204
	All Models - Crew Cab - 5.8L	4 OSR > 1.063" Brg O.D/ 3.622" Stack-up	B-1	A / C	PT530
		2 ISR & 2 OSR > 1.063"/1.125" Brg O.D/ 2.767" ISR	B-1	A / B	PT1204
	All Models - Crew Cab - 7.3L Dsl A/T	4 OSR > 1.063" Brg O.D/ 3.622" Stack-up	B-1	A / C	PT530
		2 ISR & 2 OSR > 1.063"/1.125" Brg O.D/ 2.767" ISR	B-1	B	PT1204
	All Models - Crew Cab - 7.3L Dsl M/T	4 OSR > 1.188" Brg O.D./3.622" Stack-up	B-1	A / B / C	PT578
	All Models - Crew Cab - 7.5L	4 OSR > 1.188" Brg O.D./3.622" Stack-up	B-1	A / B / C	PT578
	All Models - Super Cab	4 OSR > 1.188" Brg O.D./3.622" Stack-up	B-1	A / B / C	PT578

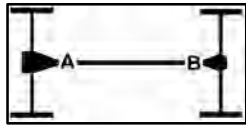

APPLICATION A-1

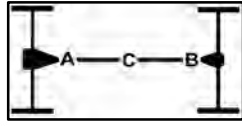

APPLICATION B-1

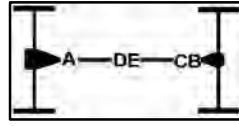

APPLICATION C-1

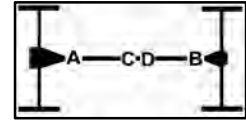

APPLICATION D-1

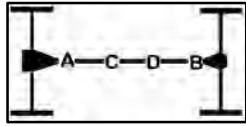

APPLICATION E-1

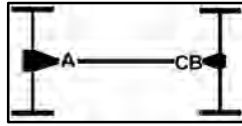

APPLICATION F-1

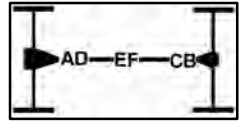

APPLICATION H-1

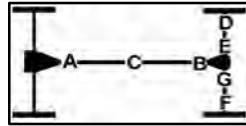

APPLICATION I-1

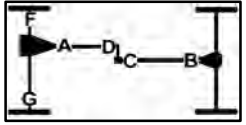

APPLICATION K-1

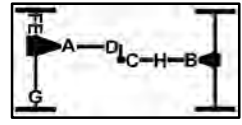

APPLICATION L-1

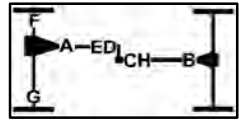

APPLICATION N-1



APPLICATION O-1

MAKE/YEARS FITMENT U-JOINT DESCRIPTION LOCATION POSITION PART NO.

FORD

FORD

F350 1 TON PICKUP 2WD						
1991	All Models - 3 or 4 Spd. A/T - 133" Wheel Base	4 OSR > 1.063" Brg O.D/ 3.622" Stack-up	A-1	A	PT530	
		2 ISR & 2 OSR > 1.063"/1.125" Brg O.D/ 2.767" ISR	A-1	B	PT1204	
	All Models - 3 Spd. A/T - Exc. 133" Wheel Base	4 OSR > 1.188" Brg O.D./3.622" Stack-up	B-1	A / B / C	PT578	
	All Models - 4 Spd. A/T - 136" Wheel Base - 5.8L	2 ISR & 2 OSR > 1.063"/1.125" Brg O.D/ 2.767" ISR	B-1	A	PT1204	
		4 OSR > 1.188" Brg O.D./3.622" Stack-up	B-1	B / C	PT578	
	All Models - 4 Spd. A/T - 136" Wheel Base - Exc. 5.8L	4 OSR > 1.188" Brg O.D./3.622" Stack-up	B-1	A / B / C	PT578	
	All Models - 4 Spd. A/T - 155" or 160" Wheel Base	4 OSR > 1.188" Brg O.D./3.622" Stack-up	B-1	A / B / C	PT578	
	All Models - 4 Spd. A/T - 168" Wheel Base	4 OSR > 1.063" Brg O.D/ 3.622" Stack-up	B-1	A / C	PT530	
		2 ISR & 2 OSR > 1.063"/1.125" Brg O.D/ 2.767" ISR	B-1	B	PT1204	
	All Models - M/T	4 OSR > 1.188" Brg O.D./3.622" Stack-up	B-1	A / B / C	PT578	
		2 ISR & 2 OSR > 1.063"/1.125" Brg O.D/ 2.767" ISR	B-1	A	PT1204	
	1990	All Models - A/T - 133" Wheel Base	4 OSR > 1.063" Brg O.D/ 3.622" Stack-up	A-1	A	PT530
			2 ISR & 2 OSR > 1.063"/1.125" Brg O.D/ 2.767" ISR	A-1	B	PT1204
		All Models - A/T - 136" or 155" Wheel Base	4 OSR > 1.188" Brg O.D./3.622" Stack-up	B-1	A / B / C	PT578
All Models - A/T - 160" Wheel Base - V8 Engines		4 OSR > 1.188" Brg O.D./3.622" Stack-up	B-1	A / B / C	PT578	
All Models - A/T - 160" Wheel Base - Exc. V8 Engines		2 ISR & 2 OSR > 1.063"/1.125" Brg O.D/ 2.767" ISR	B-1	A	PT1204	
		4 OSR > 1.188" Brg O.D./3.622" Stack-up	B-1	B / C	PT578	
All Models - A/T - 168" Wheel Base		4 OSR > 1.063" Brg O.D/ 3.622" Stack-up	B-1	A / C	PT530	
		2 ISR & 2 OSR > 1.063"/1.125" Brg O.D/ 2.767" ISR	B-1	B	PT1204	
All Models - M/T - 133" Wheel Base - 4.9L or 5.8L		4 OSR > 1.063" Brg O.D/ 3.622" Stack-up	B-1	C	PT530	
		2 ISR & 2 OSR > 1.063"/1.125" Brg O.D/ 2.767" ISR	B-1	A / B	PT1204	
All Models - M/T - 136" or 160" Wheel Base - 4.9L or 5.8L		2 ISR & 2 OSR > 1.063"/1.125" Brg O.D/ 2.767" ISR	B-1	A	PT1204	
		4 OSR > 1.188" Brg O.D./3.622" Stack-up	B-1	B / C	PT578	
All Models - M/T - 7.3L Dsl or 7.5L		4 OSR > 1.188" Brg O.D./3.622" Stack-up	B-1	A / B / C	PT578	

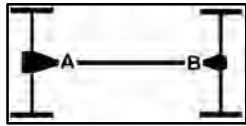

APPLICATION A-1

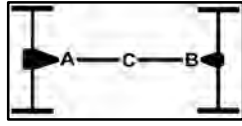

APPLICATION B-1

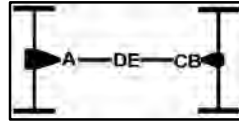

APPLICATION C-1

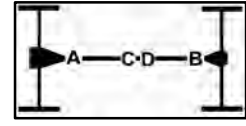

APPLICATION D-1

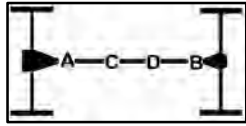

APPLICATION E-1

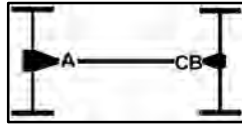

APPLICATION F-1

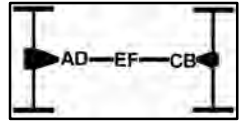

APPLICATION H-1

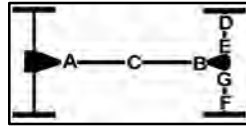

APPLICATION I-1

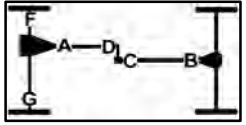

APPLICATION K-1

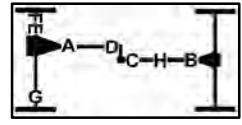

APPLICATION L-1

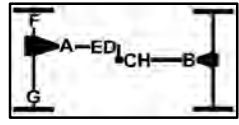

APPLICATION N-1



APPLICATION O-1

MAKE/YEARS FITMENT U-JOINT DESCRIPTION LOCATION POSITION PART NO.

FORD

FORD

F350 1 TON PICKUP 2WD					
1989	All Models - 2 Joint Drive Shaft - Exc. 5 Spd. M/T	4 OSR > 1.063" Brg O.D/ 3.622" Stack-up	A-1	A	PT530
		2 ISR & 2 OSR > 1.063"/1.125" Brg O.D/ 2.767" ISR	A-1	B	PT1204
	All Models - 2 Joint Drive Shaft - 5 Spd. M/T	4 OSR > 1.188" Brg O.D./3.622" Stack-up	A-1	A / B	PT578
		All Models - 3 Joint Drive Shaft			
		4 OSR > 1.188" Brg O.D./3.622" Stack-up	B-1	A / B / C	PT578
		2 ISR & 2 OSR > 1.063"/1.125" Brg O.D/ 2.767" ISR	B-1	A	PT1204
87-88	All Models - 2 Joint Drive Shaft - 5 Spd. M/T	4 OSR > 1.188" Brg O.D./3.622" Stack-up	A-1	A / B	PT578
		All Models - 2 Joint Drive Shaft - Exc. 5 Spd. M/T			
		4 OSR > 1.063" Brg O.D/ 3.622" Stack-up	A-1	A	PT530
		2 ISR & 2 OSR > 1.063"/1.125" Brg O.D/ 2.767" ISR	A-1	B	PT1204
	All Models - 3 Joint Drive Shaft - A/T	4 OSR > 1.063" Brg O.D/ 3.622" Stack-up	B-1	A / C	PT530
		2 ISR & 2 OSR > 1.063"/1.125" Brg O.D/ 2.767" ISR	B-1	B	PT1204
	All Models - 3 Joint Drive Shaft - Hvy Duty M/T	4 OSR > 1.188" Brg O.D./3.622" Stack-up	B-1	A / B / C	PT578
		All Models - 3 Joint Drive Shaft - Exc. Hvy Duty M/T - Exc. A/T			
		4 OSR > 1.063" Brg O.D/ 3.622" Stack-up	B-1	C	PT530
		2 ISR & 2 OSR > 1.063"/1.125" Brg O.D/ 2.767" ISR	B-1	A / B	PT1204
79-86	All Models	4 OSR > 1.063" Brg O.D/ 3.622" Stack-up	B-1	A / B / C	PT530
		4 OSR > 1.188" Brg O.D./3.622" Stack-up	B-1	B / C	PT578
		2 ISR & 2 OSR > 1.063"/1.125" Brg O.D/ 2.767" ISR	B-1	A / B / C	PT1204
77-78	All Models	4 OSR > 1.063" Brg O.D/ 3.622" Stack-up	B-1	A / B / C	PT530
		4 OSR > 1.188" Brg O.D./3.622" Stack-up	B-1	A / B / C	PT578
75-76	All Models - 5.9L or 7.5L - Exc. 155" Wheel Base	4 OSR > 1.188" Brg O.D./3.622" Stack-up	B-1	A / B / C	PT578
		All Models - Exc. 5.9L or 7.5L - Exc. 155" Wheel Base			
		4 OSR > 1.063" Brg O.D/ 3.622" Stack-up	B-1	A / B / C	PT530
	All Models - 155" Wheel Base	4 OSR > 1.063" Brg O.D/ 3.217" Stack-up	B-1	A	PT521HD
		4 OSR > 1.188" Brg O.D./3.622" Stack-up	B-1	B / C	PT578
		All Models - 5.9L or 7.5L			
		4 OSR > 1.063" Brg O.D/ 3.622" Stack-up	B-1	A	PT530
		4 OSR > 1.188" Brg O.D./3.622" Stack-up	B-1	B / C	PT578
	All Models - Exc. 5.9L or 7.5L	4 OSR > 1.063" Brg O.D/ 3.217" Stack-up	B-1	A	PT521HD
		4 OSR > 1.063" Brg O.D/3.622"-3.217" Stack-up	B-1	B / C	PT534

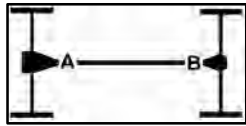

APPLICATION A-1

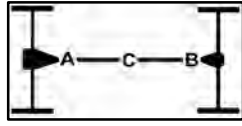

APPLICATION B-1

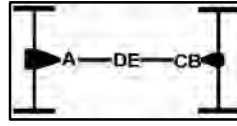

APPLICATION C-1

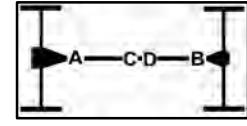

APPLICATION D-1

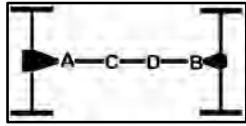

APPLICATION E-1

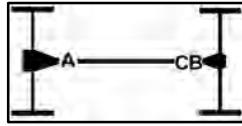

APPLICATION F-1

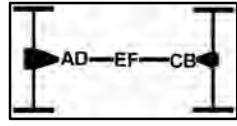

APPLICATION H-1

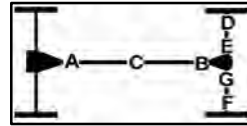

APPLICATION I-1

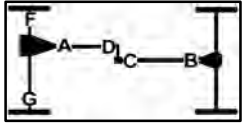

APPLICATION K-1

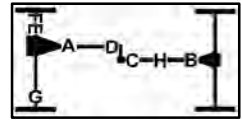

APPLICATION L-1

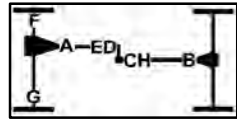

APPLICATION N-1

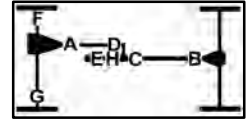

APPLICATION O-1

MAKE/YEARS FITMENT U-JOINT DESCRIPTION LOCATION POSITION PART NO.

FORD

FORD

F350 1 TON PICKUP 4WD

90-97 All Models - 2 or 3 Joint Drive Shaft	2 ISR & 2 OSR > 1.063"/1.125" Brg O.D/ 2.767" ISR	N-1	A / B	PT1204	
	4 OSR > 1.063" Brg O.D/ 3.622" Stack-up	N-1	C / D / E / H	PT530	
	4 OSR > 1.188" Brg O.D./3.622" Stack-up	N-1	B / C / H	PT578	
	4 ISR > 1.375" Brg O.D./2.995" Stack-up	N-1	F / G	PT332	
1989 All Models - 2 Joint Drive Shaft	2 ISR & 2 OSR > 1.063"/1.125" Brg O.D/ 2.767" ISR	L-1	A	PT1204	
	4 OSR > 1.063" Brg O.D/ 3.622" Stack-up	L-1	D	PT530	
	2 ISR & 2 OSR > 1.063"/1.125" Brg O.D/ 2.767" ISR	N-1	C	PT1204	
	4 OSR > 1.063" Brg O.D/ 3.622" Stack-up	N-1	B	PT530	
	4 OSR > 1.188" Brg O.D./3.622" Stack-up	N-1	B / C	PT578	
	All Models - 3 Joint Drive Shaft				
	2 ISR & 2 OSR > 1.063"/1.125" Brg O.D/ 2.767" ISR	N-1	A	PT1204	
	4 OSR > 1.063" Brg O.D/ 3.622" Stack-up	N-1	D / E	PT530	
	4 OSR > 1.188" Brg O.D./3.622" Stack-up	N-1	B / C / H	PT578	
All Models					
	4 ISR > 1.375" Brg O.D./2.995" Stack-up	N-1	F / G	PT332	
1988 All Models - 5.8L	2 ISR & 2 OSR > 1.063"/1.125" Brg O.D/ 2.555" ISR	N-1	D	PT3188	
	4 ISR > 1.125" Brg O.D./2.555" Stack-up	N-1	E	PT3105	
	All Models - Exc. 5.8L				
		2 ISR & 2 OSR > 1.063"/1.125" Brg O.D/ 2.767" ISR	N-1	A	PT1204
		4 OSR > 1.063" Brg O.D/ 3.622" Stack-up	N-1	D / E	PT530
		2 ISR & 2 OSR > 1.063"/1.125" Brg O.D/ 2.767" ISR	N-1	A	PT1204
	All Models - 2 or 3 Joint Drive Shaft				
		4 OSR > 1.063" Brg O.D/ 3.622" Stack-up	N-1	C	PT530
		2 ISR & 2 OSR > 1.063"/1.125" Brg O.D/ 2.767" ISR	N-1	B	PT1204
		4 OSR > 1.188" Brg O.D./3.622" Stack-up	N-1	B / C / H	PT578
All Models					
	4 ISR > 1.375" Brg O.D./2.995" Stack-up	N-1	F / G	PT332	
1987 All Models					
		4 OSR > 1.063" Brg O.D/ 3.622" Stack-up	N-1	D / E	PT530
		2 ISR & 2 OSR > 1.063"/1.125" Brg O.D/ 2.767" ISR	N-1	A	PT1204
	All Models - 2 or 3 Joint Drive Shaft - 5 Spd. M/T				
		4 OSR > 1.188" Brg O.D./3.622" Stack-up	N-1	B / C / H	PT578
	All Models - 2 or 3 Joint Drive Shaft - Exc. 5 Spd. M/T				
		4 OSR > 1.063" Brg O.D/ 3.622" Stack-up	N-1	C / H	PT530
	2 ISR & 2 OSR > 1.063"/1.125" Brg O.D/ 2.767" ISR	N-1	B / C	PT1204	
All Models					
	4 ISR > 1.375" Brg O.D./2.995" Stack-up	N-1	F / G	PT332	

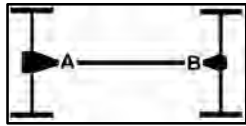

APPLICATION A-1

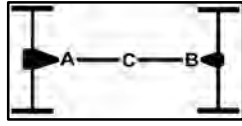

APPLICATION B-1

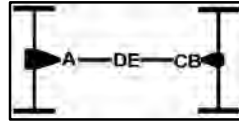

APPLICATION C-1

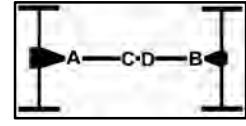

APPLICATION D-1

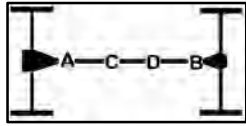

APPLICATION E-1

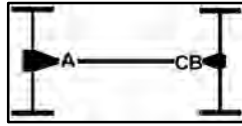

APPLICATION F-1

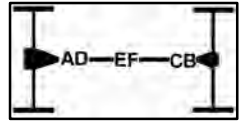

APPLICATION H-1

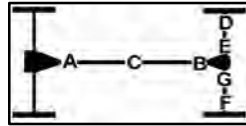

APPLICATION I-1

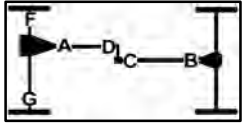

APPLICATION K-1

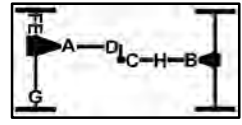

APPLICATION L-1

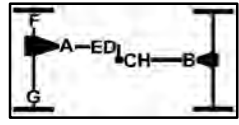

APPLICATION N-1



APPLICATION O-1

MAKE/YEARS FITMENT U-JOINT DESCRIPTION LOCATION POSITION PART NO.

FORD

FORD

MAKE/YEARS	FITMENT	U-JOINT DESCRIPTION	LOCATION	POSITION	PART NO.
F350 1 TON PICKUP 4WD					
1986	All Models	4 OSR > 1.063" Brg O.D/ 3.622" Stack-up	N-1	D / E / H	PT530
		2 ISR & 2 OSR > 1.063"/1.125" Brg O.D/ 2.767" ISR	N-1	A / B / C	PT1204
		4 ISR > 1.375" Brg O.D./2.995" Stack-up	N-1	F / G	PT332
1985	All Models - 2 Joint Drive Shaft	4 OSR > 1.063" Brg O.D/ 3.622" Stack-up	N-1	A / D	PT530
		2 ISR & 2 OSR > 1.063"/1.125" Brg O.D/ 2.767" ISR	N-1	B / C	PT1204
		4 ISR > 1.375" Brg O.D./2.995" Stack-up	N-1	F / G	PT332
	All Models - 3 Joint Drive Shaft	2 ISR & 2 OSR > 1.063"/1.125" Brg O.D/ 2.767" ISR	N-1	A / B / C / D / E	PT1204
		4 OSR > 1.063" Brg O.D/ 3.622" Stack-up	N-1	H	PT530
		4 OSR > 1.188" Brg O.D./3.622" Stack-up	L-1	E / F / G	PT578
82-84	All Models	2 ISR & 2 OSR > 1.063"/1.125" Brg O.D/ 2.767" ISR	L-1	A / B / C / D	PT1204
		4 OSR > 1.063" Brg O.D/ 3.622" Stack-up	L-1	H	PT530
		4 OSR > 1.188" Brg O.D./3.622" Stack-up	L-1	E / F / G	PT578
80-81	All Models	2 ISR & 2 OSR > 1.063"/1.125" Brg O.D/ 2.767" ISR	L-1	B / D	PT1204
		4 OSR > 1.063" Brg O.D/ 3.622" Stack-up	L-1	A / C	PT530
		4 ISR > 1.188" Brg O.D./2.187" Stack-up	L-1	E / F / G	PT297
		4 OSR > 1.188" Brg O.D./3.622" Stack-up	L-1	E / F / G	PT578
1979	All Models	2 ISR & 2 OSR > 1.063"/1.125" Brg O.D/ 2.767" ISR	N-1	A / B	PT1204
		4 OSR > 1.063" Brg O.D/ 3.622" Stack-up	N-1	C / D / E / H	PT530
		4 ISR > 1.375" Brg O.D./2.995" Stack-up	N-1	F / G	PT332
F350 SUPER DUTY 1 TON PICKUP 2WD					
05-06	All Models	4 OSR > 1.188" Brg O.D./4.182" Stack-up	B-1	A / B / C	PT560
99-04	All Models - 5.4L	4 OSR > 1.188" Brg O.D./3.622" Stack-up	B-1	A / B / C	PT578
	All Models - Exc. 5.4L	4 OSR > 1.188" Brg O.D./4.182" Stack-up	B-1	A / B / C	PT560
F350 SUPER DUTY 1 TON PICKUP 4WD					
05-06	All Models	4 OSR > 1.188" Brg O.D./3.622" Stack-up	N-1	A / D / E	PT578
		4 OSR > 1.188" Brg O.D./3.622" Stack-up	N-1	B / C	PT578
		4 OSR > 1.188" Brg O.D./4.182" Stack-up	N-1	B / C / H	PT560
		4 ISR > 1.375" Brg O.D./2.995" Stack-up	N-1	F / G	PT332
99-04	All Models	4 OSR > 1.188" Brg O.D./3.622" Stack-up	N-1	A / D / E	PT578
		4 OSR > 1.188" Brg O.D./3.622" Stack-up	N-1	B / C / H	PT578
		4 ISR > 1.375" Brg O.D./2.995" Stack-up	N-1	F / G	PT332

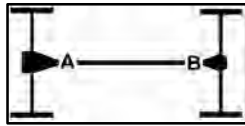

APPLICATION A-1

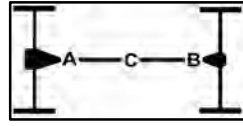

APPLICATION B-1

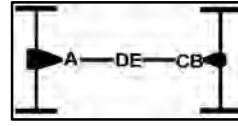

APPLICATION C-1

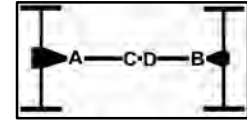

APPLICATION D-1

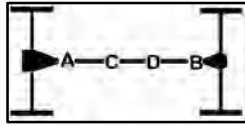

APPLICATION E-1

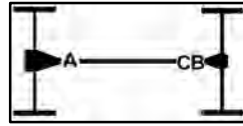

APPLICATION F-1

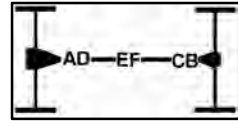

APPLICATION H-1

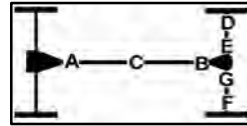

APPLICATION I-1

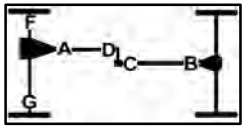

APPLICATION K-1

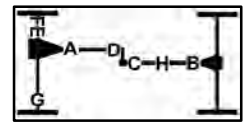

APPLICATION L-1

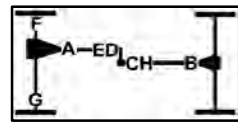

APPLICATION N-1



APPLICATION O-1

MAKE/YEARS FITMENT U-JOINT DESCRIPTION LOCATION POSITION PART NO.

FORD

FORD

MAKE/YEARS	FITMENT	U-JOINT DESCRIPTION	LOCATION	POSITION	PART NO.
F450/550 SUPER DUTY 2WD					
99-06	All Models	4 OSR > 1.375" Brg O.D./4.182" Stack-up	B-1	A / B / C	PT588
		4 OSR > 1.375" Brg O.D./4.182" Stack-up	E-1	A / B / C / D	PT588
F450/550 SUPER DUTY 4WD					
05-06	All Models	4 OSR > 1.188" Brg O.D./3.622" Stack-up	N-1	A / D / E	PT578
		4 OSR > 1.375" Brg O.D./4.182" Stack-up	N-1	B / C / H	PT588
		4 ISR > 1.375" Brg O.D./3.777" Stack-up	N-1	F / G	PT424
99-04	All Models	4 OSR > 1.188" Brg O.D./3.622" Stack-up	N-1	A / D / E	PT578
		4 OSR > 1.375" Brg O.D./4.182" Stack-up	N-1	B / C / H	PT588
		4 ISR > 1.375" Brg O.D./2.995" Stack-up	N-1	F / G	PT332
FAIRLANE					
1970	All Models	4 OSR > 1.063" Brg O.D/ 3.217" Stack-up	A-1	A	PT521HD
		4 OSR > 1.063" Brg O.D/ 3.622" Stack-up	A-1	A	PT530
		2ISR & 2OSR > 1.063"/1.125" Bearing caps	A-1	B	PT675
		2 ISR & 2 OSR > 1.063"/1.125" Brg O.D/ 2.767" ISR	A-1	B	PT1204
FAIRMONT					
79-83	All Models	4 OSR > 1.063" Brg O.D/ 3.217" Stack-up	A-1	A / B	PT521HD
1978	All Models	4 OSR > 1.063" Brg O.D/ 3.217" Stack-up	A-1	A	PT521HD
		2ISR & 2OSR > 1.063"/1.125" Bearing caps	A-1	B	PT675
FALCON					
1970	All Models	4 OSR > 1.063" Brg O.D/ 3.217" Stack-up	A-1	A	PT521HD
		2ISR & 2OSR > 1.063"/1.125" Bearing caps	A-1	B	PT675
GALAXIE					
70-74	All Models	4 OSR > 1.063" Brg O.D/ 3.217" Stack-up	A-1	A	PT521HD
		4 OSR > 1.063" Brg O.D/ 3.622" Stack-up	A-1	A	PT530
		2ISR & 2OSR > 1.063"/1.125" Bearing caps	A-1	B	PT675
		2 ISR & 2 OSR > 1.063"/1.125" Brg O.D/ 2.767" ISR	A-1	B	PT1204
GRAN TORINO					
75-76	All Models - 302 V-8 Engine	4 OSR > 1.063" Brg O.D/ 3.217" Stack-up	A-1	A	PT521HD
		2ISR & 2OSR > 1.063"/1.125" Bearing caps	A-1	B	PT675

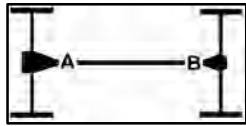

APPLICATION A-1

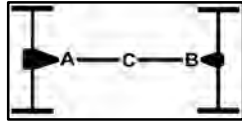

APPLICATION B-1

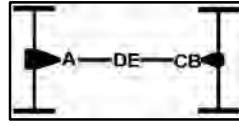

APPLICATION C-1

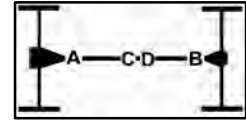

APPLICATION D-1

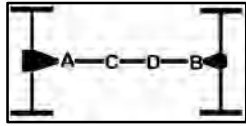

APPLICATION E-1

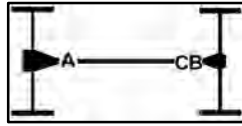

APPLICATION F-1

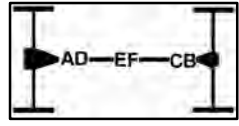

APPLICATION H-1

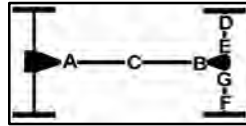

APPLICATION I-1

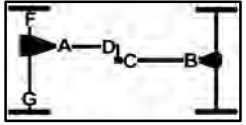

APPLICATION K-1

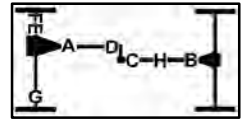

APPLICATION L-1

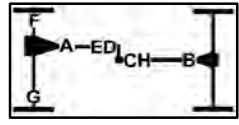

APPLICATION N-1



APPLICATION O-1

MAKE/YEARS FITMENT U-JOINT DESCRIPTION LOCATION POSITION PART NO.

FORD

FORD

MAKE/YEARS	FITMENT	U-JOINT DESCRIPTION	LOCATION	POSITION	PART NO.
GRAN TORINO					
75-76 All Models - 351 V-8 Engine					
		4 OSR > 1.063" Brg O.D/ 3.217" Stack-up	A-1	A	PT521HD
		2ISR & 2OSR > 1.063"/1.125" Bearing caps	A-1	B	PT675
		4 OSR > 1.063" Brg O.D/ 3.622" Stack-up	A-1	A	PT530
		2 ISR & 2 OSR > 1.063"/1.125" Brg O.D/ 2.767" ISR	A-1	B	PT1204
All Models - 400 or 460 V-8 Engine					
		4 OSR > 1.063" Brg O.D/ 3.622" Stack-up	A-1	A	PT530
		2 ISR & 2 OSR > 1.063"/1.125" Brg O.D/ 2.767" ISR	A-1	B	PT1204
72-74 All Models					
		4 OSR > 1.063" Brg O.D/ 3.217" Stack-up	A-1	A	PT521HD
		4 OSR > 1.063" Brg O.D/ 3.622" Stack-up	A-1	A	PT530
		2ISR & 2OSR > 1.063"/1.125" Bearing caps	A-1	B	PT675
		2 ISR & 2 OSR > 1.063"/1.125" Brg O.D/ 2.767" ISR	A-1	B	PT1204
GRANADA					
81-83 All Models					
		4 OSR > 1.063" Brg O.D/ 3.217" Stack-up	A-1	A / B	PT521HD
78-80 All Models					
		4 OSR > 1.063" Brg O.D/ 3.217" Stack-up	A-1	A	PT521HD
		2ISR & 2OSR > 1.063"/1.125" Bearing caps	A-1	B	PT675
75-77 All Models					
		4 OSR > 1.063" Brg O.D/ 3.217" Stack-up	A-1	A	PT521HD
		4 OSR > 1.063" Brg O.D/ 3.622" Stack-up	A-1	A	PT530
		2ISR & 2OSR > 1.063"/1.125" Bearing caps	A-1	B	PT675
		2 ISR & 2 OSR > 1.063"/1.125" Brg O.D/ 2.767" ISR	A-1	B	PT1204
LTD					
79-91 All Models					
		4 OSR > 1.063" Brg O.D/ 3.217" Stack-up	A-1	A / B	PT521HD
		4 OSR > 1.063" Brg O.D/ 3.622" Stack-up	A-1	A / B	PT530
75-78 All Models - 302 V-8 Engine					
		4 OSR > 1.063" Brg O.D/ 3.217" Stack-up	A-1	A	PT521HD
		2ISR & 2OSR > 1.063"/1.125" Bearing caps	A-1	B	PT675
All Models - 351 V-8 Engine					
		4 OSR > 1.063" Brg O.D/ 3.217" Stack-up	A-1	A	PT521HD
		2ISR & 2OSR > 1.063"/1.125" Bearing caps	A-1	B	PT675
		4 OSR > 1.063" Brg O.D/ 3.622" Stack-up	A-1	A	PT530
		2 ISR & 2 OSR > 1.063"/1.125" Brg O.D/ 2.767" ISR	A-1	B	PT1204
All Models - 400 or 460 V-8 Engine					
		4 OSR > 1.063" Brg O.D/ 3.622" Stack-up	A-1	A	PT530
		2 ISR & 2 OSR > 1.063"/1.125" Brg O.D/ 2.767" ISR	A-1	B	PT1204

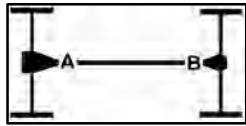

APPLICATION A-1

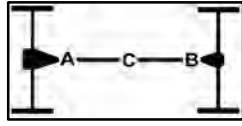

APPLICATION B-1

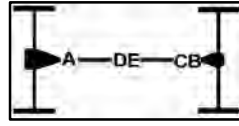

APPLICATION C-1

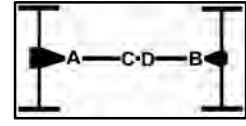

APPLICATION D-1

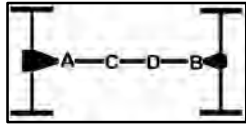

APPLICATION E-1

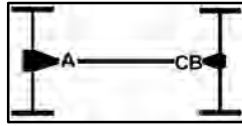

APPLICATION F-1

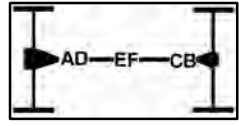

APPLICATION H-1

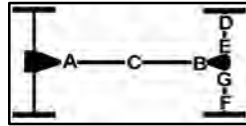

APPLICATION I-1

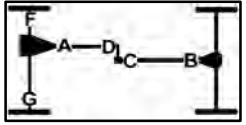

APPLICATION K-1

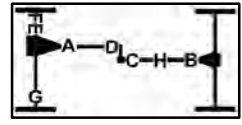

APPLICATION L-1

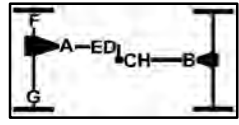

APPLICATION N-1



APPLICATION O-1

MAKE/YEARS FITMENT U-JOINT DESCRIPTION LOCATION POSITION PART NO.

FORD

FORD

MAKE/YEARS	FITMENT	U-JOINT DESCRIPTION	LOCATION	POSITION	PART NO.
LTD					
70-74	All Models	4 OSR > 1.063" Brg O.D/ 3.217" Stack-up	A-1	A	PT521HD
		4 OSR > 1.063" Brg O.D/ 3.622" Stack-up	A-1	A	PT530
		2ISR & 2OSR > 1.063"/1.125" Bearing caps	A-1	B	PT675
		2 ISR & 2 OSR > 1.063"/1.125" Brg O.D/ 2.767" ISR	A-1	B	PT1204
MAVERICK					
70-77	All Models	4 OSR > 1.063" Brg O.D/ 3.217" Stack-up	A-1	A	PT521HD
		2ISR & 2OSR > 1.063"/1.125" Bearing caps	A-1	B	PT675
MUSTANG					
01-04	All Models - Cobra	4 OSR > 1.188" Brg O.D./3.622" Stack-up	A-1	A / B	PT578
	All Models - Exc. Cobra	4 OSR > 1.063" Brg O.D/ 3.622" Stack-up	A-1	A / B	PT530
96-00	All Models	4 OSR > 1.063" Brg O.D/ 3.622" Stack-up	A-1	A / B	PT530
87-95	All Models	4 OSR > 1.063" Brg O.D/ 3.217" Stack-up	A-1	A / B	PT521HD
		4 OSR > 1.063" Brg O.D/ 3.622" Stack-up	A-1	A / B	PT530
79-86	All Models	4 OSR > 1.063" Brg O.D/ 3.217" Stack-up	A-1	A / B	PT521HD
74-78	All Models	4 OSR > 1.063" Brg O.D/ 3.217" Stack-up	A-1	A	PT521HD
		2ISR & 2OSR > 1.063"/1.125" Bearing caps	A-1	B	PT675
70-73	All Models	4 OSR > 1.063" Brg O.D/ 3.217" Stack-up	A-1	A	PT521HD
		4 OSR > 1.063" Brg O.D/ 3.622" Stack-up	A-1	A	PT530
		2ISR & 2OSR > 1.063"/1.125" Bearing caps	A-1	B	PT675
		2 ISR & 2 OSR > 1.063"/1.125" Brg O.D/ 2.767" ISR	A-1	B	PT1204
PINTO					
71-80	All Models	4 OSR > 1.063" Brg O.D/ 3.217" Stack-up	A-1	A / B	PT521HD
71-79	All Models	4 OSR > 1.063" Brg O.D/ 3.217" Stack-up	A-1	A	PT521HD
		2ISR & 2OSR > 1.063"/1.125" Bearing caps	A-1	B	PT675
RANGER 2WD					
98-06	All Models	4 OSR > 1.063" Brg O.D/ 3.622" Stack-up	A-1	A / B	PT530
90-97	All Models - Regular Cab	4 OSR > 1.063" Brg O.D/ 3.217" Stack-up	A-1	A / B	PT521HD
	All Models - Super Cab	4 OSR > 1.063" Brg O.D/ 3.217" Stack-up	A-1	A / B / C	PT521HD

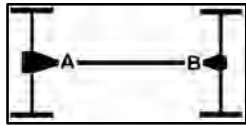

APPLICATION A-1

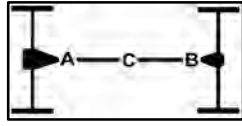

APPLICATION B-1

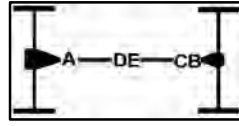

APPLICATION C-1

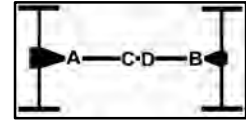

APPLICATION D-1

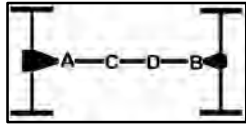

APPLICATION E-1

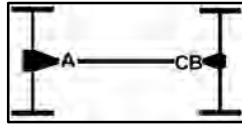

APPLICATION F-1

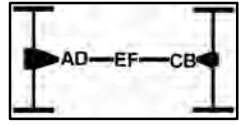

APPLICATION H-1

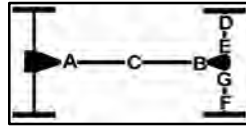

APPLICATION I-1

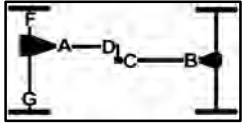

APPLICATION K-1

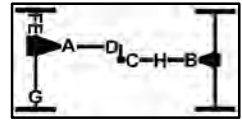

APPLICATION L-1

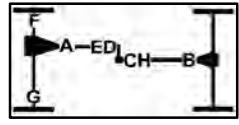

APPLICATION N-1



APPLICATION O-1

MAKE/YEARS FITMENT U-JOINT DESCRIPTION LOCATION POSITION PART NO.

FORD

FORD

MAKE/YEARS	FITMENT	U-JOINT DESCRIPTION	LOCATION	POSITION	PART NO.
RANGER 2WD					
88-89	All Models - Regular Cab	4 OSR > 1.063" Brg O.D/ 3.217" Stack-up	A-1	A / B	PT521HD
		2ISR & 2OSR > 1.063"/1.125" Bearing caps	A-1	B	PT675
	All Models - Super Cab	4 OSR > 1.063" Brg O.D/ 3.217" Stack-up	A-1	A	PT521HD
		4 OSR > 1.063" Brg O.D./2.437" Stack-up	A-1	A / B / C	PT315
86-87	All Models - Regular Cab	4 OSR > 1.063" Brg O.D/ 3.217" Stack-up	A-1	A / B	PT521HD
	All Models - Super Cab	4 OSR > 1.063" Brg O.D./2.437" Stack-up	A-1	A / B / C	PT315
83-85	All Models	4 OSR > 1.063" Brg O.D/ 3.217" Stack-up	A-1	A / B	PT521HD
RANGER 4WD					
98-06	All Models	4 OSR > 1.063" Brg O.D/ 3.217" Stack-up	N-1	A / D / E	PT521HD
		4 OSR > 1.063" Brg O.D/ 3.622" Stack-up	N-1	B / C / H	PT530
90-97	All Models	4 OSR > 1.063" Brg O.D/ 3.217" Stack-up	N-1	A / D / E	PT521HD
		4 OSR > 1.063" Brg O.D/ 3.217" Stack-up	N-1	B / C / H	PT521HD
		4 ISR > 1.188" Brg O.D./2.187" Stack-up	N-1	E / F / G	PT297
		4 ISR & 4OSR > 1.063" Brg O.D./1.635" ISR - 2.437" OSR Stack-up	N-1	E / F / G	PT456
1989	All Models	4 OSR > 1.063" Brg O.D/ 3.217" Stack-up	L-1	A / B / D	PT521HD
		4 OSR > 1.063" Brg O.D./2.437" Stack-up	L-1	A / B / C / D / H	PT315
		4 ISR & 4OSR > 1.063" Brg O.D./1.635" ISR - 2.437" OSR Stack-up	L-1	E / F / G	PT456
87-88	All Models - STX Package	4 OSR > 1.063" Brg O.D./2.437" Stack-up	L-1	A / D	PT315
	All Models - Exc. STX Package	4 OSR > 1.063" Brg O.D/ 3.217" Stack-up	L-1	A / D	PT521HD
	All Models - 108", 114" or 125" Wheel Base	4 OSR > 1.063" Brg O.D./2.437" Stack-up	L-1	B / C / H	PT315
	All Models	4 ISR & 4OSR > 1.063" Brg O.D./1.635" ISR - 2.437" OSR Stack-up	L-1	E / F / G	PT456
1986	All Models	4 OSR > 1.063" Brg O.D/ 3.217" Stack-up	L-1	A / D	PT521HD
	All Models - 108" or 114" Wheel Base	4 OSR > 1.063" Brg O.D./2.437" Stack-up	L-1	B / C / H	PT315
	All Models - 125" Wheel Base; Exc. 5 Spd. M/T	4 OSR > 1.063" Brg O.D./2.437" Stack-up	L-1	B / C	PT315

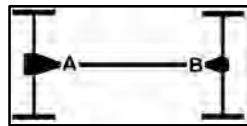

APPLICATION A-1

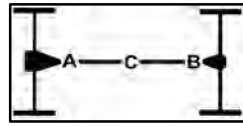

APPLICATION B-1

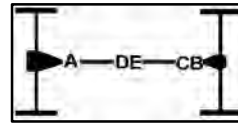

APPLICATION C-1

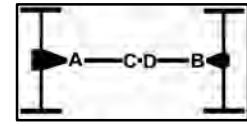

APPLICATION D-1

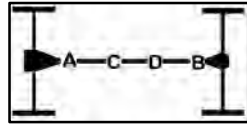

APPLICATION E-1

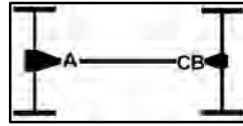

APPLICATION F-1

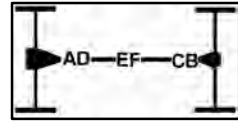

APPLICATION H-1

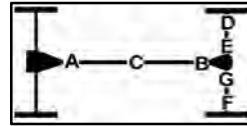

APPLICATION I-1

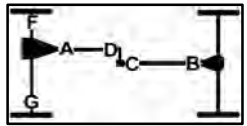

APPLICATION K-1

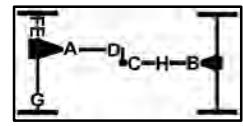

APPLICATION L-1

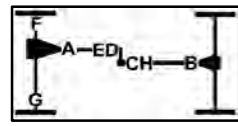

APPLICATION N-1



APPLICATION O-1

MAKE/YEARS FITMENT U-JOINT DESCRIPTION LOCATION POSITION PART NO.

FORD

FORD

RANGER 4WD						
1986	All Models - 125" Wheel Base; 5 Spd. M/T	2 ISR & 2 OSR > 1.063"/1.125" Brg O.D/ 2.767" ISR	L-1	B	PT1204	
		4 OSR > 1.063" Brg O.D/ 3.622" Stack-up	L-1	C	PT530	
All Models		4 ISR & 4OSR > 1.063" Brg O.D./1.635" ISR - 2.437" OSR Stack-up	L-1	E / F / G	PT456	
1985	All Models	4 OSR > 1.063" Brg O.D/ 3.217" Stack-up	L-1	A / D	PT521HD	
		4 OSR > 1.063" Brg O.D./2.437" Stack-up	L-1	B / C / H	PT315	
		4 ISR & 4OSR > 1.063" Brg O.D./1.635" ISR - 2.437" OSR Stack-up	L-1	E / F / G	PT456	
83-84	All Models - Exc. 5 Spd. M/T	4 OSR > 1.063" Brg O.D/ 3.217" Stack-up	L-1	A / D	PT521HD	
		All Models - 5 Spd. M/T				
	4 OSR > 1.063" Brg O.D./2.437" Stack-up	L-1	D	PT315		
	4 OSR > 1.063" Brg O.D/ 3.217" Stack-up	L-1	A	PT521HD		
	All Models		4 OSR > 1.063" Brg O.D./2.437" Stack-up	L-1	B / C / H	PT315
	4 ISR & 4OSR > 1.063" Brg O.D./1.635" ISR - 2.437" OSR Stack-up	L-1	E / F / G	PT456		
TEMPO AWD						
86-94	All Models	4 OSR > 1.063" Brg O.D./2.437" Stack-up	B-1	A / B / C	PT315	
		All Models - Wheel Joints				
		4 OSR > 1.063" Brg O.D./2.437" Stack-up	4 LOCATIONS		PT315	
THUNDERBIRD						
94-97	All Models	4 OSR > 1.063" Brg O.D/ 3.622" Stack-up	A-1	A / B	PT530	
87-93	All Models	4 OSR > 1.063" Brg O.D/ 3.217" Stack-up	A-1	A / B	PT521HD	
		4 OSR > 1.063" Brg O.D/ 3.622" Stack-up	A-1	A / B	PT530	
83-86	All Models	4 OSR > 1.063" Brg O.D/ 3.217" Stack-up	A-1	A / B	PT521HD	
80-82	All Models	4 OSR > 1.063" Brg O.D/ 3.217" Stack-up	F-1	A / B / C	PT521HD	
1979	All Models	4 OSR > 1.063" Brg O.D/ 3.622" Stack-up	A-1	A	PT530	
		4 ISR > 1.125" Brg O.D./2.555 Stack-up	A-1	A	PT3105	
		2 ISR & 2 OSR > 1.063"/1.125" Brg O.D/ 2.767" ISR	A-1	B	PT1204	
		2 ISR & 2 OSR > 1.125" Brg O.D./2.555" ISR - 3.622" OSR Stack-up	A-1	B	PT352	
77-78	All Models	4 OSR > 1.063" Brg O.D/ 3.622" Stack-up	A-1	A	PT530	
		2 ISR & 2 OSR > 1.063"/1.125" Brg O.D/ 2.767" ISR	A-1	B	PT1204	
73-76	All Models	4 OSR > 1.063" Brg O.D/ 3.622" Stack-up	A-1	A / B	PT530	

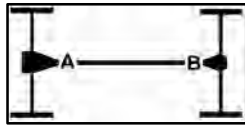

APPLICATION A-1

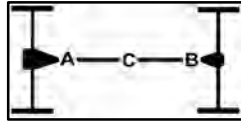

APPLICATION B-1

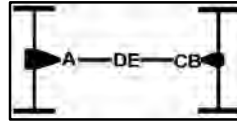

APPLICATION C-1

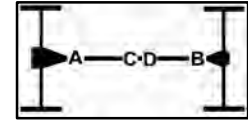

APPLICATION D-1

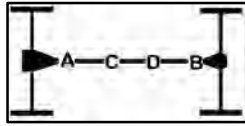

APPLICATION E-1

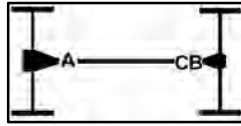

APPLICATION F-1

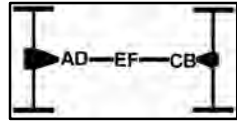

APPLICATION H-1

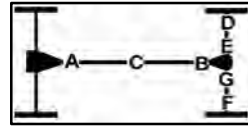

APPLICATION I-1

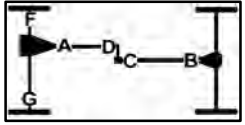

APPLICATION K-1

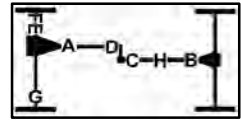

APPLICATION L-1

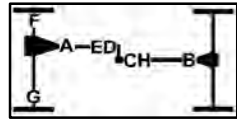

APPLICATION N-1



APPLICATION O-1

MAKE/YEARS FITMENT U-JOINT DESCRIPTION LOCATION POSITION PART NO.

FORD

FORD

THUNDERBIRD					
1972 All Models	4 OSR > 1.063" Brg O.D/ 3.622" Stack-up	A-1	A	PT530	
	2 ISR & 2 OSR > 1.063"/1.125" Brg O.D/ 2.767" ISR	A-1	B	PT1204	
70-71 All Models - 2 At Each Location					
	4 ISR > 1.125" Brg O.D./2.555 Stack-up	A-1	A / B	PT3105	
TORINO					
75-76 All Models - 302 V-8 Engine	4 OSR > 1.063" Brg O.D/ 3.217" Stack-up	A-1	A	PT521HD	
	2ISR & 2OSR > 1.063"/1.125" Bearing caps	A-1	B	PT675	
All Models - 351 V-8 Engine					
	4 OSR > 1.063" Brg O.D/ 3.217" Stack-up	A-1	A	PT521HD	
	2ISR & 2OSR > 1.063"/1.125" Bearing caps	A-1	B	PT675	
	4 OSR > 1.063" Brg O.D/ 3.622" Stack-up	A-1	A	PT530	
	2 ISR & 2 OSR > 1.063"/1.125" Brg O.D/ 2.767" ISR	A-1	B	PT1204	
All Models - 400 or 460 V-8 Engine					
	4 OSR > 1.063" Brg O.D/ 3.622" Stack-up	A-1	A	PT530	
	2 ISR & 2 OSR > 1.063"/1.125" Brg O.D/ 2.767" ISR	A-1	B	PT1204	
70-74 All Models	4 OSR > 1.063" Brg O.D/ 3.217" Stack-up	A-1	A	PT521HD	
	4 OSR > 1.063" Brg O.D/ 3.622" Stack-up	A-1	A	PT530	
	2ISR & 2OSR > 1.063"/1.125" Bearing caps	A-1	B	PT675	
	2 ISR & 2 OSR > 1.063"/1.125" Brg O.D/ 2.767" ISR	A-1	B	PT1204	

GEO

GEO

TRACKER 2WD					
89-97 All Models	4 OSR > .985" Brg O.D./2.498" Stack-up	A-1	A / B	PT1601	
TRACKER 4WD					
All Models	4 OSR > .985" Brg O.D./2.498" Stack-up	K-1	A / B / C / D	PT1601	

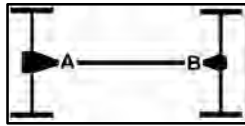

APPLICATION A-1

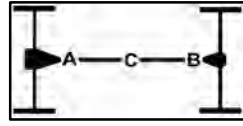

APPLICATION B-1

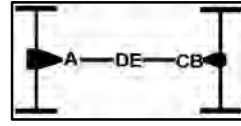

APPLICATION C-1

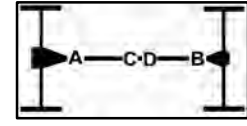

APPLICATION D-1

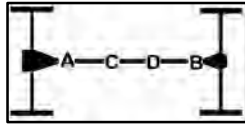

APPLICATION E-1

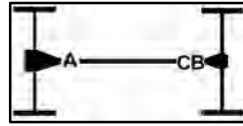

APPLICATION F-1

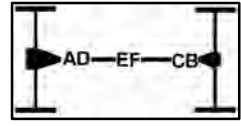

APPLICATION H-1

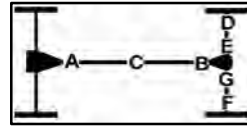

APPLICATION I-1

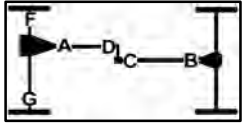

APPLICATION K-1

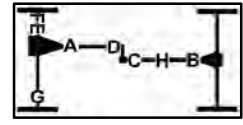

APPLICATION L-1

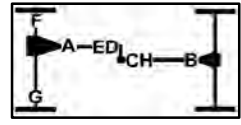

APPLICATION N-1

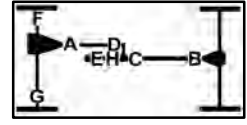

APPLICATION O-1

MAKE/YEARS FITMENT U-JOINT DESCRIPTION LOCATION POSITION PART NO.

GMC

GMC

C1500 1/2 TON PICKUP 2WD						
96-99 All Models-Regular Cab; Short Bed	4 ISR > 1.125" Brg O.D./2.555 Stack-up	A-1	A / B	PT3105		
	All Models-Regular Cab-Long Bed or Ext. Cab-M/T					
	4 OSR > 1.063" Brg O.D/ 3.622" Stack-up	B-1	A / C	PT530		
	2 ISR & 2 OSR > 1.063"/1.125" Brg O.D/ 2.555" ISR	B-1	B	PT3188		
All Models-Ext. Cab; A/T						
	4 OSR > 1.188" Brg O.D./3.622" Stack-up	B-1	A / B / C	PT578		
92-95 All Models-Regular Cab; Short Bed; Exc. A/T	4 ISR > 1.125" Brg O.D./2.555 Stack-up	A-1	A / B	PT3105		
	All Models-Regular Cab; Short Bed; A/T					
	4 OSR > 1.188" Brg O.D./3.622" Stack-up	A-1	A / B	PT578		
	All Models-Regular Cab; Long Bed-A/T or M/T-Exc. Heavy Duty					
	4 OSR > 1.063" Brg O.D/ 3.622" Stack-up	A-1	A	PT530		
	2 ISR & 2 OSR > 1.063"/1.125" Brg O.D/ 2.555" ISR	A-1	B	PT3188		
	All Models-Regular or Extended Cab; M/T; Heavy Duty					
4 OSR > 1.188" Brg O.D./3.622" Stack-up	B-1	A / B / C	PT578			
All Models-Extended Cab; A/T						
	4 ISR > 1.125" Brg O.D./2.555 Stack-up	B-1	A / B / C	PT3105		
All Models-Extended Cab; M/T; Exc. Heavy Duty or Turbo Diesel Engine						
	4 OSR > 1.063" Brg O.D/ 3.622" Stack-up	B-1	A / C	PT530		
	2 ISR & 2 OSR > 1.063"/1.125" Brg O.D/ 2.555" ISR	B-1	B	PT3188		
88-91 All Models-2 Joint Driveshaft; Regular Cab	4 OSR > 1.188" Brg O.D./3.622" Stack-up	A-1	A / B	PT578		
	4 ISR > 1.125" Brg O.D./2.555 Stack-up	A-1	A / B	PT3105		
	4 OSR > 1.063" Brg O.D/ 3.622" Stack-up	A-1	A	PT530		
	2 ISR & 2 OSR > 1.063"/1.125" Brg O.D/ 2.555" ISR	A-1	B	PT3188		
	All Models-3 Joint Driveshaft-Regular Cab or Extended Cab-5 Spd. M/T					
	4 OSR > 1.188" Brg O.D./3.622" Stack-up	B-1	A / B / C	PT578		
	All Models-Extended Cab; A/T					
	4 ISR > 1.125" Brg O.D./2.555 Stack-up	B-1	A / B / C	PT3105		
	4 OSR > 1.188" Brg O.D./3.622" Stack-up	B-1	C	PT578		
	All Models-Extended Cab; 5 Spd. M/T					
4 OSR > 1.063" Brg O.D/ 3.622" Stack-up	B-1	A / C	PT530			
2 ISR & 2 OSR > 1.063"/1.125" Brg O.D/ 2.555" ISR	B-1	B	PT3188			
82-86 All Models-2 Joint Driveshaft	4 ISR > 1.125" Brg O.D./2.555 Stack-up	A-1	A / B	PT3105		
	All Models-3 Joint Driveshaft					
	4 ISR > 1.125" Brg O.D./2.555 Stack-up	B-1	A / B / C	PT3105		
	4 OSR > 1.188" Brg O.D./3.622" Stack-up	B-1	A / B / C	PT578		

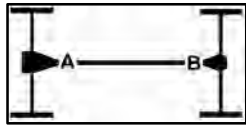

APPLICATION A-1

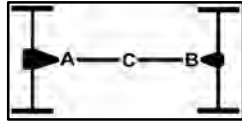

APPLICATION B-1

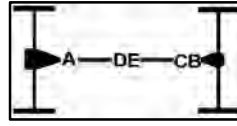

APPLICATION C-1

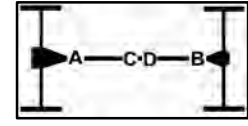

APPLICATION D-1

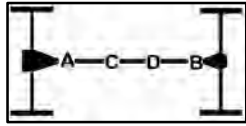

APPLICATION E-1

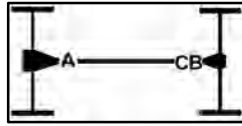

APPLICATION F-1

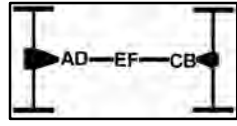

APPLICATION H-1

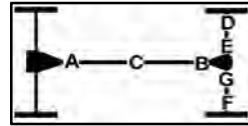

APPLICATION I-1

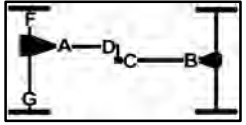

APPLICATION K-1

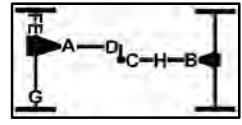

APPLICATION L-1

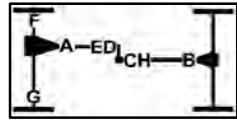

APPLICATION N-1



APPLICATION O-1

MAKE/YEARS FITMENT U-JOINT DESCRIPTION LOCATION POSITION PART NO.

GMC

GMC

C1500 1/2 TON PICKUP 2WD

79-81 All Models-2 Joint Driveshaft	4 OSR > 1.063" Brg O.D/ 3.217" Stack-up	A-1	A / B	PT521HD
All Models-3 Joint Driveshaft	4 OSR > 1.063" Brg O.D/ 3.217" Stack-up	B-1	A / B / C	PT521HD
	4 OSR > 1.188" Brg O.D./3.622" Stack-up	B-1	A / B / C	PT578
	2 ISR & 2 OSR > 1.063"/1.125" Brg O.D/ 2.555" ISR	B-1	B	PT3188
1978 All Models-With 2 Joint Driveshaft	4 OSR > 1.063" Brg O.D/ 3.217" Stack-up	A-1	A / B	PT521HD
All Models-With 3 Joint Driveshaft; Turbo	4 OSR > 1.188" Brg O.D./3.622" Stack-up	B-1	A / B	PT578
	4 ISR > 1.125" Brg O.D./2.555 Stack-up	B-1	C	PT3105
All Models-With 3 Joint Driveshaft; Exc. Turbo	4 OSR > 1.063" Brg O.D/ 3.217" Stack-up	B-1	A / B / C	PT521HD
70-77 All Models-2 Joint Driveshaft	4 OSR > 1.188" Brg O.D./3.622" Stack-up	A-1	A	PT578
	4 OSR > 1.063" Brg O.D/ 3.622" Stack-up	A-1	A	PT530
	4 OSR > 1.063" Brg O.D/ 3.217" Stack-up	A-1	A / B	PT521HD
All Models-3 Joint Driveshaft	4 OSR > 1.063" Brg O.D/ 3.217" Stack-up	B-1	A / B / C	PT521HD
	4 OSR > 1.188" Brg O.D./3.622" Stack-up	B-1	A / B / C	PT578
	4 OSR > 1.063" Brg O.D/ 3.622" Stack-up	B-1	A / B	PT530

C1500 1/2 TON SUBURBAN 2WD

96-99 All Models-Diesel	4 OSR > 1.188" Brg O.D./3.622" Stack-up	A-1	A / B	PT578
All Models-Exc. Diesel	4 OSR > 1.063" Brg O.D/ 3.622" Stack-up	A-1	A	PT530
	2 ISR & 2 OSR > 1.063"/1.125" Brg O.D/ 2.555" ISR	A-1	B	PT3188
1995 All Models-With 4 Speed Transmission	4 OSR > 1.188" Brg O.D./3.622" Stack-up	A-1	A / B	PT578
All Models-Without 4 Speed Transmission	4 OSR > 1.063" Brg O.D/ 3.622" Stack-up	A-1	A	PT530
	2 ISR & 2 OSR > 1.063"/1.125" Brg O.D/ 2.555" ISR	A-1	B	PT3188
1994 All Models	4 OSR > 1.063" Brg O.D/ 3.622" Stack-up	A-1	A	PT530
	2 ISR & 2 OSR > 1.063"/1.125" Brg O.D/ 2.555" ISR	A-1	B	PT3188

C2500 3/4 TON PICKUP 2WD

88-00 All Models	4 OSR > 1.188" Brg O.D./3.622" Stack-up	B-1	A / B / C	PT578
82-86 All Models	4 OSR > 1.188" Brg O.D./3.622" Stack-up	B-1	A / B / C	PT578
	4 ISR > 1.125" Brg O.D./2.555 Stack-up	B-1	A / B / C	PT3105

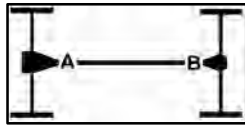

APPLICATION A-1

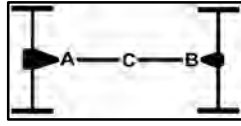

APPLICATION B-1

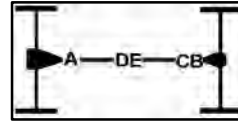

APPLICATION C-1

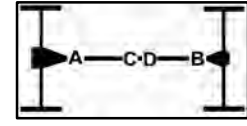

APPLICATION D-1

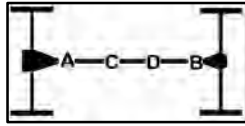

APPLICATION E-1

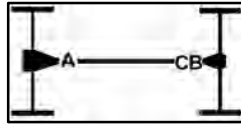

APPLICATION F-1

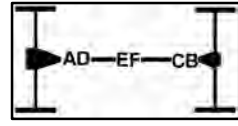

APPLICATION H-1

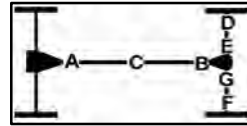

APPLICATION I-1

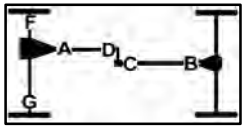

APPLICATION K-1

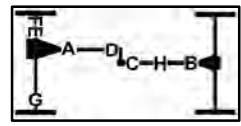

APPLICATION L-1

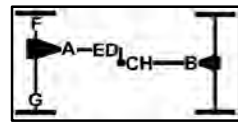

APPLICATION N-1



APPLICATION O-1

MAKE/YEARS FITMENT U-JOINT DESCRIPTION LOCATION POSITION PART NO.

GMC

GMC

MAKE/YEARS	FITMENT	U-JOINT DESCRIPTION	LOCATION	POSITION	PART NO.
C2500 3/4 TON PICKUP 2WD					
1981	All Models-2 Door	4 OSR > 1.188" Brg O.D./3.622" Stack-up	B-1	A / C	PT578
		4 ISR > 1.125" Brg O.D./2.555 Stack-up	B-1	B	PT3105
		4 OSR > 1.063" Brg O.D/ 3.217" Stack-up	B-1	A / C	PT521HD
	All Models-4 Door	4 OSR > 1.188" Brg O.D./3.622" Stack-up	B-1	A / B / C	PT578
		4 OSR > 1.063" Brg O.D/ 3.217" Stack-up	B-1	C	PT521HD
70-80	All Models	4 OSR > 1.188" Brg O.D./3.622" Stack-up	B-1	A / B / C	PT578
		4 OSR > 1.063" Brg O.D/ 3.217" Stack-up	B-1	A / B / C	PT521HD
		4 OSR > 1.063" Brg O.D/ 3.622" Stack-up	B-1	A	PT530
C2500 3/4 TON SUBURBAN 2WD					
94-99	All Models	4 OSR > 1.188" Brg O.D./3.622" Stack-up	B-1	A / B	PT578
C3500 1 TON PICKUP 2WD					
88-00	All Models-3 or 4 Joint Driveshaft	4 OSR > 1.188" Brg O.D./3.622" Stack-up	B-1	A / B / C	PT578
		4 OSR > 1.188" Brg O.D./4.182" Stack-up	C-1	A / B / C / D	PT560
79-86	All Models	4 OSR > 1.188" Brg O.D./3.622" Stack-up	B-1	A / B / C	PT578
70-78	All Models	4 OSR > 1.063" Brg O.D/ 3.217" Stack-up	B-1	A / C	PT521HD
		4 OSR > 1.063" Brg O.D/ 3.622" Stack-up	B-1	A	PT530
		4 OSR > 1.188" Brg O.D./3.622" Stack-up	B-1	A / B / C	PT578
C3500HD 1 TON PICKUP 2WD					
2002	All Models-2 or 3 Joint Driveshaft	4 OSR > 1.188" Brg O.D./4.182" Stack-up	B-1	A / B / C	PT560
91-01	All Models-3 or 4 Joint Driveshaft	4 OSR > 1.188" Brg O.D./4.182" Stack-up	C-1	A / B / C / D	PT560
		4 OSR > 1.188" Brg O.D./3.622" Stack-up	C-1	A / B / C / D	PT578
CABALLERO					
78-87	All Models	4 ISR > 1.125" Brg O.D./2.555 Stack-up	A-1	A / B	PT3105
		4 OSR > 1.063" Brg O.D/ 3.217" Stack-up	A-1	A / B	PT521HD
CANYON 2WD					
04-06	All Models	4 OSR > 1.063" Brg O.D/ 3.622" Stack-up	B-1	A / C	PT530
		2 ISR & 2 OSR > 1.063"/1.125" Brg O.D/ 2.555" ISR	B-1	B	PT3188

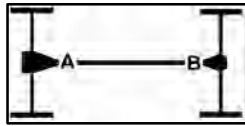

APPLICATION A-1

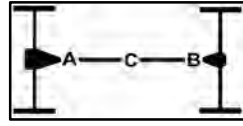

APPLICATION B-1

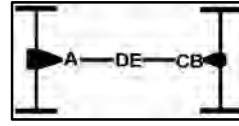

APPLICATION C-1

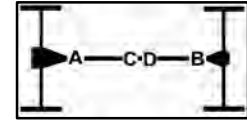

APPLICATION D-1

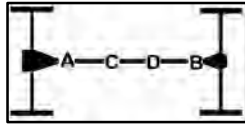

APPLICATION E-1

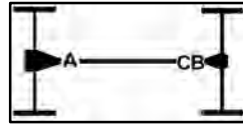

APPLICATION F-1

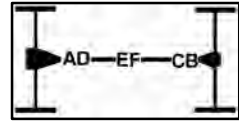

APPLICATION H-1

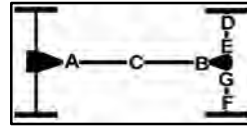

APPLICATION I-1

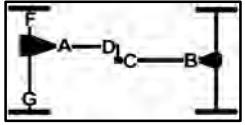

APPLICATION K-1

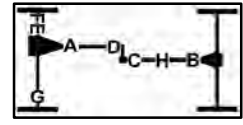

APPLICATION L-1

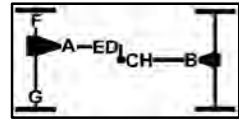

APPLICATION N-1

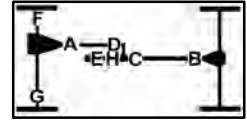

APPLICATION O-1

MAKE/YEARS FITMENT U-JOINT DESCRIPTION LOCATION POSITION PART NO.

GMC

GMC

MAKE/YEARS	FITMENT	U-JOINT DESCRIPTION	LOCATION	POSITION	PART NO.
CANYON 4WD					
04-06	All Models	4 OSR > 1.063" Brg O.D/ 3.217" Stack-up	L-1	A	PT521HD
		4 OSR > 1.063" Brg O.D/ 3.622" Stack-up	L-1	C	PT530
		2 ISR & 2 OSR > 1.063"/1.125" Brg O.D/ 2.555" ISR	L-1	B	PT3188
ENVOY 2WD					
02-06	All Models	4 ISR > 1.125" Brg O.D./2.555 Stack-up	A-1	A / B	PT3105
98-00	All Models	4 ISR > 1.125" Brg O.D./2.555 Stack-up	A-1	A / B	PT3105
ENVOY 4WD					
02-06	All Models	2 ISR & 2 OSR > 1.063" Brg O.D/ 3.217" OSR - 2.344" ISR Stack-up	L-1	A	PT445
		4 ISR > 1.125" Brg O.D./2.555 Stack-up	L-1	B / C	PT3105
98-00	All Models	2 ISR & 2 OSR > 1.063" Brg O.D/ 3.217" OSR - 2.344" ISR Stack-up	L-1	A	PT445
		4 ISR > 1.125" Brg O.D./2.555 Stack-up	L-1	B / C	PT3105
G1500 1/2 TON VAN 2WD					
97-02	All Models	4 OSR > 1.188" Brg O.D./3.622" Stack-up	A-1	A / B	PT578
1996	All Models-2 Joint Driveshaft; 110" WB	4 ISR > 1.125" Brg O.D./2.555 Stack-up	A-1	A / B	PT3105
	All Models-2 Joint Driveshaft; 120" WB	4 OSR > 1.063" Brg O.D/ 3.622" Stack-up	A-1	A	PT530
		2 ISR & 2 OSR > 1.063"/1.125" Brg O.D/ 2.555" ISR	A-1	B	PT3188
	All Models-2 Joint Driveshaft; 135" WB	4 OSR > 1.188" Brg O.D./3.622" Stack-up	A-1	A / B	PT578
	All Models-3 Joint Driveshaft	4 ISR > 1.125" Brg O.D./2.555 Stack-up	B-1	A / B / C	PT3105
91-95	All Models-2 Joint Driveshaft; 110" WB	4 ISR > 1.125" Brg O.D./2.555 Stack-up	A-1	A / B	PT3105
	All Models-2 Joint Driveshaft; 120" WB	4 OSR > 1.063" Brg O.D/ 3.622" Stack-up	A-1	A	PT530
		2 ISR & 2 OSR > 1.063"/1.125" Brg O.D/ 2.555" ISR	A-1	B	PT3188
	All Models-2 Joint Driveshaft; 135" WB	4 OSR > 1.188" Brg O.D./3.622" Stack-up	A-1	A / B	PT578
	All Models-3 Joint Driveshaft	4 ISR > 1.125" Brg O.D./2.555 Stack-up	B-1	A / B / C	PT3105

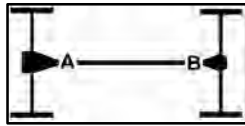

APPLICATION A-1

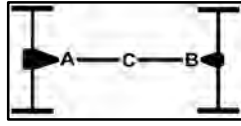

APPLICATION B-1

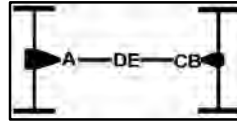

APPLICATION C-1

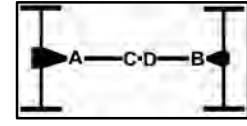

APPLICATION D-1

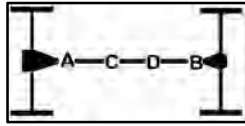

APPLICATION E-1

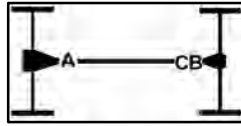

APPLICATION F-1

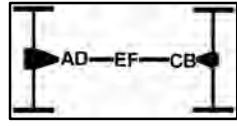

APPLICATION H-1

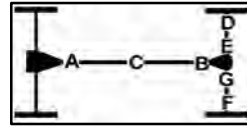

APPLICATION I-1

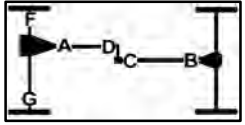

APPLICATION K-1

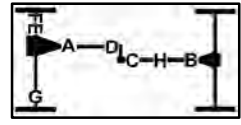

APPLICATION L-1

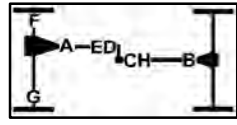

APPLICATION N-1

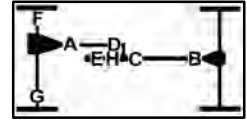

APPLICATION O-1

MAKE/YEARS FITMENT U-JOINT DESCRIPTION LOCATION POSITION PART NO.

GMC

GMC

G1500 1/2 TON VAN 2WD**70-90 All Models-2 Joint Driveshaft**

4 OSR > 1.063" Brg O.D./ 3.217" Stack-up

A-1 A / B PT521HD

4 ISR > 1.125" Brg O.D./2.555 Stack-up

A-1 A / B PT3105

All Models-3 Joint Driveshaft

4 ISR > 1.125" Brg O.D./2.555 Stack-up

B-1 A / B / C PT3105

4 OSR > 1.063" Brg O.D/ 3.217" Stack-up

B-1 A / B / C PT521HD

4 OSR > 1.188" Brg O.D./3.622" Stack-up

B-1 B / C PT578

G2500 3/4 TON VAN 2WD**96-02 All Models-2 or 3 Joint Driveshaft**

4 ISR > 1.125" Brg O.D./2.555 Stack-up

B-1 A / B / C PT3105

4 OSR > 1.188" Brg O.D./3.622" Stack-up

B-1 A / B / C PT578

91-95 All Models-2 Joint Driveshaft

4 ISR > 1.125" Brg O.D./2.555 Stack-up

A-1 A / B PT3105

4 OSR > 1.063" Brg O.D/ 3.622" Stack-up

A-1 A PT530

2 ISR & 2 OSR > 1.063"/1.125" Brg O.D/ 2.555" ISR

A-1 B PT3188

82-90 All Models-2 or 3 Joint Driveshaft

4 ISR > 1.125" Brg O.D./2.555 Stack-up

B-1 A / B / C PT3105

1981 All Models-2 Joint Driveshaft

4 ISR > 1.125" Brg O.D./2.555 Stack-up

A-1 A / B PT3105

4 OSR > 1.063" Brg O.D/ 3.217" Stack-up

A-1 A / B PT521HD

All Models-3 Joint Driveshaft

4 ISR > 1.125" Brg O.D./2.555 Stack-up

B-1 A PT3105

4 OSR > 1.188" Brg O.D./3.622" Stack-up

B-1 B / C PT578

4 OSR > 1.063" Brg O.D/ 3.217" Stack-up

B-1 B / C PT521HD

76-80 All Models-2 Joint Driveshaft; V-8 400 Sm Blk

4 ISR > 1.125" Brg O.D./2.555 Stack-up

A-1 A PT3105

2 ISR & 2 OSR > 1.063"/1.125" Brg O.D/ 2.555" ISR

A-1 B PT3188

All Models-2 or 3 Joint Driveshaft; Exc. V-8 400 Sm Blk

4 OSR > 1.063" Brg O.D/ 3.217" Stack-up

B-1 A / B / C PT521HD

4 ISR > 1.125" Brg O.D./2.555 Stack-up

B-1 A / B / C PT3105

All Models-3 Joint Driveshaft; V-8 400 Sm Blk

4 ISR > 1.125" Brg O.D./2.555 Stack-up

B-1 A PT3105

4 OSR > 1.063" Brg O.D/ 3.622" Stack-up

B-1 B PT530

4 OSR > 1.188" Brg O.D./3.622" Stack-up

B-1 C PT578

70-75 All Models

4 OSR > 1.063" Brg O.D/ 3.217" Stack-up

B-1 A / B / C PT521HD

G3500 1 TON VAN 2WD**96-02 All Models-2 or 3 Joint Driveshaft**

4 OSR > 1.188" Brg O.D./3.622" Stack-up

B-1 A / B / C PT578

4 OSR > 1.188" Brg O.D./4.182" Stack-up

B-1 A / B / C PT560

91-95 All Models-2 or 3 Joint Driveshaft

4 OSR > 1.188" Brg O.D./3.622" Stack-up

B-1 A / B / C PT578

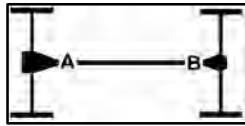

APPLICATION A-1

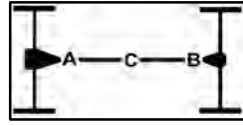

APPLICATION B-1

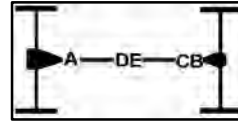

APPLICATION C-1

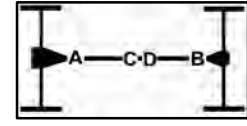

APPLICATION D-1

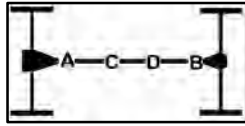

APPLICATION E-1

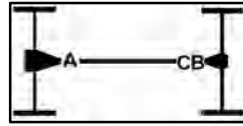

APPLICATION F-1

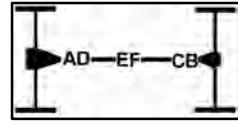

APPLICATION H-1

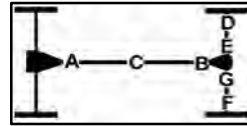

APPLICATION I-1

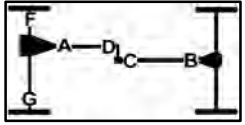

APPLICATION K-1

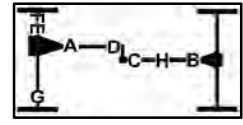

APPLICATION L-1

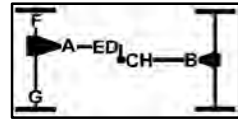

APPLICATION N-1

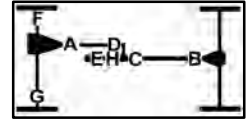

APPLICATION O-1

MAKE/YEARS FITMENT U-JOINT DESCRIPTION LOCATION POSITION PART NO.

GMC

GMC

G3500 1 TON VAN 2WD					
80-90	All Models	4 ISR > 1.125" Brg O.D./2.555 Stack-up	B-1	A	PT3105
		4 OSR > 1.188" Brg O.D./3.622" Stack-up	B-1	A / B / C	PT578
78-79	All Models-2 Joint Driveshaft	4 OSR > 1.188" Brg O.D./3.622" Stack-up	A-1	A / B	PT578
		All Models-3 Joint Driveshaft			
		4 ISR > 1.125" Brg O.D./2.555 Stack-up	B-1	A	PT3105
		4 OSR > 1.188" Brg O.D./3.622" Stack-up	B-1	A / B / C	PT578
75-77	All Models-2 or 3 Joint Driveshaft	4 OSR > 1.063" Brg O.D/ 3.622" Stack-up	B-1	A	PT530
		4 OSR > 1.063" Brg O.D/ 3.217" Stack-up	B-1	A / B	PT521HD
		4 OSR > 1.188" Brg O.D./3.622" Stack-up	B-1	B / C	PT578
70-74	All Models-2 or 3 Joint Driveshaft	4 OSR > 1.063" Brg O.D/ 3.217" Stack-up	B-1	A / B / C	PT521HD
		JIMMY (FULL SIZE) 2WD			
85-93	All Models	4 ISR > 1.125" Brg O.D./2.555 Stack-up	A-1	A / B	PT3105
		4 OSR > 1.188" Brg O.D./3.622" Stack-up	A-1	A / B	PT578
82-84	All Models - 4 Spd. M/T	4 OSR > 1.188" Brg O.D./3.622" Stack-up	A-1	A / B	PT578
		All Models - Exc. 4 Spd. M/T			
		4 ISR > 1.125" Brg O.D./2.555 Stack-up	A-1	A / B	PT3105
		4 OSR > 1.188" Brg O.D./3.622" Stack-up	A-1	A	PT578
70-81	All Models - 4 Spd. M/T	4 OSR > 1.063" Brg O.D/ 3.217" Stack-up	A-1	B	PT521HD
		All Models - Exc. 4 Spd. M/T			
		4 OSR > 1.063" Brg O.D/ 3.217" Stack-up	A-1	A / B	PT521HD
		JIMMY (FULL SIZE) 4WD			
92-93	All Models	4 ISR > 1.125" Brg O.D./2.555 Stack-up	K-1	A / B / C / D	PT3105
		4 OSR > 1.063" Brg O.D/ 3.217" Stack-up	N-1	A	PT521HD
82-91	All Models	4 ISR > 1.125" Brg O.D./2.555 Stack-up	N-1	D / E	PT3105
		All Models - 4 Spd. M/T			
		4 OSR > 1.188" Brg O.D./3.622" Stack-up	N-1	B / C	PT578
		All Models - Exc. 4 Spd. M/T			
		4 ISR > 1.125" Brg O.D./2.555 Stack-up	N-1	B / C	PT3105
		All Models			
		4 OSR > 1.188" Brg O.D./2.187" Stack-up	N-1	F / G	PT297
		4 OSR > 1.063" Brg O.D/ 3.217" Stack-up	N-1	A / B / C	PT521HD
79-81	All Models	4 ISR > 1.125" Brg O.D./2.555 Stack-up	N-1	D / E	PT3105
		4 OSR > 1.188" Brg O.D./2.187" Stack-up	N-1	F / G	PT297

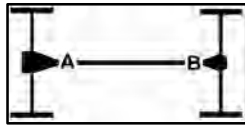

APPLICATION A-1

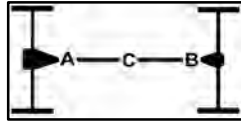

APPLICATION B-1

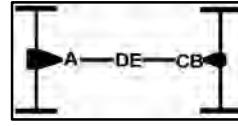

APPLICATION C-1

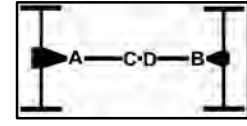

APPLICATION D-1

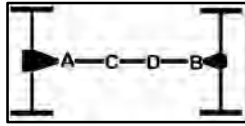

APPLICATION E-1

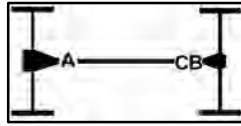

APPLICATION F-1

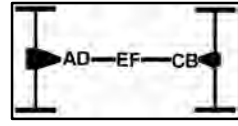

APPLICATION H-1

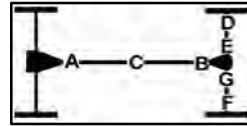

APPLICATION I-1

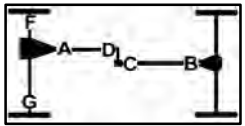

APPLICATION K-1

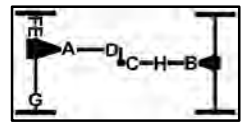

APPLICATION L-1

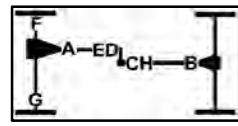

APPLICATION N-1



APPLICATION O-1

MAKE/YEARS FITMENT U-JOINT DESCRIPTION LOCATION POSITION PART NO.

GMC

GMC

JIMMY (FULL SIZE) 4WD**1978 All Models**

4 OSR > 1.063" Brg O.D/ 3.217" Stack-up	N-1	A / B / C / D / E	PT521HD
4 ISR > 1.125" Brg O.D./2.555 Stack-up	N-1	D / E	PT3105
4 ISR > 1.188" Brg O.D./2.187" Stack-up	N-1	F / G	PT297

72-77 All Models

4 OSR > 1.063" Brg O.D/ 3.217" Stack-up	N-1	A / B / C / D / E	PT521HD
4 ISR > 1.188" Brg O.D./2.187" Stack-up	N-1	F / G	PT297

70-71 All Models

4 OSR > 1.063" Brg O.D/ 3.217" Stack-up	N-1	A / B / C / D / E	PT521HD
4 ISR > 1.063" Brg O.D/2.183" Stack-up	N-1	F / G	PT260

K1500 1/2 TON PICKUP 4WD**92-99 All Models - 6.2L or 6.5L DSL**

2 ISR & 2 OSR > 1.063"/1.125" Brg O.D/ 2.555" ISR	L-1	A	PT3188
4 OSR > 1.063" Brg O.D/ 3.622" Stack-up	L-1	D	PT530

All Models - Exc. 6.2L or 6.5L DSL

4 ISR > 1.125" Brg O.D./2.555 Stack-up	L-1	A / D	PT3105
--	-----	-------	--------

All Models - Regular Cab

4 ISR > 1.125" Brg O.D./2.555 Stack-up	L-1	B / C	PT3105
4 OSR > 1.188" Brg O.D./3.622" Stack-up	L-1	B / C	PT578

All Models - Extended Cab

4 OSR > 1.063" Brg O.D/ 3.622" Stack-up	L-1	C / H	PT530
2 ISR & 2 OSR > 1.063"/1.125" Brg O.D/ 2.555" ISR	L-1	B	PT3188
4 OSR > 1.188" Brg O.D./3.622" Stack-up	L-1	C / B / H	PT578

88-91 All Models - A/T

4 ISR > 1.125" Brg O.D./2.555 Stack-up	L-1	A / D	PT3105
--	-----	-------	--------

All Models - M/T

2 ISR & 2 OSR > 1.063"/1.125" Brg O.D/ 2.555" ISR	L-1	A	PT3188
4 OSR > 1.063" Brg O.D/ 3.622" Stack-up	L-1	D	PT530

All Models - Regular Cab A/T

4 ISR > 1.125" Brg O.D./2.555 Stack-up	L-1	B / C	PT3105
--	-----	-------	--------

All Models - Regular Cab M/T

4 OSR > 1.188" Brg O.D./3.622" Stack-up	L-1	B / C	PT578
---	-----	-------	-------

All Models - Extended Cab A/T

4 OSR > 1.063" Brg O.D/ 3.622" Stack-up	L-1	C / H	PT530
2 ISR & 2 OSR > 1.063"/1.125" Brg O.D/ 2.555" ISR	L-1	B	PT3188

All Models - Extended Cab M/T

4 OSR > 1.188" Brg O.D./3.622" Stack-up	L-1	C / B / H	PT578
---	-----	-----------	-------

82-86 All Models

4 OSR > 1.063" Brg O.D/ 3.217" Stack-up	N-1	A	PT521HD
4 ISR > 1.125" Brg O.D./2.555 Stack-up	N-1	B / C / D / E	PT3105
4 OSR > 1.188" Brg O.D./3.622" Stack-up	N-1	B / H	PT578
4 ISR > 1.188" Brg O.D./2.187" Stack-up	N-1	F / G	PT297

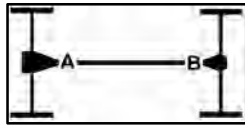

APPLICATION A-1

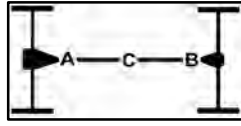

APPLICATION B-1

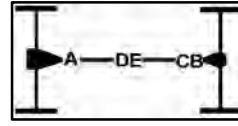

APPLICATION C-1

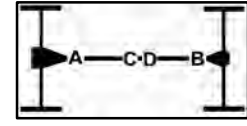

APPLICATION D-1

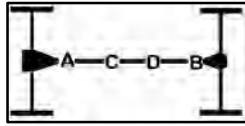

APPLICATION E-1

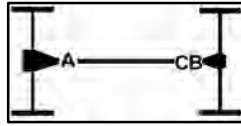

APPLICATION F-1

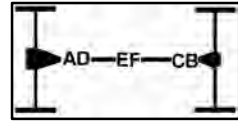

APPLICATION H-1

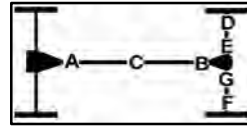

APPLICATION I-1

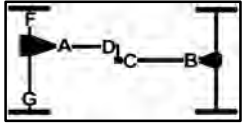

APPLICATION K-1

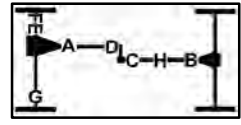

APPLICATION L-1

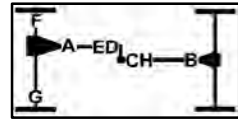

APPLICATION N-1

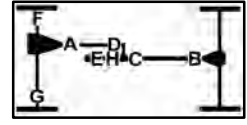

APPLICATION O-1

MAKE/YEARS FITMENT U-JOINT DESCRIPTION LOCATION POSITION PART NO.

GMC

GMC

MAKE/YEARS	FITMENT	U-JOINT DESCRIPTION	LOCATION	POSITION	PART NO.
K1500 1/2 TON PICKUP 4WD					
79-81	All Models	4 ISR > 1.125" Brg O.D./2.555 Stack-up	N-1	D / E	PT3105
		4 OSR > 1.063" Brg O.D/ 3.217" Stack-up	N-1	A / B / C	PT521HD
		4 ISR > 1.188" Brg O.D./2.187" Stack-up	N-1	F / G	PT297
1978	All Models	4 ISR > 1.125" Brg O.D./2.555 Stack-up	N-1	D / E	PT3105
		4 OSR > 1.063" Brg O.D/ 3.217" Stack-up	N-1	A / B / C / D / E	PT521HD
		4 OSR > 1.188" Brg O.D./3.622" Stack-up	N-1	B / H	PT578
		4 ISR > 1.188" Brg O.D./2.187" Stack-up	N-1	F / G	PT297
70-77	All Models	4 OSR > 1.063" Brg O.D/ 3.217" Stack-up	N-1	A / B / C / D / E	PT521HD
		4 ISR > 1.063" Brg O.D/2.183" Stack-up	N-1	F / G	PT260
		4 ISR > 1.188" Brg O.D./2.187" Stack-up	N-1	F / G	PT297
K2500 3/4 TON PICKUP 4WD					
92-99	All Models - 6.2L or 6.5L DSL	2 ISR & 2 OSR > 1.063"/1.125" Brg O.D/ 2.555" ISR	L-1	A	PT3188
		4 OSR > 1.063" Brg O.D/ 3.622" Stack-up	L-1	D	PT530
		All Models - Exc. 6.2L or 6.5L DSL			
		4 ISR > 1.125" Brg O.D./2.555 Stack-up	L-1	A / D	PT3105
	All Models	4 OSR > 1.188" Brg O.D./3.622" Stack-up	L-1	C / B / H	PT578
88-91	All Models - A/T	4 ISR > 1.125" Brg O.D./2.555 Stack-up	L-1	A / D	PT3105
		All Models - M/T			
			2 ISR & 2 OSR > 1.063"/1.125" Brg O.D/ 2.555" ISR	L-1	A
		4 OSR > 1.063" Brg O.D/ 3.622" Stack-up	L-1	D	PT530
	All Models	4 OSR > 1.188" Brg O.D./3.622" Stack-up	L-1	C / B / H	PT578
77-86	All Models	4 ISR > 1.125" Brg O.D./2.555 Stack-up	N-1	D / E	PT3105
		4 OSR > 1.063" Brg O.D/ 3.217" Stack-up	N-1	A / C / D / E	PT521HD
		4 OSR > 1.188" Brg O.D./3.622" Stack-up	N-1	B / C / H	PT578
		4 ISR > 1.188" Brg O.D./2.187" Stack-up	N-1	F / G	PT297
70-76	All Models	4 OSR > 1.063" Brg O.D/ 3.217" Stack-up	N-1	A / B / C / D / E	PT521HD
		4 OSR > 1.188" Brg O.D./3.622" Stack-up	N-1	B / C / H	PT578
		4 ISR > 1.063" Brg O.D/2.183" Stack-up	N-1	F / G	PT260
		4 ISR > 1.188" Brg O.D./2.187" Stack-up	N-1	F / G	PT297
K3500 1 TON PICKUP 4WD					
92-99	All Models	4 ISR > 1.125" Brg O.D./2.555 Stack-up	L-1	A / D	PT3105
		4 OSR > 1.188" Brg O.D./3.622" Stack-up	L-1	C / B / H	PT578

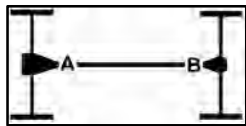

APPLICATION A-1

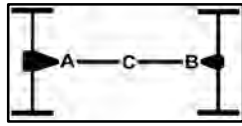

APPLICATION B-1

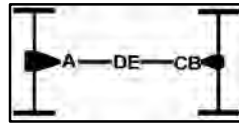

APPLICATION C-1

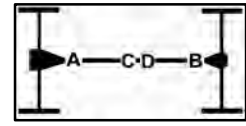

APPLICATION D-1

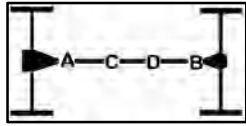

APPLICATION E-1

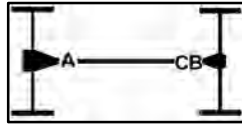

APPLICATION F-1

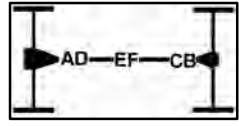

APPLICATION H-1

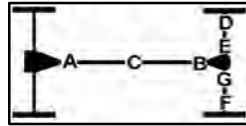

APPLICATION I-1

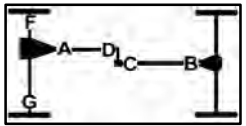

APPLICATION K-1

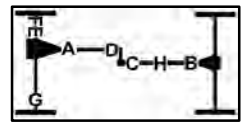

APPLICATION L-1

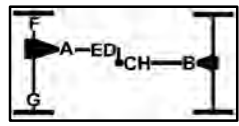

APPLICATION N-1



APPLICATION O-1

MAKE/YEARS FITMENT U-JOINT DESCRIPTION LOCATION POSITION PART NO.

GMC

GMC

K3500 1 TON PICKUP 4WD					
88-91 All Models - 2 Door					
	4 ISR > 1.125" Brg O.D./2.555 Stack-up		N-1	A / D	PT3105
	4 OSR > 1.063" Brg O.D/ 3.622" Stack-up		N-1	D	PT530
	4 OSR > 1.188" Brg O.D./3.622" Stack-up		N-1	C / B / H	PT578
	2 ISR & 2 OSR > 1.063"/1.125" Brg O.D/ 2.555" ISR		N-1	A	PT3188
All Models - 4 Door					
	4 ISR > 1.125" Brg O.D./2.555 Stack-up		N-1	D / E	PT3105
	4 OSR > 1.063" Brg O.D/ 3.217" Stack-up		N-1	A	PT521HD
	4 OSR > 1.188" Brg O.D./3.622" Stack-up		N-1	C / B / H	PT578
All Models					
	4 ISR > 1.375" Brg O.D./2.995" Stack-up		N-1	F / G	PT332
80-86 All Models					
	4 ISR > 1.125" Brg O.D./2.555 Stack-up		N-1	D / E	PT3105
	4 OSR > 1.063" Brg O.D/ 3.217" Stack-up		N-1	A	PT521HD
	4 OSR > 1.188" Brg O.D./3.622" Stack-up		N-1	B / C / H	PT578
	4 ISR > 1.375" Brg O.D./2.995" Stack-up		N-1	F / G	PT332
1979 All Models					
	4 OSR > 1.063" Brg O.D/ 3.217" Stack-up		N-1	C / D / E	PT521HD
	4 OSR > 1.188" Brg O.D./3.622" Stack-up		N-1	A / B / C / H	PT578
	4 ISR > 1.375" Brg O.D./2.995" Stack-up		N-1	F / G	PT332
77-78 All Models					
	4 OSR > 1.063" Brg O.D/ 3.217" Stack-up		L-1	A / D	PT521HD
	4 OSR > 1.188" Brg O.D./3.622" Stack-up		L-1	C / B / H	PT578
	4 ISR > 1.375" Brg O.D./2.995" Stack-up		L-1	F / G	PT332
P1500 1/2 TON VAN 2WD					
70-89 All Models-2 Joint Driveshaft					
	4 OSR > 1.063" Brg O.D/ 3.217" Stack-up		A-1	A / B	PT521HD
	4 ISR > 1.125" Brg O.D./2.555 Stack-up		A-1	A / B	PT3105
All Models-3 Joint Driveshaft					
	4 ISR > 1.125" Brg O.D./2.555 Stack-up		B-1	A / B / C	PT3105
	4 OSR > 1.063" Brg O.D/ 3.217" Stack-up		B-1	A / B / C	PT521HD
	4 OSR > 1.188" Brg O.D./3.622" Stack-up		B-1	B / C	PT578
P2500 3/4 TON VAN 2WD					
82-89 All Models-2 or 3 Joint Driveshaft					
	4 ISR > 1.125" Brg O.D./2.555 Stack-up		B-1	A / B / C	PT3105
1981 All Models-2 Joint Driveshaft					
	4 ISR > 1.125" Brg O.D./2.555 Stack-up		A-1	A / B	PT3105
	4 OSR > 1.063" Brg O.D/ 3.217" Stack-up		A-1	A / B	PT521HD
All Models-3 Joint Driveshaft					
	4 ISR > 1.125" Brg O.D./2.555 Stack-up		B-1	A	PT3105
	4 OSR > 1.188" Brg O.D./3.622" Stack-up		B-1	B / C	PT578
	4 OSR > 1.063" Brg O.D/ 3.217" Stack-up		B-1	B / C	PT521HD

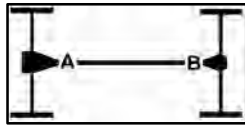

APPLICATION A-1

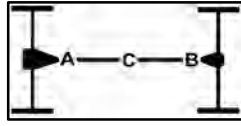

APPLICATION B-1

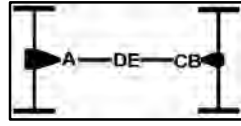

APPLICATION C-1

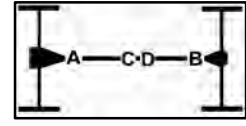

APPLICATION D-1

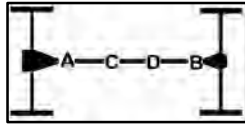

APPLICATION E-1

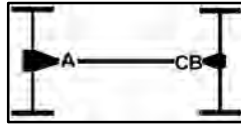

APPLICATION F-1

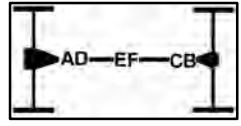

APPLICATION H-1

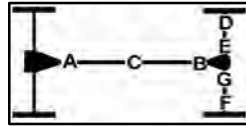

APPLICATION I-1

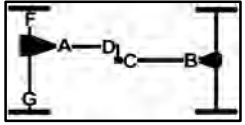

APPLICATION K-1

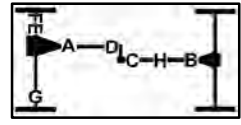

APPLICATION L-1

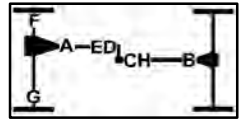

APPLICATION N-1



APPLICATION O-1

MAKE/YEARS FITMENT U-JOINT DESCRIPTION LOCATION POSITION PART NO.

GMC

GMC

MAKE/YEARS	FITMENT	U-JOINT DESCRIPTION	LOCATION	POSITION	PART NO.
P2500 3/4 TON VAN 2WD					
76-80	All Models-2 Joint Driveshaft; V-8 400 Sm Blk	4 ISR > 1.125" Brg O.D./2.555 Stack-up	A-1	A	PT3105
		2 ISR & 2 OSR > 1.063"/1.125" Brg O.D/ 2.555" ISR	A-1	B	PT3188
	All Models-2 or 3 Joint Driveshaft; Exc. V-8 400 Sm Blk	4 OSR > 1.063" Brg O.D/ 3.217" Stack-up	B-1	A / B / C	PT521HD
		4 ISR > 1.125" Brg O.D./2.555 Stack-up	B-1	A / B / C	PT3105
	All Models-3 Joint Driveshaft; V-8 400 Sm Blk	4 ISR > 1.125" Brg O.D./2.555 Stack-up	B-1	A	PT3105
		4 OSR > 1.063" Brg O.D/ 3.622" Stack-up	B-1	B	PT530
		4 OSR > 1.188" Brg O.D./3.622" Stack-up	B-1	C	PT578
70-75	All Models	4 OSR > 1.063" Brg O.D/ 3.217" Stack-up	B-1	A / B / C	PT521HD
P3500 1 TON VAN 2WD					
91-99	All Models-2 or 3 Joint Driveshaft	4 OSR > 1.188" Brg O.D./3.622" Stack-up	B-1	A / B / C	PT578
		4 OSR > 1.188" Brg O.D./4.182" Stack-up	B-1	A / B / C	PT560
80-90	All Models	4 ISR > 1.125" Brg O.D./2.555 Stack-up	B-1	A	PT3105
		4 OSR > 1.188" Brg O.D./3.622" Stack-up	B-1	A / B / C	PT578
78-79	All Models-2 Joint Driveshaft	4 OSR > 1.188" Brg O.D./3.622" Stack-up	A-1	A / B	PT578
	All Models-3 Joint Driveshaft	4 ISR > 1.125" Brg O.D./2.555 Stack-up	B-1	A	PT3105
		4 OSR > 1.188" Brg O.D./3.622" Stack-up	B-1	A / B / C	PT578
75-77	All Models-2 or 3 Joint Driveshaft	4 OSR > 1.063" Brg O.D/ 3.622" Stack-up	B-1	A	PT530
		4 OSR > 1.063" Brg O.D/ 3.217" Stack-up	B-1	A / B	PT521HD
		4 OSR > 1.188" Brg O.D./3.622" Stack-up	B-1	B / C	PT578
70-74	All Models-2 or 3 Joint Driveshaft	4 OSR > 1.063" Brg O.D/ 3.217" Stack-up	B-1	A / B / C	PT521HD
R1500 1/2 TON PICKUP 2WD					
1987	All Models-2 Joint Driveshaft	4 ISR > 1.125" Brg O.D./2.555 Stack-up	A-1	A / B	PT3105
	All Models-3 Joint Driveshaft	4 ISR > 1.125" Brg O.D./2.555 Stack-up	B-1	A / B / C	PT3105
		4 OSR > 1.188" Brg O.D./3.622" Stack-up	B-1	A / B / C	PT578
R2500 3/4 TON PICKUP 2WD					
1987	All Models	4 OSR > 1.188" Brg O.D./3.622" Stack-up	B-1	A / B / C	PT578
		4 ISR > 1.125" Brg O.D./2.555 Stack-up	B-1	A / C	PT3105

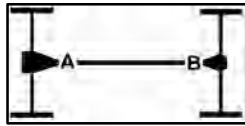

APPLICATION A-1

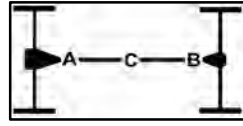

APPLICATION B-1

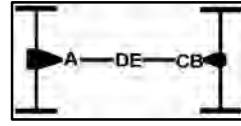

APPLICATION C-1

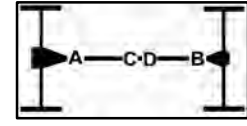

APPLICATION D-1

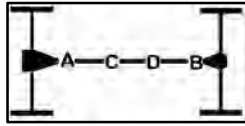

APPLICATION E-1

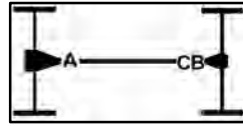

APPLICATION F-1

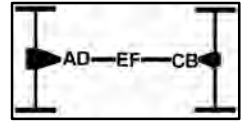

APPLICATION H-1

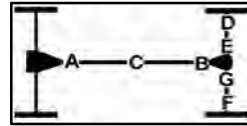

APPLICATION I-1

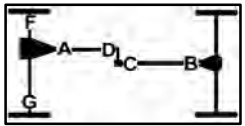

APPLICATION K-1

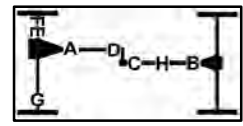

APPLICATION L-1

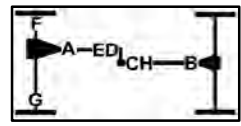

APPLICATION N-1



APPLICATION O-1

MAKE/YEARS FITMENT U-JOINT DESCRIPTION LOCATION POSITION PART NO.

GMC

GMC

MAKE/YEARS	FITMENT	U-JOINT DESCRIPTION	LOCATION	POSITION	PART NO.
R3500 1 TON PICKUP 2WD					
1991	All Models	4 OSR > 1.188" Brg O.D./3.622" Stack-up	B-1	A / B / C	PT578
		4 OSR > 1.188" Brg O.D./4.182" Stack-up	E-1	A / B / C / D	PT560
89-90	All Models	4 OSR > 1.188" Brg O.D./3.622" Stack-up	B-1	A / B / C	PT578
87-88	All Models-3 or 4 Joint Driveshaft	4 OSR > 1.188" Brg O.D./3.622" Stack-up	C-1	A / B / C / D	PT578
S15 JIMMY 2WD					
83-91	All Models	4 ISR > 1.125" Brg O.D./2.555 Stack-up	A-1	A / B	PT3105
S15 JIMMY 4WD					
88-91	All Models - Press On Slip Yoke	2 ISR & 2 OSR > 1.063" Brg O.D/ 3.217" OSR - 2.188" ISR Stack-up	L-1	A	PT455
		4 OSR > 1.063" Brg O.D/ 3.217" Stack-up	L-1	D	PT521HD
All Models - Screw On Slip Yoke	All Models	2 ISR & 2 OSR > 1.063" Brg O.D/ 3.217" OSR - 2.344" ISR Stack-up	L-1	A / D	PT445
		4 ISR > 1.125" Brg O.D./2.555 Stack-up	L-1	B / C	PT3105
83-87	All Models	2 ISR & 2 OSR > 1.063" Brg O.D/ 3.217" OSR - 2.344" ISR Stack-up	L-1	A / D	PT445
		4 ISR > 1.125" Brg O.D./2.555 Stack-up	L-1	B / C	PT3105
S15 PICKUP 2WD					
82-90	All Models - Short Bed	4 ISR > 1.125" Brg O.D./2.555 Stack-up	A-1	A / B	PT3105
		All Models - Exc. Short Bed	B-1	A / B / C	PT3105
S15 PICKUP 4WD					
88-90	All Models - Press On Slip Yoke	2 ISR & 2 OSR > 1.063" Brg O.D/ 3.217" OSR - 2.188" ISR Stack-up	L-1	A	PT455
		4 OSR > 1.063" Brg O.D/ 3.217" Stack-up	L-1	D	PT521HD
All Models - Screw On Slip Yoke	All Models	2 ISR & 2 OSR > 1.063" Brg O.D/ 3.217" OSR - 2.344" ISR Stack-up	L-1	A / D	PT445
		4 ISR > 1.125" Brg O.D./2.555 Stack-up	L-1	B / C / H	PT3105
82-87	All Models	2 ISR & 2 OSR > 1.063" Brg O.D/ 3.217" OSR - 2.344" ISR Stack-up	L-1	A / D	PT445
		4 ISR > 1.125" Brg O.D./2.555 Stack-up	L-1	B / C / H	PT3105
SAFARI VAN FWD					
03-05	All Models	4 ISR > 1.125" Brg O.D./2.555 Stack-up	A-1	A / B	PT3105

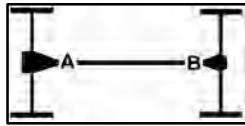

APPLICATION A-1

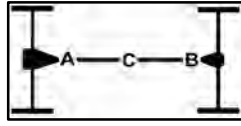

APPLICATION B-1

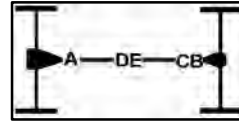

APPLICATION C-1

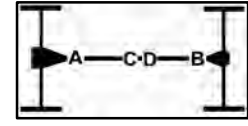

APPLICATION D-1

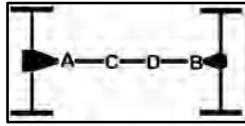

APPLICATION E-1

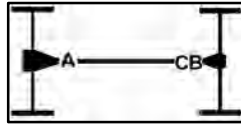

APPLICATION F-1

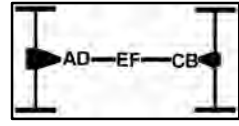

APPLICATION H-1

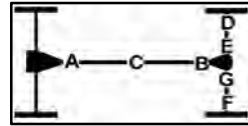

APPLICATION I-1

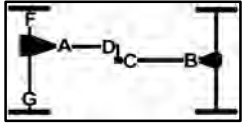

APPLICATION K-1

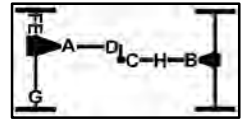

APPLICATION L-1

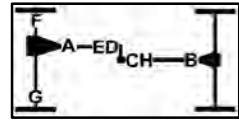

APPLICATION N-1



APPLICATION O-1

MAKE/YEARS FITMENT U-JOINT DESCRIPTION LOCATION POSITION PART NO.

GMC

GMC

MAKE/YEARS	FITMENT	U-JOINT DESCRIPTION	LOCATION	POSITION	PART NO.
SAFARI VAN FWD					
85-02	All Models	4 ISR > 1.125" Brg O.D./2.555 Stack-up	A-1	A	PT3105
		4 OSR > 1.188" Brg O.D./3.622" Stack-up	A-1	B	PT578
SAFARI VAN AWD					
90-05	All Models	4 ISR > 1.125" Brg O.D./2.555 Stack-up	L-1	B / C	PT3105
		4 OSR > 1.188" Brg O.D./3.622" Stack-up	L-1	B	PT578
SAVANA 1500 1/2 TON VAN 2WD					
03-06	All Models	4 OSR > 1.188" Brg O.D./3.622" Stack-up	A-1	A / B	PT578
SAVANA 1500 1/2 TON VAN 4WD					
03-06	All Models	4 ISR > 1.125" Brg O.D./2.555 Stack-up	K-1	A / D	PT3105
		4 OSR > 1.188" Brg O.D./3.622" Stack-up	K-1	B / C	PT578
SAVANA 2500 3/4 TON VAN 2WD					
03-06	All Models-2 Joint Driveshaft	4 OSR > 1.188" Brg O.D./3.622" Stack-up	A-1	A / B	PT578
	All Models-3 Joint Driveshaft	4 OSR > 1.188" Brg O.D./3.622" Stack-up	B-1	A / B / C	PT578
SAVANA 2500 3/4 TON VAN 4WD					
03-06	All Models	4 ISR > 1.125" Brg O.D./2.555 Stack-up	K-1	A / B / C / D	PT3105
		4 OSR > 1.188" Brg O.D./3.622" Stack-up	K-1	B / C	PT578
SAVANA 3500 1 TON VAN 2WD					
03-06	All Models-2 or 3 Joint Driveshaft	4 OSR > 1.188" Brg O.D./3.622" Stack-up	B-1	A / B / C	PT578
SIERRA 1500 1/2 TON PICKUP 2WD					
00-06	All Models w/ Regular Cab	4 ISR > 1.125" Brg O.D./2.555 Stack-up	A-1	A / B	PT3105
		4 OSR > 1.063" Brg O.D./ 3.622" Stack-up	A-1	A	PT530
		2 ISR & 2 OSR > 1.063"/1.125" Brg O.D/ 2.555" ISR	A-1	B	PT3188
	All Models w/ Extended Cab	4 ISR > 1.125" Brg O.D./2.555 Stack-up	B-1	A / B / C	PT3105
		4 OSR > 1.063" Brg O.D/ 3.622" Stack-up	B-1	A / C	PT530
		2 ISR & 2 OSR > 1.063"/1.125" Brg O.D/ 2.555" ISR	B-1	B	PT3188

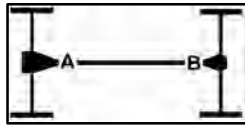

APPLICATION A-1

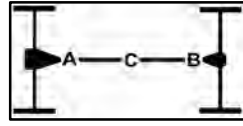

APPLICATION B-1

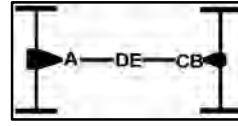

APPLICATION C-1

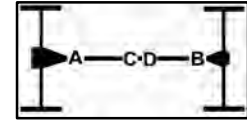

APPLICATION D-1

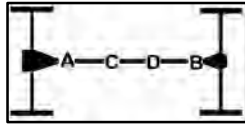

APPLICATION E-1

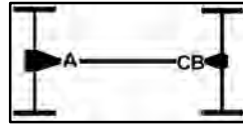

APPLICATION F-1

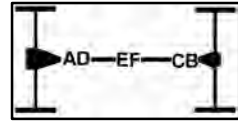

APPLICATION H-1

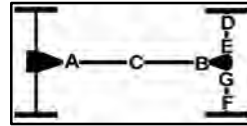

APPLICATION I-1

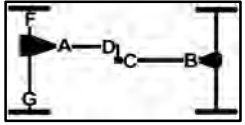

APPLICATION K-1

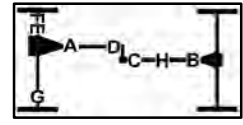

APPLICATION L-1

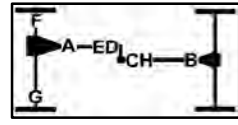

APPLICATION N-1

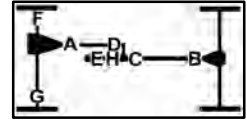

APPLICATION O-1

MAKE/YEARS FITMENT U-JOINT DESCRIPTION LOCATION POSITION PART NO.

GMC

GMC

MAKE/YEARS	FITMENT	U-JOINT DESCRIPTION	LOCATION	POSITION	PART NO.
SIERRA 1500 1/2 TON PICKUP 4WD					
05-06	All Models - Regular Cab	4 ISR > 1.125" Brg O.D./2.555 Stack-up	L-1	A / D	PT3105
		4 OSR > 1.188" Brg O.D./3.622" Stack-up	L-1	B / C	PT578
	All Models - Extended Cab	4 ISR > 1.125" Brg O.D./2.555 Stack-up	L-1	A / D	PT3105
		4 OSR > 1.188" Brg O.D./3.622" Stack-up	L-1	B / C / H	PT578
		4 OSR > 1.063" Brg O.D./ 3.622" Stack-up	L-1	C / H	PT530
		2 ISR & 2 OSR > 1.063"/1.125" Brg O.D/ 2.555" ISR	L-1	B	PT3188
02-04	All Models - Regular Cab	4 ISR > 1.125" Brg O.D./2.555 Stack-up	L-1	A / B / C / D	PT3105
	All Models - Extended Cab	4 ISR > 1.125" Brg O.D./2.555 Stack-up	L-1	A / D	PT3105
		2 ISR & 2 OSR > 1.063"/1.125" Brg O.D/ 2.555" ISR	L-1	B	PT3188
		4 OSR > 1.188" Brg O.D./3.622" Stack-up	L-1	B / C	PT578
		4 OSR > 1.063" Brg O.D/ 3.622" Stack-up	L-1	C / H	PT530
00-01	All Models - Regular Cab	4 ISR > 1.125" Brg O.D./2.555 Stack-up	L-1	A / B / C / D	PT3105
	All Models - Extended Cab	4 ISR > 1.125" Brg O.D./2.555 Stack-up	L-1	A / D	PT3105
		2 ISR & 2 OSR > 1.063"/1.125" Brg O.D/ 2.555" ISR	L-1	B	PT3188
		4 OSR > 1.063" Brg O.D/ 3.622" Stack-up	L-1	C / H	PT530
SIERRA 2500 3/4 TON PICKUP 2WD					
02-04	All Models	4 OSR > 1.188" Brg O.D./3.622" Stack-up	B-1	A / B / C	PT578
00-01	All Models-3 Joint Driveshaft	4 OSR > 1.188" Brg O.D./4.182" Stack-up	B-1	A / B / C	PT560
		4 OSR > 1.188" Brg O.D./3.622" Stack-up	B-1	A / B / C	PT578
SIERRA 2500 3/4 TON PICKUP 4WD					
01-04	All Models	4 ISR > 1.125" Brg O.D./2.555 Stack-up	L-1	A / D	PT3105
		4 OSR > 1.188" Brg O.D./3.622" Stack-up	L-1	B / C	PT578
2000	All Models	4 ISR > 1.125" Brg O.D./2.555 Stack-up	L-1	A / D	PT3105
		4 OSR > 1.188" Brg O.D./4.182" Stack-up	L-1	B / C	PT560
		4 OSR > 1.188" Brg O.D./3.622" Stack-up	L-1	B / C / H	PT578
SIERRA 2500HD 3/4 TON PICKUP 2WD					
01-06	All Models	4 OSR > 1.188" Brg O.D./4.182" Stack-up	B-1	A / B / C	PT560
		4 OSR > 1.375" Brg O.D./4.182" Stack-up	B-1	A / B / C	PT588

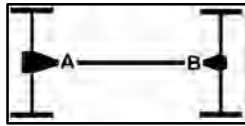

APPLICATION A-1

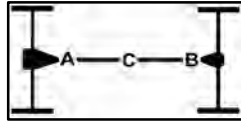

APPLICATION B-1

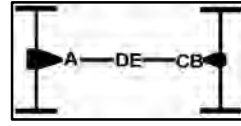

APPLICATION C-1

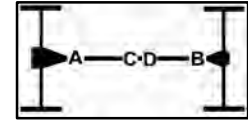

APPLICATION D-1

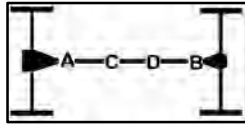

APPLICATION E-1

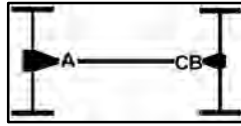

APPLICATION F-1

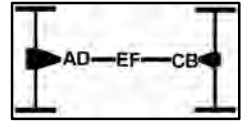

APPLICATION H-1

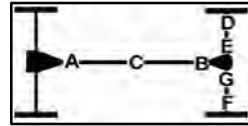

APPLICATION I-1

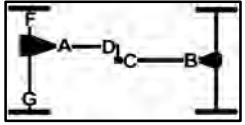

APPLICATION K-1

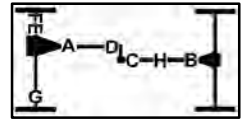

APPLICATION L-1

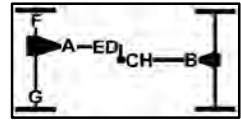

APPLICATION N-1



APPLICATION O-1

MAKE/YEARS FITMENT U-JOINT DESCRIPTION LOCATION POSITION PART NO.

GMC

GMC

MAKE/YEARS	FITMENT	U-JOINT DESCRIPTION	LOCATION	POSITION	PART NO.
SIERRA 2500HD 3/4 TON PICKUP 4WD					
01-06	All Models	4 ISR > 1.125" Brg O.D./2.555 Stack-up	L-1	A / D	PT3105
		4 OSR > 1.188" Brg O.D./4.182" Stack-up	L-1	B / C / H	PT560
		4 OSR > 1.375" Brg O.D./4.182" Stack-up	L-1	B / C / H	PT588
SIERRA 3500 1 TON PICKUP 2WD					
01-06	All Models	4 OSR > 1.188" Brg O.D./4.182" Stack-up	B-1	A / B / C	PT560
		4 OSR > 1.375" Brg O.D./4.182" Stack-up	B-1	A / B / C	PT588
SIERRA 3500 1 TON PICKUP 4WD					
01-06	All Models	4 ISR > 1.125" Brg O.D./2.555 Stack-up	L-1	A / D	PT3105
		4 OSR > 1.188" Brg O.D./4.182" Stack-up	L-1	B / C / H	PT560
		4 OSR > 1.375" Brg O.D./4.182" Stack-up	L-1	B / C / H	PT588
SONOMA PICKUP 2WD					
97-04	All Models - Regular & Extended Cab	4 ISR > 1.125" Brg O.D./2.555 Stack-up	B-1	A / B / C	PT3105
94-96	All Models - Regular Cab; Short Bed	4 ISR > 1.125" Brg O.D./2.555 Stack-up	A-1	A / B	PT3105
	All Models - Regular Cab; Long Bed	4 OSR > 1.063" Brg O.D/ 3.622" Stack-up	A-1	A	PT530
		2 ISR & 2 OSR > 1.063"/1.125" Brg O.D/ 2.555" ISR	A-1	B	PT3188
	All Models - Extended Cab	4 ISR > 1.125" Brg O.D./2.555 Stack-up	B-1	A / B / C	PT3105
91-93	All Models - Short Bed	4 ISR > 1.125" Brg O.D./2.555 Stack-up	A-1	A / B	PT3105
	All Models - Exc. Short Bed	4 ISR > 1.125" Brg O.D./2.555 Stack-up	B-1	A / B / C	PT3105
SONOMA PICKUP 4WD					
97-04	All Models	2 ISR & 2 OSR > 1.063" Brg O.D/ 3.217" OSR - 2.344" ISR Stack-up	L-1	A	PT445
		4 ISR > 1.125" Brg O.D./2.555 Stack-up	L-1	B / C	PT3105
95-96	All Models	2 ISR & 2 OSR > 1.063" Brg O.D/ 3.217" OSR - 2.344" ISR Stack-up	L-1	A	PT445
	All Models - Sport Package	2 ISR & 2 OSR > 1.063"/1.125" Brg O.D/ 2.555" ISR	L-1	B	PT3188
		4 OSR > 1.063" Brg O.D/ 3.622" Stack-up	L-1	C	PT530
	All Models - Exc. Sport Package	4 ISR > 1.125" Brg O.D./2.555 Stack-up	L-1	B / C	PT3105

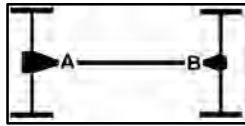

APPLICATION A-1

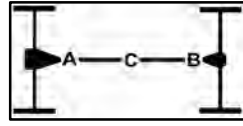

APPLICATION B-1

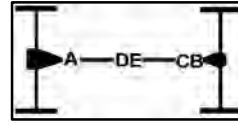

APPLICATION C-1

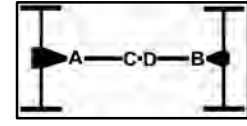

APPLICATION D-1

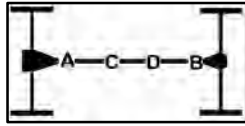

APPLICATION E-1

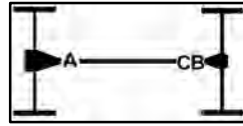

APPLICATION F-1

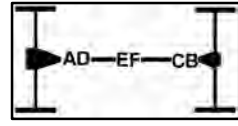

APPLICATION H-1

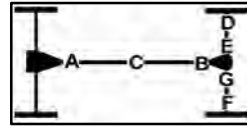

APPLICATION I-1

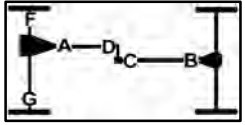

APPLICATION K-1

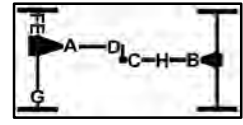

APPLICATION L-1

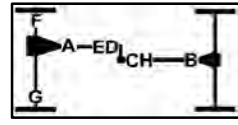

APPLICATION N-1

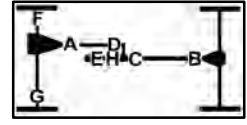

APPLICATION O-1

MAKE/YEARS FITMENT U-JOINT DESCRIPTION LOCATION POSITION PART NO.

GMC

GMC

MAKE/YEARS	FITMENT	U-JOINT DESCRIPTION	LOCATION	POSITION	PART NO.
SONOMA PICKUP 4WD					
91-94	All Models	Press On Slip Yoke			
		2 ISR & 2 OSR > 1.063" Brg O.D/ 3.217" OSR - 2.188" ISR Stack-up	L-1	A	PT455
		4 OSR > 1.063" Brg O.D/ 3.217" Stack-up	L-1	D	PT521HD
		Screw On Slip Yoke			
		2 ISR & 2 OSR > 1.063" Brg O.D/ 3.217" OSR - 2.344" ISR Stack-up	L-1	A / D	PT445
	All Models	4 ISR > 1.125" Brg O.D./2.555 Stack-up	L-1	B / C / H	PT3105
SPRINT					
73-77	All Models				
		4 ISR > 1.125" Brg O.D./2.555 Stack-up	A-1	A / B	PT3105
		4 OSR > 1.063" Brg O.D/ 3.217" Stack-up	A-1	A / B	PT521HD
71-72	All Models				
		4 OSR > 1.063" Brg O.D/ 3.217" Stack-up	A-1	A / B	PT521HD
V1500 1/2 TON PICKUP 4WD					
1987	All Models				
		4 OSR > 1.063" Brg O.D/ 3.217" Stack-up	N-1	A	PT521HD
		4 ISR > 1.125" Brg O.D./2.555 Stack-up	N-1	B / C / D / E	PT3105
		4 OSR > 1.188" Brg O.D./3.622" Stack-up	N-1	B / C	PT578
		4 ISR > 1.188" Brg O.D./2.187" Stack-up	N-1	F / G	PT297
V2500 3/4 TON PICKUP 4WD					
1987	All Models				
		4 OSR > 1.063" Brg O.D/ 3.217" Stack-up	N-1	A	PT521HD
		4 ISR > 1.125" Brg O.D./2.555 Stack-up	N-1	D / E	PT3105
		4 OSR > 1.188" Brg O.D./3.622" Stack-up	N-1	B / C	PT578
		4 ISR > 1.188" Brg O.D./2.187" Stack-up	N-1	F / G	PT297
V3500 1 TON PICKUP 4WD					
89-91	All Models	2 Door			
		4 ISR > 1.125" Brg O.D./2.555 Stack-up	N-1	A / D	PT3105
		4 OSR > 1.063" Brg O.D/ 3.622" Stack-up	N-1	D	PT530
		4 OSR > 1.188" Brg O.D./3.622" Stack-up	N-1	C / B / H	PT578
		2 ISR & 2 OSR > 1.063"/1.125" Brg O.D/ 2.555" ISR	N-1	A	PT3188
		4 Door			
		4 ISR > 1.125" Brg O.D./2.555 Stack-up	N-1	D / E	PT3105
		4 OSR > 1.063" Brg O.D/ 3.217" Stack-up	N-1	A	PT521HD
		4 OSR > 1.188" Brg O.D./3.622" Stack-up	N-1	C / B / H	PT578
	All Models	4 ISR > 1.375" Brg O.D./2.995" Stack-up	N-1	F / G	PT332

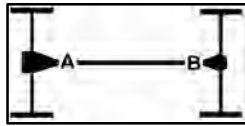

APPLICATION A-1

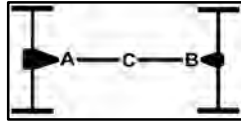

APPLICATION B-1

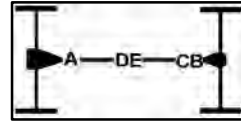

APPLICATION C-1

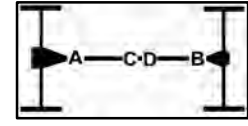

APPLICATION D-1

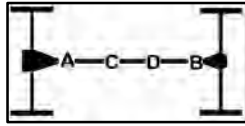

APPLICATION E-1

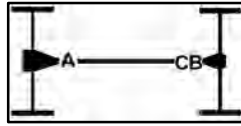

APPLICATION F-1

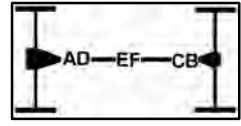

APPLICATION H-1

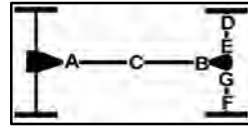

APPLICATION I-1

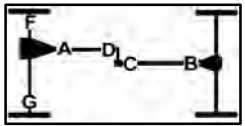

APPLICATION K-1

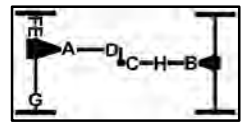

APPLICATION L-1

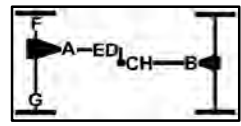

APPLICATION N-1



APPLICATION O-1

MAKE/YEARS FITMENT U-JOINT DESCRIPTION LOCATION POSITION PART NO.

GMC

GMC

MAKE/YEARS	FITMENT	U-JOINT DESCRIPTION	LOCATION	POSITION	PART NO.
V3500 1 TON PICKUP 4WD					
1988	All Models - 2 Door	4 ISR > 1.125" Brg O.D./2.555 Stack-up	N-1	A / D	PT3105
		4 OSR > 1.063" Brg O.D/ 3.622" Stack-up	N-1	D	PT530
		4 OSR > 1.188" Brg O.D./3.622" Stack-up	N-1	C / B / H	PT578
		2 ISR & 2 OSR > 1.063"/1.125" Brg O.D/ 2.555" ISR	N-1	A	PT3188
	All Models - 4 Door	4 ISR > 1.125" Brg O.D./2.555 Stack-up	N-1	D / E	PT3105
		4 OSR > 1.063" Brg O.D/ 3.217" Stack-up	N-1	A	PT521HD
		4 OSR > 1.188" Brg O.D./3.622" Stack-up	N-1	C / B / H	PT578
	All Models	4 ISR > 1.375" Brg O.D./2.995" Stack-up	N-1	F / G	PT332
1987	All Models	4 OSR > 1.063" Brg O.D/ 3.217" Stack-up	N-1	C	PT521HD
		4 OSR > 1.188" Brg O.D./3.622" Stack-up	N-1	C / B / H	PT578
		4 ISR > 1.125" Brg O.D./2.555 Stack-up	N-1	D / E	PT3105
		4 ISR > 1.375" Brg O.D./2.995" Stack-up	N-1	F / G	PT332
YUKON 2WD					
92-07	All Models	4 OSR > 1.063" Brg O.D/ 3.217" Stack-up	A-1	A / B	PT521HD
YUKON 4WD					
92-07	All Models	4 OSR > 1.063" Brg O.D/ 3.217" Stack-up	L-1	A / B / C / D	PT521HD
YUKON DENALI 2WD					
99-00	All Models	4 OSR > 1.063" Brg O.D/ 3.217" Stack-up	A-1	A / B	PT521HD
YUKON DENALI 4WD					
99-00	All Models	4 OSR > 1.063" Brg O.D/ 3.217" Stack-up	L-1	A / B / C / D	PT521HD
YUKON XL1500 2WD					
00-06	All Models w/ Regular Cab	4 ISR > 1.125" Brg O.D./2.555 Stack-up	A-1	A / B	PT3105
		4 OSR > 1.063" Brg O.D/ 3.622" Stack-up	A-1	A	PT530
		2 ISR & 2 OSR > 1.063"/1.125" Brg O.D/ 2.555" ISR	A-1	B	PT3188
	All Models w/ Extended Cab	4 ISR > 1.125" Brg O.D./2.555 Stack-up	B-1	A / B / C	PT3105
		4 OSR > 1.063" Brg O.D/ 3.622" Stack-up	B-1	A / C	PT530
		2 ISR & 2 OSR > 1.063"/1.125" Brg O.D/ 2.555" ISR	B-1	B	PT3188

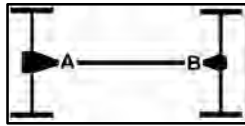

APPLICATION A-1

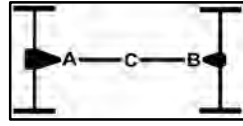

APPLICATION B-1

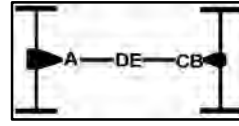

APPLICATION C-1

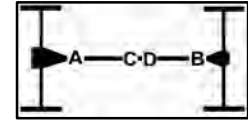

APPLICATION D-1

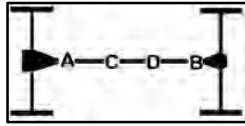

APPLICATION E-1

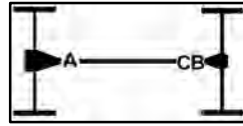

APPLICATION F-1

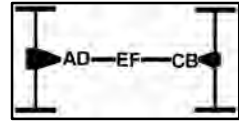

APPLICATION H-1

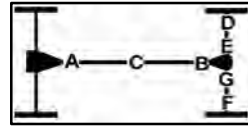

APPLICATION I-1

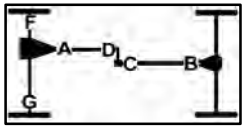

APPLICATION K-1

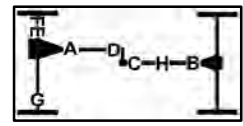

APPLICATION L-1

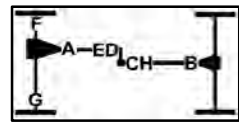

APPLICATION N-1



APPLICATION O-1

MAKE/YEARS FITMENT U-JOINT DESCRIPTION LOCATION POSITION PART NO.

GMC

GMC

YUKON XL1500 4WD					
05-06 All Models - Regular Cab	4 ISR > 1.125" Brg O.D./2.555 Stack-up	L-1	A / D	PT3105	
	4 OSR > 1.188" Brg O.D./3.622" Stack-up	L-1	B / C	PT578	
	All Models - Extended Cab				
	4 ISR > 1.125" Brg O.D./2.555 Stack-up	L-1	A / D	PT3105	
	4 OSR > 1.188" Brg O.D./3.622" Stack-up	L-1	B / C / H	PT578	
	4 OSR > 1.063" Brg O.D/ 3.622" Stack-up	L-1	C / H	PT530	
	2 ISR & 2 OSR > 1.063"/1.125" Brg O.D/ 2.555" ISR	L-1	B	PT3188	
	02-04 All Models - Regular Cab				
	4 ISR > 1.125" Brg O.D./2.555 Stack-up	L-1	A / B / C / D	PT3105	
	All Models - Extended Cab				
4 ISR > 1.125" Brg O.D./2.555 Stack-up	L-1	A / D	PT3105		
2 ISR & 2 OSR > 1.063"/1.125" Brg O.D/ 2.555" ISR	L-1	B	PT3188		
4 OSR > 1.188" Brg O.D./3.622" Stack-up	L-1	B / C	PT578		
4 OSR > 1.063" Brg O.D/ 3.622" Stack-up	L-1	C / H	PT530		
00-01 All Models - Regular Cab					
4 ISR > 1.125" Brg O.D./2.555 Stack-up	L-1	A / B / C / D	PT3105		
All Models - Extended Cab					
4 ISR > 1.125" Brg O.D./2.555 Stack-up	L-1	A / D	PT3105		
2 ISR & 2 OSR > 1.063"/1.125" Brg O.D/ 2.555" ISR	L-1	B	PT3188		
4 OSR > 1.063" Brg O.D/ 3.622" Stack-up	L-1	C / H	PT530		

HONDA

HONDA

PASSPORT 2WD					
94-02 All Models - 2 or 3 Joint Drive Shaft	4 OSR > 1.063" Brg O.D/ 3.217" Stack-up	B-1	A / B / C	PT521HD	
	PASSPORT 4WD				
98-02 All Models	4 OSR > 1.063" Brg O.D/ 3.217" Stack-up	L-1	A / B / C / D	PT521HD	
	94-97 All Models				
	4 ISR > 1.142" Brg O.D./2.089" Stack-up	L-1	A / D	PT1621	
	4 OSR > 1.063" Brg O.D/ 3.217" Stack-up	L-1	B / C / H	PT521HD	

HUMMER

HUMMER

H2 4WD					
03-06 All Models	4 ISR > 1.125" Brg O.D./2.555 Stack-up	L-1	A / D	PT3105	
	4 OSR > 1.188" Brg O.D./3.622" Stack-up	L-1	B / C	PT578	

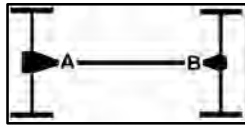

APPLICATION A-1

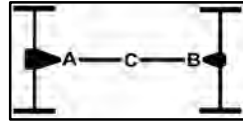

APPLICATION B-1

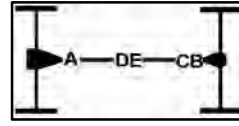

APPLICATION C-1

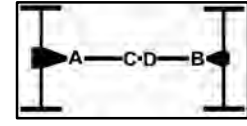

APPLICATION D-1

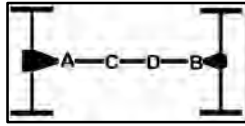

APPLICATION E-1

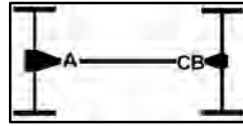

APPLICATION F-1

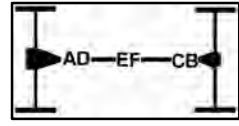

APPLICATION H-1

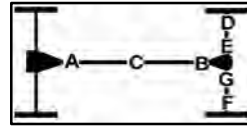

APPLICATION I-1

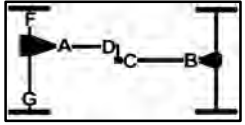

APPLICATION K-1

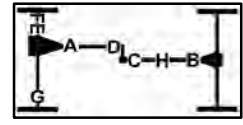

APPLICATION L-1

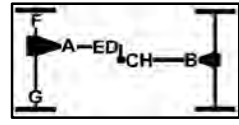

APPLICATION N-1

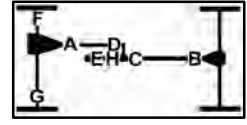

APPLICATION O-1

MAKE/YEARS FITMENT U-JOINT DESCRIPTION LOCATION POSITION PART NO.

HUMMER

HUMMER

H3 4WD					
2006		2 ISR & 2 OSR > 1.063" Brg O.D/ 3.217" OSR - 2.344" ISR Stack-up	L-1	A	PT445
		4 OSR > 1.188" Brg O.D./3.622" Stack-up	L-1	B / C	PT578

INFINITI

INFINITI

QX4 2WD					
00-03	All Models	4 ISR > 1.102" Brg O.D./2.205" Stack-up	A-1	A / B	PT1602
QX4 4WD					
97-03	All Models	4 ISR > 1.063" Brg O.D./1.930 Stack-up	L-1	A / D	PT446
		4 ISR > 1.102" Brg O.D./2.205" Stack-up	L-1	B / C	PT1602
QX56 2WD					
04-07	All Models	4 OSR > 1.188" Brg O.D./3.622" Stack-up	B-1	A / B / C	PT578
QX56 4WD					
04-07	All Models	4 OSR > 1.188" Brg O.D./3.622" Stack-up	L-1	B / C	PT578

ISUZU

ISUZU

AMIGO 2WD					
98-00	All Models	4 OSR > 1.063" Brg O.D/ 3.217" Stack-up	A-1	A / B	PT521HD
89-94	All Models	4 ISR > 1.142" Brg O.D./2.089" Stack-up	A-1	A / B	PT1621
AMIGO 4WD					
98-00	All Models	4 OSR > 1.063" Brg O.D/ 3.217" Stack-up	L-1	A / B / C / D / H	PT521HD
89-94	All Models	4 ISR > 1.142" Brg O.D./2.089" Stack-up	L-1	A / B / C / D / H	PT1621
ASCENDER 2WD					
03-07	All Models	4 ISR > 1.125" Brg O.D./2.555 Stack-up	A-1	A / B	PT3105
ASCENDER 4WD					
03-07	All Models	2 ISR & 2 OSR > 1.063" Brg O.D/ 3.217" OSR - 2.344" ISR Stack-up	K-1	A	PT445
		4 ISR > 1.125" Brg O.D./2.555 Stack-up	K-1	B / C	PT3105

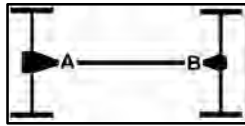

APPLICATION A-1

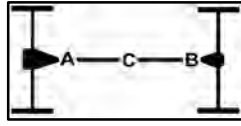

APPLICATION B-1

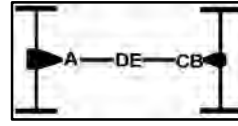

APPLICATION C-1

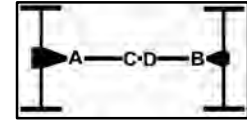

APPLICATION D-1

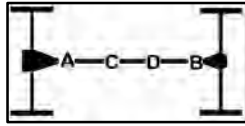

APPLICATION E-1

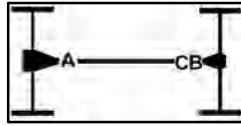

APPLICATION F-1

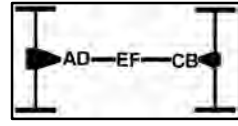

APPLICATION H-1

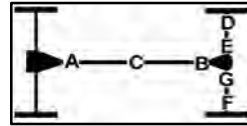

APPLICATION I-1

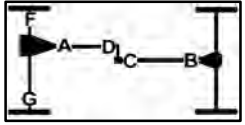

APPLICATION K-1

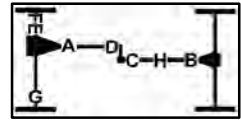

APPLICATION L-1

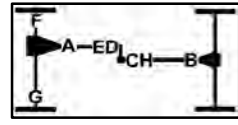

APPLICATION N-1

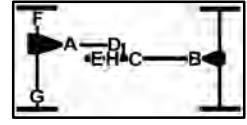

APPLICATION O-1

MAKE/YEARS FITMENT U-JOINT DESCRIPTION LOCATION POSITION PART NO.

ISUZU

ISUZU

MAKE/YEARS	FITMENT	U-JOINT DESCRIPTION	LOCATION	POSITION	PART NO.
AXIOM 2WD					
02-04	All Models	4 OSR > 1.063" Brg O.D/ 3.217" Stack-up	A-1	A / B	PT521HD
AXIOM 4WD					
02-04	All Models	4 OSR > 1.063" Brg O.D/ 3.217" Stack-up	K-1	B / C	PT521HD
HOMBRE 2WD					
96-00	All Models - 2 or 3 Joint Drive Shaft	4 ISR > 1.125" Brg O.D./2.555 Stack-up	A-1	A / B	PT3105
HOMBRE 4WD					
98-00	All Models	2 ISR & 2 OSR > 1.063" Brg O.D/ 3.217" OSR - 2.344" ISR Stack-up	K-1	A	PT445
		4 ISR > 1.125" Brg O.D./2.555 Stack-up	K-1	B / C	PT3105
96-97	All Models	4 ISR > 1.125" Brg O.D./2.555 Stack-up	K-1	B / C	PT3105
PICKUP 2WD					
88-95	All Models	4 ISR > 1.142" Brg O.D./2.089" Stack-up	B-1	A / B / C	PT1621
		4 OSR > 1.063" Brg O.D/ 3.217" Stack-up	B-1	A / B / C	PT521HD
86-87	All Models - 1.9L - 2 or 3 Joint Drive Shaft	4 OSR > .938" Brg O.D./2.407" Stack-up	B-1	A / B / C	PT514
	All Models - 2.3L - 2 or 3 Joint Drive Shaft	4 OSR > .938" Brg O.D./2.407" Stack-up	B-1	A / C	PT514
		4 ISR > 1.142" Brg O.D./2.089" Stack-up	B-1	B	PT1621
	All Models - 2.2L Dsl Turbo - 2 or 3 Joint Drive Shaft	4 OSR > .938" Brg O.D./2.407" Stack-up	B-1	A / C	PT514
		4 ISR > 1.142" Brg O.D./2.089" Stack-up	B-1	B	PT1621
	All Models - 2.2L Dsl Exc. Turbo - 2 or 3 Joint Drive Shaft	4 OSR > .938" Brg O.D./2.407" Stack-up	B-1	A / B / C	PT514
81-85	All Models - 2 or 3 Joint Drive Shaft	4 OSR > .938" Brg O.D./2.407" Stack-up	B-1	A / B / C	PT514
PICKUP 4WD					
81-95	All Models	4 ISR > 1.142" Brg O.D./2.089" Stack-up	L-1	A / D	PT1621
		4 ISR > 1.142" Brg O.D./2.089" Stack-up	L-1	B / C / H	PT1621
		4 OSR > 1.063" Brg O.D/ 3.217" Stack-up	L-1	B / C / H	PT521HD
88-90	All Models	4 ISR > 1.142" Brg O.D./2.089" Stack-up	L-1	A / B / C / D / H	PT1621
81-87	All Models	4 OSR > .938" Brg O.D./2.407" Stack-up	L-1	B / D	PT514
		4 ISR > 1.142" Brg O.D./2.089" Stack-up	L-1	A / B / C / H	PT1621

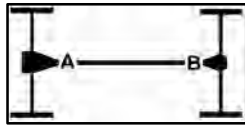

APPLICATION A-1

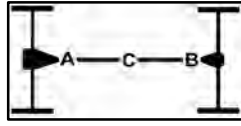

APPLICATION B-1

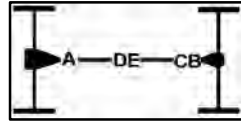

APPLICATION C-1

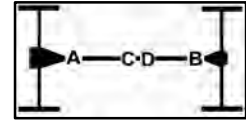

APPLICATION D-1

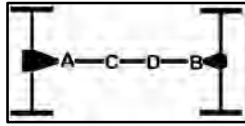

APPLICATION E-1

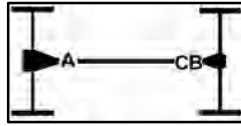

APPLICATION F-1

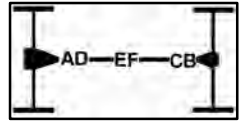

APPLICATION H-1

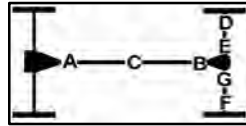

APPLICATION I-1

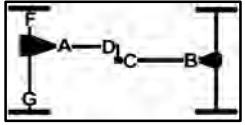

APPLICATION K-1

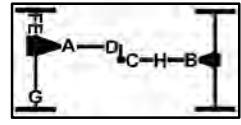

APPLICATION L-1

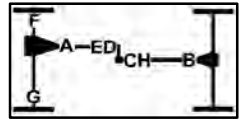

APPLICATION N-1



APPLICATION O-1

MAKE/YEARS FITMENT U-JOINT DESCRIPTION LOCATION POSITION PART NO.

ISUZU

ISUZU

RODEO 2WD					
91-04 All Models - 2 or 3 Joint Drive Shaft	4 OSR > 1.063" Brg O.D/ 3.217" Stack-up	B-1	A / B / C	PT521HD	
RODEO 4WD					
91-04 All Models	4 OSR > 1.063" Brg O.D/ 3.217" Stack-up	L-1	A / B / C / D / H	PT521HD	
TROOPER 2WD					
00-02 All Models	4 ISR > 1.142" Brg O.D./2.835" Stack-up	B-1	A / B / C	PT411	
TROOPER 4WD					
98-02 All Models	4 ISR > 1.142" Brg O.D./2.089" Stack-up	L-1	A / D	PT1621	
	4 ISR > 1.142" Brg O.D./2.835" Stack-up	L-1	B / C	PT411	
87-97 All Models	4 ISR > 1.142" Brg O.D./2.089" Stack-up	L-1	A / B / C / D / H	PT1621	
84-86 All Models	4 OSR > .938" Brg O.D./2.407" Stack-up	L-1	A / B / C / H	PT514	
	4 ISR > 1.142" Brg O.D./2.089" Stack-up	L-1	D	PT1621	

JAGUAR

JAGUAR

XJ-12					
73-79 All Models - 2 or 3 Joint Drive Shaft	4 OSR > 1.063" Brg O.D/ 3.217" Stack-up	B-1	A / B / C	PT521HD	
XJ-6					
70-85 All Models - 2 or 3 Joint Drive Shaft	4 OSR > 1.063" Brg O.D/ 3.217" Stack-up	B-1	A / B / C	PT521HD	
XJ-S					
76-85 All Models - 2 or 3 Joint Drive Shaft	4 OSR > 1.063" Brg O.D/ 3.217" Stack-up	B-1	A / B / C	PT521HD	
XKE					
70-74 All Models - 2 or 3 Joint Drive Shaft	4 OSR > 1.063" Brg O.D/ 3.217" Stack-up	B-1	A / B / C	PT521HD	

JEEP

JEEP

CHEROKEE 2WD					
85-01 All Models	4 OSR > 1.063" Brg O.D/ 3.217" Stack-up	A-1	A / B	PT521HD	
	4 OSR > 1.063" Brg O.D/ 3.217" Stack-up	A-1	A / B	PT521HD	
74-84 All Models	4 OSR > 1.078" Brg O.D./2.121" Stack-up	A-1	A / B	PT266	

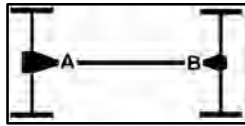

APPLICATION A-1

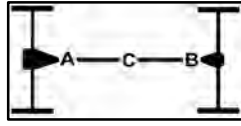

APPLICATION B-1

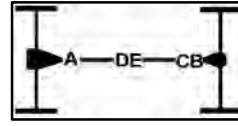

APPLICATION C-1

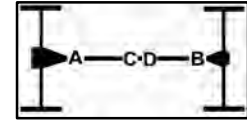

APPLICATION D-1

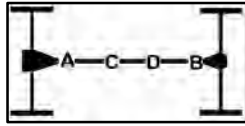

APPLICATION E-1

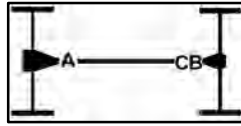

APPLICATION F-1

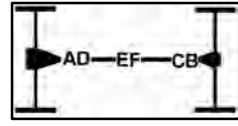

APPLICATION H-1

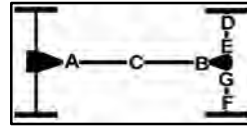

APPLICATION I-1

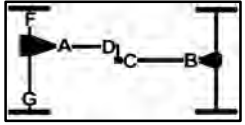

APPLICATION K-1

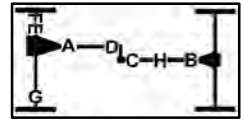

APPLICATION L-1

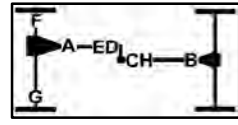

APPLICATION N-1

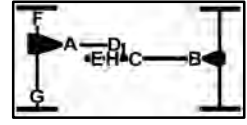

APPLICATION O-1

MAKE/YEARS FITMENT U-JOINT DESCRIPTION LOCATION POSITION PART NO.

JEEP

JEEP

MAKE/YEARS	FITMENT	U-JOINT DESCRIPTION	LOCATION	POSITION	PART NO.
CHEROKEE 4WD					
99-01	All Models	4 OSR > 1.063" Brg O.D/ 3.217" Stack-up	N-1	A / B / C / D / E	PT521HD
		4 OSR > 1.063" Brg O.D/ 3.622" Stack-up	N-1	C	PT530
		4 ISR > 1.188" Brg O.D./2.187" Stack-up	N-1	F / G	PT297
93-98	All Models	4 OSR > 1.063" Brg O.D/ 3.217" Stack-up	N-1	A / B / C / D / E	PT521HD
		4 ISR > 1.063" Brg O.D/2.183" Stack-up	N-1	F / G	PT260
		4 ISR > 1.188" Brg O.D./2.187" Stack-up	N-1	F / G	PT297
84-92	All Models	4 OSR > 1.063" Brg O.D/ 3.217" Stack-up	N-1	A / B / C / D / E	PT521HD
		4 ISR > 1.063" Brg O.D/2.183" Stack-up	N-1	F / G	PT260
74-83	All Models	4 OSR > 1.063" Brg O.D/ 3.217" Stack-up	N-1	A / B / C / D / E	PT521HD
		4 ISR > 1.078" Brg O.D./2.121" Stack-up	N-1	B	PT266
		4 ISR > 1.188" Brg O.D./2.187" Stack-up	N-1	F / G	PT297
70-73	All Models	2 ISR & 2 OSR > 1.063"/1.000" Brg O.D/ 1.740" ISR/2.437 OSR Stack-Up	L-1	A / B / C / D	PT248
		4 OSR > 1.063" Brg O.D/ 3.217" Stack-up	L-1	A / B / C / D	PT521HD
		4 ISR > 1.063" Brg O.D/2.183" Stack-up	L-1	F / G	PT260
CJ5 4WD					
74-83	All Models	4 OSR > 1.063" Brg O.D/ 3.217" Stack-up	N-1	A / B / C / D / E	PT521HD
		4 ISR > 1.063" Brg O.D/2.183" Stack-up	N-1	F / G	PT260
70-73	All Models	2 ISR & 2 OSR > 1.063"/1.000" Brg O.D/ 1.740" ISR/2.437 OSR Stack-Up	L-1	A / D	PT248
		4 OSR > 1.063" Brg O.D/ 3.217" Stack-up	L-1	B / C	PT521HD
		4 ISR > 1.063" Brg O.D/2.183" Stack-up	L-1	F / G	PT260
CJ6 4WD					
74-75	All Models	4 OSR > 1.063" Brg O.D/ 3.217" Stack-up	N-1	A / B / C / D / E	PT521HD
		4 ISR > 1.063" Brg O.D/2.183" Stack-up	N-1	F / G	PT260
70-73	All Models	2 ISR & 2 OSR > 1.063"/1.000" Brg O.D/ 1.740" ISR/2.437 OSR Stack-Up	L-1	A / D	PT248
		4 OSR > 1.063" Brg O.D/ 3.217" Stack-up	L-1	B / C	PT521HD
		4 ISR > 1.063" Brg O.D/2.183" Stack-up	L-1	F / G	PT260
CJ7 4WD					
76-86	All Models	4 OSR > 1.063" Brg O.D/ 3.217" Stack-up	N-1	A / B / C / D / E	PT521HD
		4 ISR > 1.063" Brg O.D/2.183" Stack-up	N-1	F / G	PT260

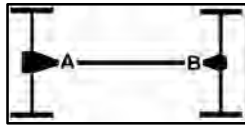

APPLICATION A-1

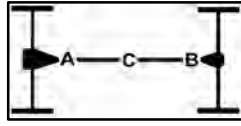

APPLICATION B-1

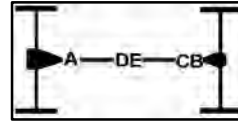

APPLICATION C-1

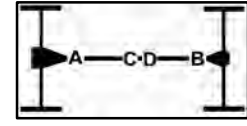

APPLICATION D-1

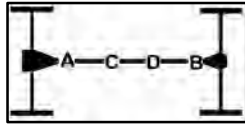

APPLICATION E-1

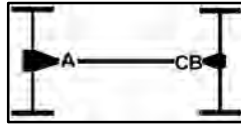

APPLICATION F-1

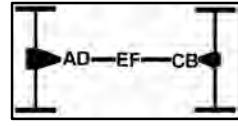

APPLICATION H-1

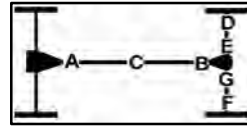

APPLICATION I-1

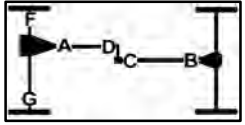

APPLICATION K-1

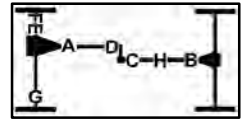

APPLICATION L-1

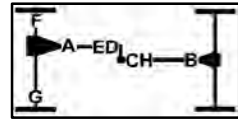

APPLICATION N-1

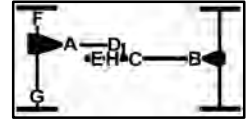

APPLICATION O-1

MAKE/YEARS FITMENT U-JOINT DESCRIPTION LOCATION POSITION PART NO.

JEEP

JEEP

MAKE/YEARS	FITMENT	U-JOINT DESCRIPTION	LOCATION	POSITION	PART NO.
CJ8 (SCRAMBLER) 2WD					
1985	All Models	4 OSR > 1.063" Brg O.D/ 3.217" Stack-up	A-1	A / B	PT521HD
81-84	All Models	4 OSR > 1.063" Brg O.D/ 3.217" Stack-up	A-1	A / B	PT521HD
		4 ISR > 1.078" Brg O.D./2.121" Stack-up	A-1	A / B	PT266
CJ8 (SCRAMBLER) 4WD					
81-85	All Models	4 OSR > 1.063" Brg O.D/ 3.217" Stack-up	N-1	A / B / C / D / E	PT521HD
		4 ISR > 1.063" Brg O.D/2.183" Stack-up	N-1	F / G	PT260
COMANCHE 2WD					
86-92	All Models	4 OSR > 1.063" Brg O.D/ 3.217" Stack-up	A-1	A / B	PT521HD
COMANCHE 4WD					
86-92	All Models	4 OSR > 1.063" Brg O.D/ 3.217" Stack-up	N-1	A / B / C / D / E	PT521HD
		4 ISR > 1.063" Brg O.D/2.183" Stack-up	N-1	F / G	PT260
DJ5 2WD					
70-73	All Models	4 OSR > 1.063" Brg O.D/ 3.217" Stack-up	A-1	A / B	PT521HD
GRAND CHEROKEE 2WD					
02-07	All Models	4 OSR > 1.063" Brg O.D/ 3.217" Stack-up	A-1	A / B	PT521HD
00-01	All Models - 4.0L 6 Cyl.	4 OSR > 1.063" Brg O.D/ 3.217" Stack-up	A-1	A / B	PT521HD
	All Models - 4.7L V8	4 OSR > 1.063" Brg O.D/ 3.622" Stack-up	A-1	A	PT530
		4 OSR > 1.063" Brg O.D/ 3.217" Stack-up	A-1	B	PT521HD
93-99	All Models	4 OSR > 1.063" Brg O.D/ 3.217" Stack-up	A-1	A / B	PT521HD
GRAND CHEROKEE 4WD					
02-04	All Models	4 OSR > 1.063" Brg O.D/ 3.217" Stack-up	N-1	A / B / C / D / E	PT521HD
		4 OSR > 1.063" Brg O.D/ 3.622" Stack-up	N-1	C	PT530
99-01	All Models	4 OSR > 1.063" Brg O.D/ 3.217" Stack-up	N-1	A / B / C / D / E	PT521HD
		4 ISR > 1.188" Brg O.D./2.187" Stack-up	N-1	F / G	PT297
1998	All Models	4 OSR > 1.063" Brg O.D/ 3.217" Stack-up	N-1	A / B / C / D / E	PT521HD
		4 OSR > 1.063" Brg O.D/ 3.622" Stack-up	N-1	B / C	PT530
		4 ISR > 1.188" Brg O.D./2.187" Stack-up	N-1	F / G	PT297

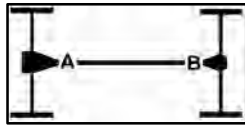

APPLICATION A-1

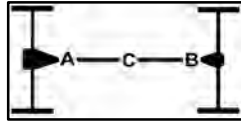

APPLICATION B-1

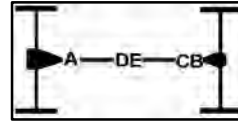

APPLICATION C-1

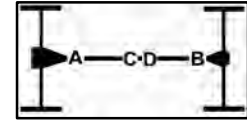

APPLICATION D-1

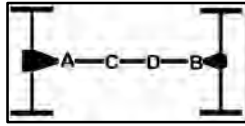

APPLICATION E-1

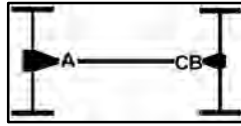

APPLICATION F-1

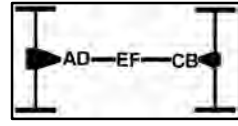

APPLICATION H-1

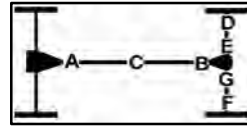

APPLICATION I-1

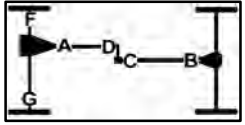

APPLICATION K-1

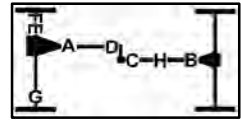

APPLICATION L-1

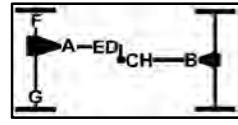

APPLICATION N-1

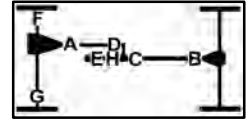

APPLICATION O-1

MAKE/YEARS FITMENT U-JOINT DESCRIPTION LOCATION POSITION PART NO.

JEEP

JEEP

MAKE/YEARS	FITMENT	U-JOINT DESCRIPTION	LOCATION	POSITION	PART NO.
GRAND CHEROKEE 4WD					
93-97	All Models	4 OSR > 1.063" Brg O.D/ 3.217" Stack-up	N-1	A / B / C / D / E	PT521HD
		4 ISR > 1.188" Brg O.D./2.187" Stack-up	N-1	F / G	PT297
GRAND WAGONEER 2WD					
1993	All Models	4 OSR > 1.063" Brg O.D/ 3.217" Stack-up	A-1	A / B	PT521HD
85-91	All Models	4 OSR > 1.063" Brg O.D/ 3.217" Stack-up	A-1	A / B	PT521HD
1984	All Models	4 OSR > 1.063" Brg O.D/ 3.217" Stack-up	A-1	A / B	PT521HD
		4 ISR > 1.078" Brg O.D./2.121" Stack-up	A-1	A / B	PT266
GRAND WAGONEER 4WD					
1993	All Models	4 OSR > 1.063" Brg O.D/ 3.217" Stack-up	N-1	A / B / C / D / E	PT521HD
		4 ISR > 1.188" Brg O.D./2.187" Stack-up	N-1	F / G	PT297
84-91	All Models	4 OSR > 1.063" Brg O.D/ 3.217" Stack-up	N-1	A / B / C / D / E	PT521HD
		4 ISR > 1.188" Brg O.D./2.187" Stack-up	N-1	F / G	PT297
J SERIES TRUCK 2WD					
85-88	All Models	4 OSR > 1.063" Brg O.D/ 3.217" Stack-up	A-1	A / B	PT521HD
70-84	All Models	4 OSR > 1.063" Brg O.D/ 3.217" Stack-up	A-1	A / B	PT521HD
		4 ISR > 1.078" Brg O.D./2.121" Stack-up	A-1	A / B	PT266
J SERIES TRUCK4WD					
74-88	All Models	4 OSR > 1.063" Brg O.D/ 3.217" Stack-up	N-1	A / B / C / D / E	PT521HD
		4 ISR > 1.188" Brg O.D./2.187" Stack-up	N-1	F / G	PT297
70-73	All Models	4 OSR > 1.063" Brg O.D/ 3.217" Stack-up	N-1	A / B / C / D / E	PT521HD
		4 ISR > 1.063" Brg O.D/2.183" Stack-up	N-1	F / G	PT260
LIBERTY 2WD					
04-07	All Models	4 OSR > 1.063" Brg O.D/ 3.217" Stack-up	A-1	A / B	PT521HD
02-03	All Models	4 OSR > 1.063" Brg O.D/ 3.622" Stack-up	A-1	A / B	PT530
		4 OSR > 1.063" Brg O.D/ 3.217" Stack-up	A-1	A / B	PT521HD
LIBERTY 4WD					
02-07	All Models	4 OSR > 1.063" Brg O.D/ 3.217" Stack-up	L-1	B / C	PT521HD
		4 OSR > 1.063" Brg O.D/ 3.622" Stack-up	L-1	B / C	PT530

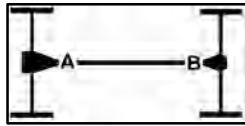

APPLICATION A-1

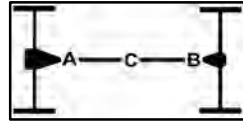

APPLICATION B-1

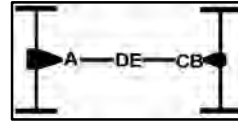

APPLICATION C-1

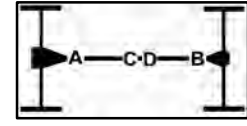

APPLICATION D-1

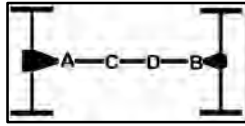

APPLICATION E-1

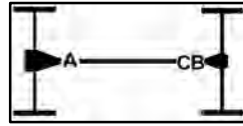

APPLICATION F-1

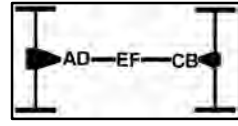

APPLICATION H-1

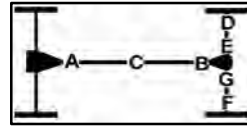

APPLICATION I-1

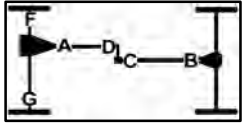

APPLICATION K-1

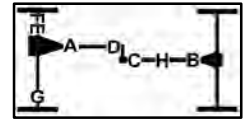

APPLICATION L-1

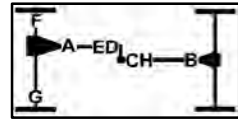

APPLICATION N-1

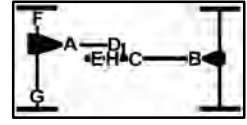

APPLICATION O-1

MAKE/YEARS FITMENT U-JOINT DESCRIPTION LOCATION POSITION PART NO.

JEEP

JEEP

WAGONEER 2WD					
85-93	All Models	4 OSR > 1.063" Brg O.D/ 3.217" Stack-up	A-1	A / B	PT521HD
70-84	All Models	4 OSR > 1.063" Brg O.D/ 3.217" Stack-up	A-1	A / B	PT521HD
		4 ISR > 1.078" Brg O.D./2.121" Stack-up	A-1	A / B	PT266
WAGONEER 4WD					
84-93	All Models	4 OSR > 1.063" Brg O.D/ 3.217" Stack-up	N-1	A / B / C / D / E	PT521HD
		4 ISR > 1.063" Brg O.D/2.183" Stack-up	N-1	F / G	PT260
74-83	All Models	4 OSR > 1.063" Brg O.D/ 3.217" Stack-up	N-1	A / B / C / D / E	PT521HD
		4 ISR > 1.078" Brg O.D./2.121" Stack-up	N-1	B	PT266
		4 ISR > 1.188" Brg O.D./2.187" Stack-up	N-1	F / G	PT297
70-73	All Models	2 ISR & 2 OSR > 1.063"/1.000" Brg O.D/ 1.740" ISR/2.437" OSR Stack-Up	L-1	A / B / C / D	PT248
		4 OSR > 1.063" Brg O.D/ 3.217" Stack-up	L-1	A / B / C / D	PT521HD
		4 ISR > 1.063" Brg O.D./2.183" Stack-up	L-1	F / G	PT260
WRANGLER 2WD					
87-95	All Models	4 OSR > 1.063" Brg O.D/ 3.217" Stack-up	A-1	A / B	PT521HD
WRANGLER 4WD					
97-07	All Models	4 OSR > 1.063" Brg O.D/ 3.217" Stack-up	N-1	A / B / C / D / E	PT521HD
		4 ISR > 1.188" Brg O.D./2.187" Stack-up	N-1	F / G	PT297
87-95	All Models	4 OSR > 1.063" Brg O.D/ 3.217" Stack-up	L-1	A / B / C / D	PT521HD
		4 ISR > 1.063" Brg O.D./2.183" Stack-up	L-1	F / G	PT260

KIA

KIA

SPORTAGE 2WD					
95-02	All Models	4 ISR > 1.044" Brg O.D./1.986" Stack-up	B-1	A / B / C	PT1622
SPORTAGE 4WD					
95-02	All Models	4 ISR > 1.044" Brg O.D./1.986" Stack-up	L-1	A / B / C / D	PT1622

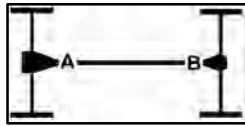

APPLICATION A-1

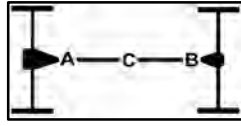

APPLICATION B-1

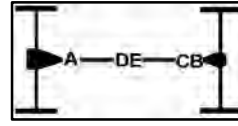

APPLICATION C-1

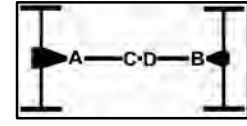

APPLICATION D-1

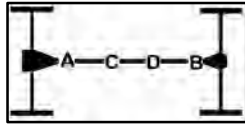

APPLICATION E-1

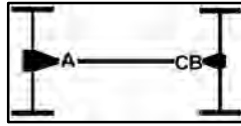

APPLICATION F-1

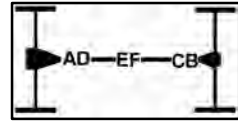

APPLICATION H-1

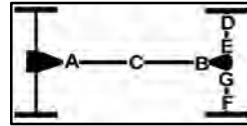

APPLICATION I-1

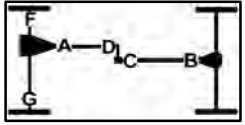

APPLICATION K-1

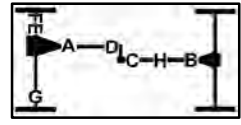

APPLICATION L-1

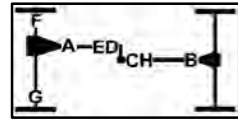

APPLICATION N-1

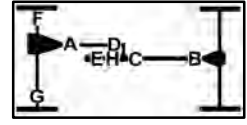

APPLICATION O-1

MAKE/YEARS FITMENT U-JOINT DESCRIPTION LOCATION POSITION PART NO.

LANDROVER

LANDROVER

DEFENDER 90						
1997	All Models	4 OSR > 1.063" Brg O.D./2.931 Stack-up	L-1	A / B / C / D	PT504	
94-95	All Models	4 OSR > 1.063" Brg O.D./2.931 Stack-up	L-1	A / B / C / D	PT504	
DEFENDER 110						
1993	All Models	4 OSR > 1.063" Brg O.D./2.931 Stack-up	L-1	A / B / C / D	PT504	
DISCOVERY						
94-04	All Models	4 OSR > 1.063" Brg O.D./2.931 Stack-up	L-1	A / B / C / D	PT504	
RANGE ROVER						
87-02	All Models	4 OSR > 1.063" Brg O.D./2.931 Stack-up	L-1	A / B / C / D	PT504	

LEXUS

LEXUS

GX470 4WD						
03-06	All Models	4 ISR > 1.142" Brg O.D./2.049" Stack-up	K-1	A / B / C / D	PT1619	
LX450 4WD						
96-97	All Models	4 ISR > 1.142" Brg O.D./2.049" Stack-up	K-1	A / B / C / D	PT1619	
LX470 4WD						
98-06	All Models	4 ISR > 1.142" Brg O.D./2.049" Stack-up	K-1	A / B / C / D	PT1619	

LINCOLN

LINCOLN

AVIATOR 2WD						
03-05	All Models	4 OSR > 1.063" Brg O.D./ 3.622" Stack-up	A-1	A / B	PT530	
AVIATOR 4WD						
03-05	All Models	4 OSR > 1.063" Brg O.D./ 3.622" Stack-up	L-1	B / C	PT530	
BLACKWOOD 2WD						
2002	All Models	4 OSR > 1.188" Brg O.D./3.622" Stack-up	A-1	A / B	PT578	
BLACKWOOD 4WD						
2002	All Models	4 OSR > 1.063" Brg O.D./ 3.622" Stack-up	L-1	A / B	PT530	
		4 OSR > 1.188" Brg O.D./3.622" Stack-up	L-1	A / B	PT578	

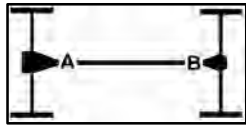

APPLICATION A-1

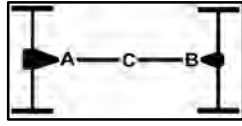

APPLICATION B-1

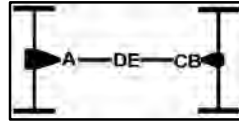

APPLICATION C-1

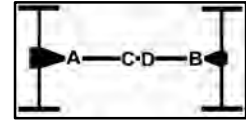

APPLICATION D-1

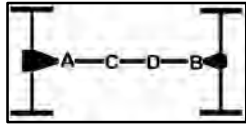

APPLICATION E-1

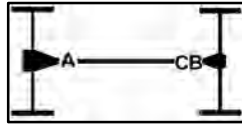

APPLICATION F-1

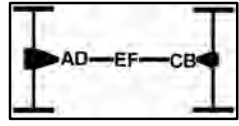

APPLICATION H-1

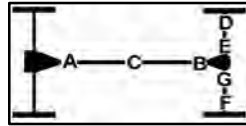

APPLICATION I-1

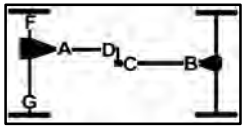

APPLICATION K-1

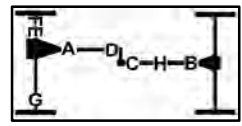

APPLICATION L-1

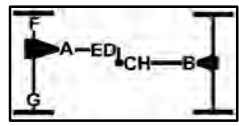

APPLICATION N-1



APPLICATION O-1

MAKE/YEARS FITMENT U-JOINT DESCRIPTION LOCATION POSITION PART NO.

LINCOLN

LINCOLN

MAKE/YEARS	FITMENT	U-JOINT DESCRIPTION	LOCATION	POSITION	PART NO.
CONTINENTAL					
82-87	All Models	4 OSR > 1.063" Brg O.D/ 3.217" Stack-up	F-1	A / B / C	PT521HD
80-81	All Models - Towing Option	4 OSR > 1.063" Brg O.D/ 3.622" Stack-up	A-1	A / B	PT530
	All Models - Exc. Towing Option	4 OSR > 1.063" Brg O.D/ 3.217" Stack-up	A-1	A / B	PT521HD
78-79	All Models - 2 Kits At Each Location	4 ISR > 1.125" Brg O.D./2.555 Stack-up	A-1	A / B	PT3105
70-77	All Models - 2 Kits At Each Location	4 OSR > 1.063" Brg O.D/ 3.622" Stack-up	A-1	A / B	PT530
MARK III					
70-71	All Models - 2 Kits At Each Location	4 OSR > 1.063" Brg O.D/ 3.622" Stack-up	A-1	A	PT530
MARK IV					
73-76	All Models	4 OSR > 1.063" Brg O.D/ 3.622" Stack-up	A-1	A	PT530
1972	All Models	4 OSR > 1.063" Brg O.D/ 3.622" Stack-up	A-1	A	PT530
		2 ISR & 2 OSR > 1.063"/1.125" Brg O.D/ 2.767" ISR	A-1	B	PT1204
MARK V					
77-79	All Models	4 OSR > 1.063" Brg O.D/ 3.622" Stack-up	A-1	A / B	PT530
		2 ISR & 2 OSR > 1.063"/1.125" Brg O.D/ 2.767" ISR	A-1	B	PT1204
MARK VI					
80-83	All Models - Towing Option	4 OSR > 1.063" Brg O.D/ 3.622" Stack-up	A-1	A / B	PT530
	All Models - Exc. Towing Option	4 OSR > 1.063" Brg O.D/ 3.217" Stack-up	A-1	A / B	PT521HD
MARK VII					
84-92	All Models	4 OSR > 1.063" Brg O.D/ 3.217" Stack-up	F-1	A / B / C	PT521HD
MARK VIII					
93-98	All Models	4 OSR > 1.063" Brg O.D/ 3.622" Stack-up	A-1	A / B	PT530
NAVIGATOR 2WD					
05-06	All Models	4 OSR > 1.063" Brg O.D/ 3.622" Stack-up	A-1	A / B	PT530
98-04	All Models	4 OSR > 1.188" Brg O.D./3.622" Stack-up	A-1	A / B	PT578

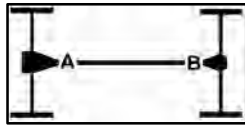

APPLICATION A-1

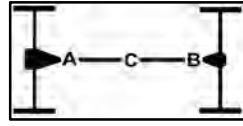

APPLICATION B-1

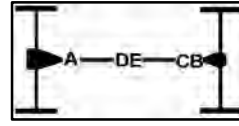

APPLICATION C-1

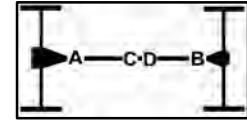

APPLICATION D-1

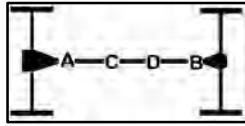

APPLICATION E-1

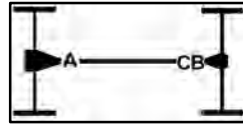

APPLICATION F-1

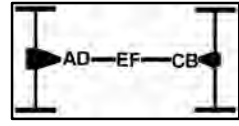

APPLICATION H-1

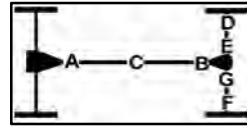

APPLICATION I-1

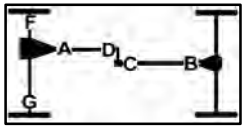

APPLICATION K-1

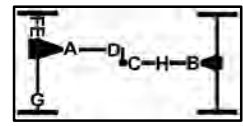

APPLICATION L-1

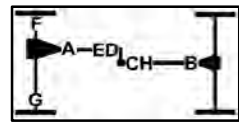

APPLICATION N-1



APPLICATION O-1

MAKE/YEARS FITMENT U-JOINT DESCRIPTION LOCATION POSITION PART NO.

LINCOLN

LINCOLN

NAVIGATOR 4WD					
98-06 All Models	4 OSR > 1.063" Brg O.D/ 3.622" Stack-up		L-1	A / D	PT530
	4 OSR > 1.188" Brg O.D./3.622" Stack-up		L-1	B / C	PT578
TOWN CAR					
95-07 All Models	4 OSR > 1.063" Brg O.D/ 3.622" Stack-up		A-1	A / B	PT530
	82-94 All Models - Towing Option	4 OSR > 1.063" Brg O.D/ 3.622" Stack-up	A-1	A / B	PT530
	All Models - Exc. Towing Option	4 OSR > 1.063" Brg O.D/ 3.217" Stack-up	A-1	A / B	PT521HD
VERSAILLES					
79-80 All Models	4 OSR > 1.063" Brg O.D/ 3.217" Stack-up		F-1	A / B / C	PT521HD
	77-78 All Models	4 OSR > 1.063" Brg O.D/ 3.622" Stack-up	F-1	A / B / C	PT530

MAZDA

MAZDA

1200					
71-73 All Models	4 ISR > .985" Brg O.D/ 1.717" Stack-up		A-1	A / B	PT1606
	616				
71-72 All Models	4 ISR > .985" Brg O.D/ 1.717" Stack-up		A-1	A / B	PT1606
	618				
71-72 All Models	4 ISR > .985" Brg O.D/ 1.717" Stack-up		A-1	A / B	PT1606
	626				
80-82 All Models	4 ISR > .985" Brg O.D/ 1.717" Stack-up		A-1	A / B	PT1606
	808				
72-77 All Models	4 ISR > .985" Brg O.D/ 1.717" Stack-up		A-1	A / B	PT1606
	B1600 2WD				
72-76 All Models - 2 or 3 Joint Driveshaft	4 ISR > 1.102" Brg O.D./2.323" Stack-up		B-1	A / B / C	PT1610
	B1800 2WD				
77-78 All Models - 2 or 3 Joint Driveshaft	4 ISR > 1.102" Brg O.D./2.323" Stack-up		B-1	A / B / C	PT1610

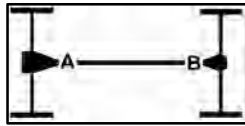

APPLICATION A-1

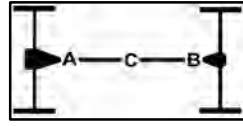

APPLICATION B-1

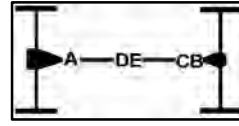

APPLICATION C-1

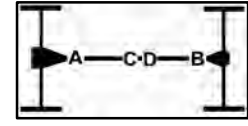

APPLICATION D-1

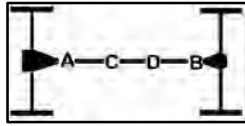

APPLICATION E-1

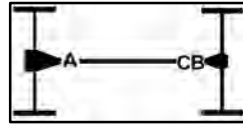

APPLICATION F-1

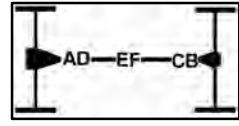

APPLICATION H-1

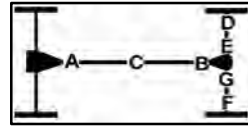

APPLICATION I-1

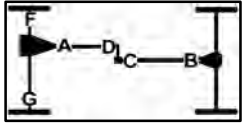

APPLICATION K-1

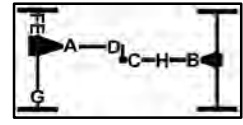

APPLICATION L-1

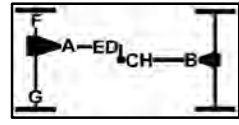

APPLICATION N-1



APPLICATION O-1

MAKE/YEARS FITMENT U-JOINT DESCRIPTION LOCATION POSITION PART NO.

MAZDA

MAZDA

MAKE/YEARS	FITMENT	U-JOINT DESCRIPTION	LOCATION	POSITION	PART NO.
B2000 2WD					
86-88	All Models	2 or 3 Joint Driveshaft 4 ISR > 1.102" Brg O.D./2.323" Stack-up	B-1	C	PT1610
79-84	All Models	2 or 3 Joint Driveshaft 4 ISR > 1.102" Brg O.D./2.323" Stack-up	B-1	A / B / C	PT1610
B2000 4WD					
86-88	All Models	2 or 3 Joint Driveshaft 4 ISR > 1.102" Brg O.D./2.323" Stack-up	B-1	A / B / C	PT1610
B2200 2WD					
87-93	All Models	2 or 3 Joint Driveshaft 4 ISR > 1.102" Brg O.D./2.323" Stack-up	B-1	C	PT1610
82-84	All Models	2 or 3 Joint Driveshaft 4 ISR > 1.102" Brg O.D./2.323" Stack-up	B-1	A / B / C	PT1610
B2200 4WD					
87-93	All Models	2 or 3 Joint Driveshaft 4 ISR > 1.102" Brg O.D./2.323" Stack-up	B-1	C	PT1610
B2300 2WD					
01-07	All Models	4 OSR > 1.063" Brg O.D/ 3.622" Stack-up	A-1	A / B	PT530
		2 ISR & 2 OSR > 1.063"/1.125" Brg O.D/ 2.767" ISR	A-1	A / B	PT1204
94-97	All Models	4 OSR > 1.063" Brg O.D/ 3.217" Stack-up	B-1	A / B / C	PT521HD
B2300 4WD					
01-06	All Models	4 OSR > 1.063" Brg O.D/ 3.217" Stack-up	N-1	A / D	PT521HD
		4 OSR > 1.063" Brg O.D/ 3.622" Stack-up	N-1	B / C	PT530
94-97	All Models	4 OSR > 1.063" Brg O.D/ 3.217" Stack-up	N-1	A / D / E	PT521HD
	All Models - 108" & 125" Wheel Base	4 OSR > 1.063" Brg O.D/ 3.217" Stack-up	N-1	B / C / H	PT521HD
	All Models - 114" Wheel Base	4 OSR > 1.063" Brg O.D/ 3.622" Stack-up	N-1	B / C	PT530
	All Models	4 ISR > 1.188" Brg O.D./2.187" Stack-up	L-1	E / F / G	PT297
B2400 2WD					
98-01	All Models	4 OSR > 1.063" Brg O.D/ 3.622" Stack-up	A-1	A / B	PT530
		2 ISR & 2 OSR > 1.063"/1.125" Brg O.D/ 2.767" ISR	A-1	A / B	PT1204
B2400 4WD					
98-01	All Models	4 OSR > 1.063" Brg O.D/ 3.217" Stack-up	N-1	A / D	PT521HD
		4 OSR > 1.063" Brg O.D/ 3.622" Stack-up	N-1	B / C	PT530

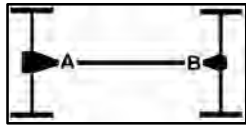

APPLICATION A-1

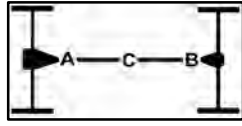

APPLICATION B-1

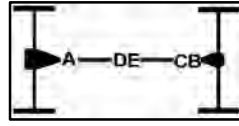

APPLICATION C-1

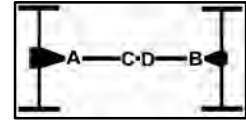

APPLICATION D-1

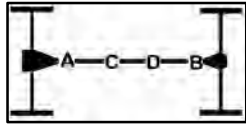

APPLICATION E-1

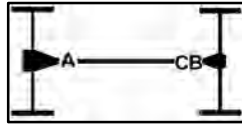

APPLICATION F-1

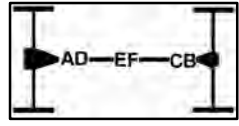

APPLICATION H-1

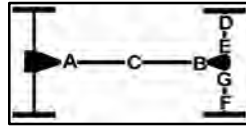

APPLICATION I-1

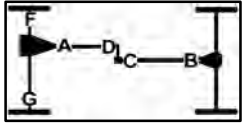

APPLICATION K-1

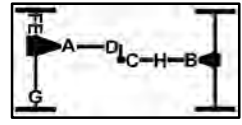

APPLICATION L-1

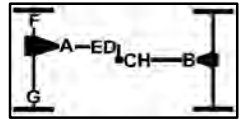

APPLICATION N-1



APPLICATION O-1

MAKE/YEARS FITMENT U-JOINT DESCRIPTION LOCATION POSITION PART NO.

MAZDA

MAZDA

MAKE/YEARS	FITMENT	U-JOINT DESCRIPTION	LOCATION	POSITION	PART NO.
B2600 2WD					
87-93	All Models	2 or 3 Joint Driveshaft 4 ISR > 1.102" Brg O.D./2.323" Stack-up	B-1	C	PT1610
B2600 4WD					
87-93	All Models	2 or 3 Joint Driveshaft 4 ISR > 1.102" Brg O.D./2.323" Stack-up	B-1	C	PT1610
B3000 2WD					
98-06	All Models	4 OSR > 1.063" Brg O.D/ 3.622" Stack-up	A-1	A / B	PT530
		2 ISR & 2 OSR > 1.063"/1.125" Brg O.D/ 2.767" ISR	A-1	A / B	PT1204
94-96	All Models	4 OSR > 1.063" Brg O.D/ 3.217" Stack-up	B-1	A / B / C	PT521HD
B3000 4WD					
98-06	All Models	4 OSR > 1.063" Brg O.D/ 3.217" Stack-up	N-1	A / D	PT521HD
		4 OSR > 1.063" Brg O.D/ 3.622" Stack-up	N-1	B / C	PT530
94-96	All Models	4 OSR > 1.063" Brg O.D/ 3.217" Stack-up	N-1	A / D / E	PT521HD
	All Models - 108" & 125" Wheel Base	4 OSR > 1.063" Brg O.D/ 3.217" Stack-up	N-1	B / C / H	PT521HD
	All Models - 114" Wheel Base	4 OSR > 1.063" Brg O.D/ 3.622" Stack-up	N-1	B / C	PT530
	All Models	4 ISR > 1.188" Brg O.D./2.187" Stack-up	L-1	E / F / G	PT297
B4000 2WD					
98-06	All Models	4 OSR > 1.063" Brg O.D/ 3.622" Stack-up	A-1	A / B	PT530
		2 ISR & 2 OSR > 1.063"/1.125" Brg O.D/ 2.767" ISR	A-1	A / B	PT1204
94-97	All Models	4 OSR > 1.063" Brg O.D/ 3.217" Stack-up	B-1	A / B / C	PT521HD
B4000 4WD					
98-06	All Models	4 OSR > 1.063" Brg O.D/ 3.217" Stack-up	N-1	A / D	PT521HD
		4 OSR > 1.063" Brg O.D/ 3.622" Stack-up	N-1	B / C	PT530
94-97	All Models	4 OSR > 1.063" Brg O.D/ 3.217" Stack-up	N-1	A / D / E	PT521HD
	All Models - 108" & 125" Wheel Base	4 OSR > 1.063" Brg O.D/ 3.217" Stack-up	N-1	B / C / H	PT521HD
	All Models - 114" Wheel Base	4 OSR > 1.063" Brg O.D/ 3.622" Stack-up	N-1	B / C	PT530
	All Models	4 ISR > 1.188" Brg O.D./2.187" Stack-up	L-1	E / F / G	PT297

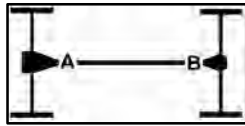

APPLICATION A-1

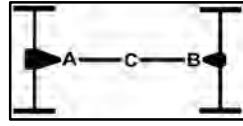

APPLICATION B-1

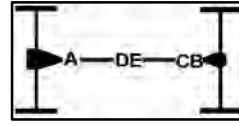

APPLICATION C-1

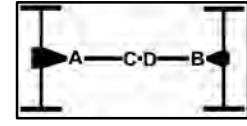

APPLICATION D-1

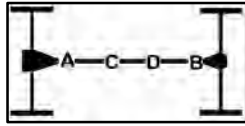

APPLICATION E-1

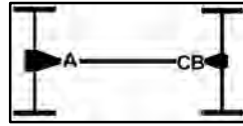

APPLICATION F-1

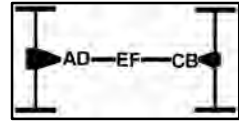

APPLICATION H-1

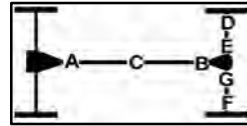

APPLICATION I-1

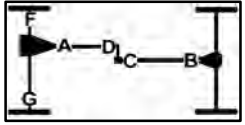

APPLICATION K-1

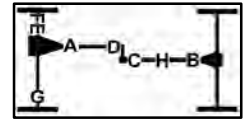

APPLICATION L-1

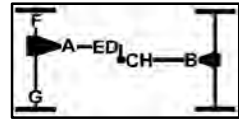

APPLICATION N-1

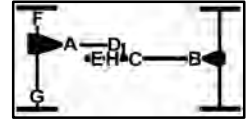

APPLICATION O-1

MAKE/YEARS FITMENT U-JOINT DESCRIPTION LOCATION POSITION PART NO.

MAZDA

MAZDA

MAKE/YEARS	FITMENT	U-JOINT DESCRIPTION	LOCATION	POSITION	PART NO.
COSMO					
76-78	All Models	4 ISR > 1.044" Brg O.D/ 1.986" Stack-up	A-1	A / B	PT1622
GLC					
77-85	All Models	4 ISR > .891" Brg O.D/ 1.484" Stack-up	A-1	A / B	PT1623
MIZER					
76-77	All Models	4 ISR > .985" Brg O.D/ 1.717" Stack-up	A-1	A / B	PT1606
MPV 4WD					
89-95	All Models	4 ISR > 1.102" Brg O.D./2.323" Stack-up	L-1	B / C	PT1610
NAVAJO 2WD					
91-94	All Models	4 OSR > 1.063" Brg O.D/ 3.217" Stack-up	A-1	A / B	PT521HD
NAVAJO 4WD					
91-94	All Models	4 OSR > 1.063" Brg O.D/ 3.217" Stack-up	N-1	A / B / C / D / E	PT521HD
		4 ISR > 1.188" Brg O.D./2.187" Stack-up	L-1	E / F / G	PT297
		4 ISR & 4 OSR > 1.063" Brg O.D/1.635"ISR - 2.437 OSR Stack-up	L-1	E / F / G	PT456
R100					
71-72	All Models	4 ISR > .985" Brg O.D/ 1.717" Stack-up	A-1	A / B	PT1606
ROTARY PICKUP					
74-77	All Models - 2 or 3 Joint Driveshaft	4 ISR > 1.102" Brg O.D./2.323" Stack-up	B-1	A / B / C	PT1610
RX-2					
71-74	All Models	4 ISR > .985" Brg O.D/ 1.717" Stack-up	A-1	A / B	PT1606
RX-3					
72-78	All Models	4 ISR > .985" Brg O.D/ 1.717" Stack-up	A-1	A / B	PT1606
RX-4					
74-78	All Models	4 ISR > 1.044" Brg O.D/ 1.986" Stack-up	B-1	A / B / C	PT1622
RX-7					
79-83	All Models	4 ISR > .985" Brg O.D/ 1.717" Stack-up	A-1	A / B	PT1606
TRIBUTE 4WD					
01-06	All Models	4 OSR > 1.063" Brg O.D/ 3.217" Stack-up	I-1	A / C	PT521HD

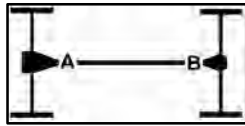

APPLICATION A-1

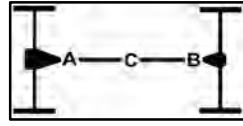

APPLICATION B-1

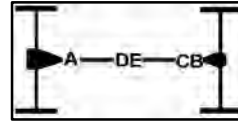

APPLICATION C-1

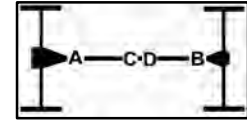

APPLICATION D-1

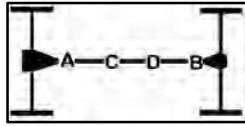

APPLICATION E-1

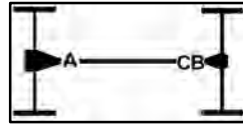

APPLICATION F-1

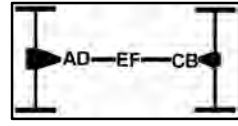

APPLICATION H-1

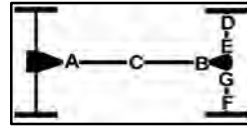

APPLICATION I-1

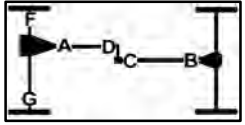

APPLICATION K-1

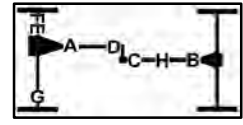

APPLICATION L-1

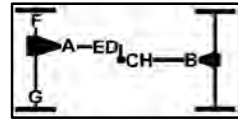

APPLICATION N-1

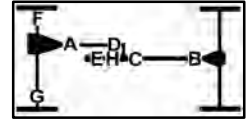

APPLICATION O-1

MAKE/YEARS FITMENT U-JOINT DESCRIPTION LOCATION POSITION PART NO.

MERCURY

MERCURY

MAKE/YEARS	FITMENT	U-JOINT DESCRIPTION	LOCATION	POSITION	PART NO.
BOBCAT					
1980	All Models	4 OSR > 1.063" Brg O.D/ 3.217" Stack-up	A-1	A / B	PT521HD
75-79	All Models	4 OSR > 1.063" Brg O.D/ 3.217" Stack-up	A-1	A	PT521HD
		2ISR & 2OSR > 1.063"/1.125" Bearing caps	A-1	B	PT675
CAPRI					
79-86	All Models	4 OSR > 1.063" Brg O.D/ 3.217" Stack-up	A-1	A / B	PT521HD
COLONY PARK					
1979	All Models - Towing Option	4 OSR > 1.063" Brg O.D/ 3.622" Stack-up	A-1	A / B	PT530
	All Models - Exc. Towing Option	4 OSR > 1.063" Brg O.D/ 3.217" Stack-up	A-1	A / B	PT521HD
70-76	All Models	4 OSR > 1.063" Brg O.D/ 3.622" Stack-up	A-1	A	PT530
		2 ISR & 2 OSR > 1.063"/1.125" Brg O.D/ 2.767" ISR	A-1	B	PT1204
COMET					
71-77	All Models	4 OSR > 1.063" Brg O.D/ 3.217" Stack-up	A-1	A	PT521HD
		2ISR & 2OSR > 1.063"/1.125" Bearing caps	A-1	B	PT675
COUGAR					
94-97	All Models	4 OSR > 1.063" Brg O.D/ 3.622" Stack-up	A-1	A / B	PT530
89-93	All Models - XR7	4 OSR > 1.063" Brg O.D/ 3.622" Stack-up	A-1	A / B	PT530
	All Models - Exc. XR7	4 OSR > 1.063" Brg O.D/ 3.217" Stack-up	A-1	A / B	PT521HD
83-88	All Models	4 OSR > 1.063" Brg O.D/ 3.217" Stack-up	A-1	A / B	PT521HD
80-82	All Models	4 OSR > 1.063" Brg O.D/ 3.217" Stack-up	F-1	A / B / C	PT521HD
1979	All Models	4 OSR > 1.063" Brg O.D/ 3.622" Stack-up	A-1	A	PT530
		4 ISR > 1.125" Brg O.D./2.555 Stack-up	A-1	A	PT3105
		2 ISR & 2 OSR > 1.063"/1.125" Brg O.D/ 2.767" ISR	A-1	B	PT1204
		2 ISR & 2 OSR > 1.125" Brg O.D./2.555" ISR - 3.622" OSR Stack-up	A-1	B	PT352
77-78	All Models	4 OSR > 1.063" Brg O.D/ 3.622" Stack-up	A-1	A	PT530
		2 ISR & 2 OSR > 1.063"/1.125" Brg O.D/ 2.767" ISR	A-1	B	PT1204

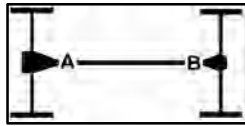

APPLICATION A-1

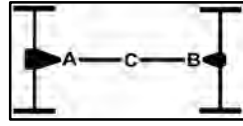

APPLICATION B-1

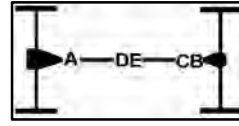

APPLICATION C-1

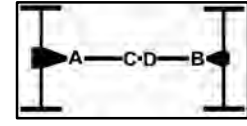

APPLICATION D-1

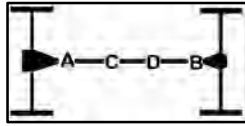

APPLICATION E-1

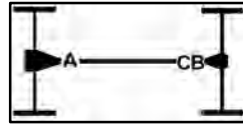

APPLICATION F-1

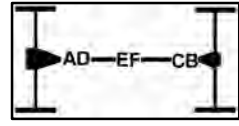

APPLICATION H-1

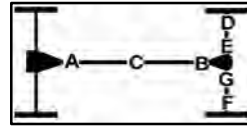

APPLICATION I-1

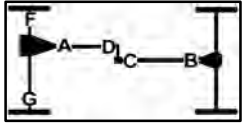

APPLICATION K-1

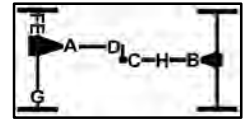

APPLICATION L-1

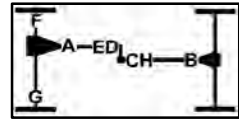

APPLICATION N-1

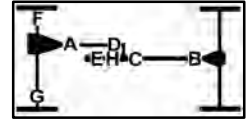

APPLICATION O-1

MAKE/YEARS FITMENT U-JOINT DESCRIPTION LOCATION POSITION PART NO.

MERCURY

MERCURY

MAKE/YEARS	FITMENT	U-JOINT DESCRIPTION	LOCATION	POSITION	PART NO.
COUGAR					
75-76	All Models - 5.8L V8, C4 A/T	4 OSR > 1.063" Brg O.D/ 3.622" Stack-up	A-1	A	PT530
		2ISR & 2OSR > 1.063"/1.125" Bearing caps	A-1	B	PT675
	All Models - Exc. 5.8L V8, C4 A/T	4 OSR > 1.063" Brg O.D/ 3.622" Stack-up	A-1	A	PT530
		2 ISR & 2 OSR > 1.063"/1.125" Brg O.D/ 2.767" ISR	A-1	B	PT1204
1974	All Models	4 OSR > 1.063" Brg O.D/ 3.622" Stack-up	A-1	A	PT530
		2 ISR & 2 OSR > 1.063"/1.125" Brg O.D/ 2.767" ISR	A-1	B	PT1204
1973	All Models	4 OSR > 1.063" Brg O.D/ 3.217" Stack-up	A-1	A	PT521HD
		2ISR & 2OSR > 1.063"/1.125" Bearing caps	A-1	B	PT675
71-72	All Models - 4 Spd. M/T	4 OSR > 1.063" Brg O.D/ 3.622" Stack-up	A-1	A	PT530
		2 ISR & 2 OSR > 1.063"/1.125" Brg O.D/ 2.767" ISR	A-1	B	PT1204
	All Models - Exc. 4 Spd. M/T	4 OSR > 1.063" Brg O.D/ 3.217" Stack-up	A-1	A	PT521HD
		2ISR & 2OSR > 1.063"/1.125" Bearing caps	A-1	B	PT675
1970	All Models - Standard 5.0L V8	4 OSR > 1.063" Brg O.D/ 3.217" Stack-up	A-1	A	PT521HD
		2ISR & 2OSR > 1.063"/1.125" Bearing caps	A-1	B	PT675
	All Models - Exc. Standard 5.0L V8	4 OSR > 1.063" Brg O.D/ 3.622" Stack-up	A-1	A	PT530
		2 ISR & 2 OSR > 1.063"/1.125" Brg O.D/ 2.767" ISR	A-1	B	PT1204
GRAND MARQUIS					
03-07	All Models	4 OSR > 1.063" Brg O.D/ 3.622" Stack-up	A-1	A / B	PT530
95-02	All Models	4 OSR > 1.063" Brg O.D/ 3.622" Stack-up	A-1	A / B	PT530
79-94	All Models - Towing Option	4 OSR > 1.063" Brg O.D/ 3.622" Stack-up	A-1	A / B	PT530
		All Models - Exc. Towing Option	4 OSR > 1.063" Brg O.D/ 3.217" Stack-up	A-1	A / B
77-78	All Models	4 OSR > 1.063" Brg O.D/ 3.217" Stack-up	A-1	A	PT521HD
		4 OSR > 1.063" Brg O.D/ 3.622" Stack-up	A-1	A	PT530
		2ISR & 2OSR > 1.063"/1.125" Bearing caps	A-1	B	PT675
		2 ISR & 2 OSR > 1.063"/1.125" Brg O.D/ 2.767" ISR	A-1	B	PT1204
75-76	All Models	4 OSR > 1.063" Brg O.D/ 3.622" Stack-up	A-1	A	PT530
		2 ISR & 2 OSR > 1.063"/1.125" Brg O.D/ 2.767" ISR	A-1	B	PT1204

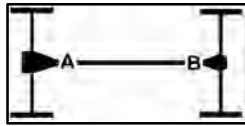

APPLICATION A-1

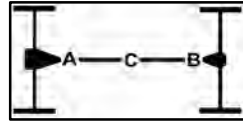

APPLICATION B-1

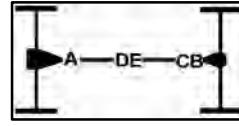

APPLICATION C-1

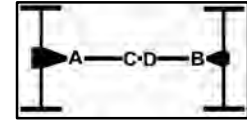

APPLICATION D-1

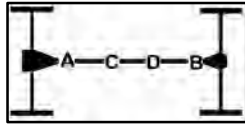

APPLICATION E-1

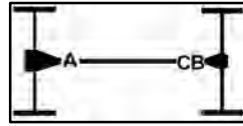

APPLICATION F-1

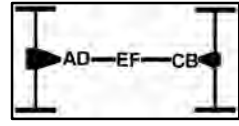

APPLICATION H-1

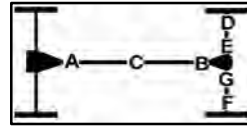

APPLICATION I-1

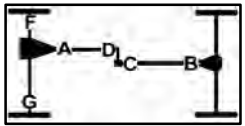

APPLICATION K-1

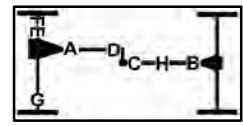

APPLICATION L-1

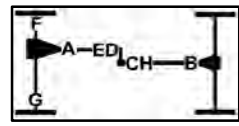

APPLICATION N-1



APPLICATION O-1

MAKE/YEARS FITMENT U-JOINT DESCRIPTION LOCATION POSITION PART NO.

MERCURY

MERCURY

MAKE/YEARS	FITMENT	U-JOINT DESCRIPTION	LOCATION	POSITION	PART NO.
MARAUDER					
03-04	All Models	4 OSR > 1.063" Brg O.D/ 3.622" Stack-up	A-1	A / B	PT530
1970	All Models	4 OSR > 1.063" Brg O.D/ 3.622" Stack-up	A-1	A	PT530
		2 ISR & 2 OSR > 1.063"/1.125" Brg O.D/ 2.767" ISR	A-1	B	PT1204
MARINER 4WD					
05-07	All Models	4 OSR > 1.063" Brg O.D/ 3.217" Stack-up	I-1	A / C	PT521HD
MARQUIS					
79-82	All Models - Towing Option	4 OSR > 1.063" Brg O.D/ 3.622" Stack-up	A-1	A / B	PT530
	All Models - Exc.Towing Option	4 OSR > 1.063" Brg O.D/ 3.217" Stack-up	A-1	A / B	PT521HD
77-78	All Models	4 OSR > 1.063" Brg O.D/ 3.217" Stack-up	A-1	A	PT521HD
		4 OSR > 1.063" Brg O.D/ 3.622" Stack-up	A-1	A	PT530
		2ISR & 2OSR > 1.063"/1.125" Bearing caps	A-1	B	PT675
		2 ISR & 2 OSR > 1.063"/1.125" Brg O.D/ 2.767" ISR	A-1	B	PT1204
70-76	All Models	4 OSR > 1.063" Brg O.D/ 3.622" Stack-up	A-1	A	PT530
		2 ISR & 2 OSR > 1.063"/1.125" Brg O.D/ 2.767" ISR	A-1	B	PT1204
MIDSIZE MARQUIS					
83-86	All Models - Towing Option	4 OSR > 1.063" Brg O.D/ 3.622" Stack-up	A-1	A / B	PT530
	All Models - Exc.Towing Option	4 OSR > 1.063" Brg O.D/ 3.217" Stack-up	A-1	A / B	PT521HD
MONARCH					
79-80	All Models	4 OSR > 1.063" Brg O.D/ 3.217" Stack-up	A-1	A	PT521HD
		2ISR & 2OSR > 1.063"/1.125" Bearing caps	A-1	B	PT675
75-78	All Models	4 OSR > 1.063" Brg O.D/ 3.217" Stack-up	A-1	A	PT521HD
		4 OSR > 1.063" Brg O.D/ 3.622" Stack-up	A-1	A	PT530
		2ISR & 2OSR > 1.063"/1.125" Bearing caps	A-1	B	PT675
		2 ISR & 2 OSR > 1.063"/1.125" Brg O.D/ 2.767" ISR	A-1	B	PT1204
MONTEGO					
70-76	All Models	4 OSR > 1.063" Brg O.D/ 3.217" Stack-up	A-1	A	PT521HD
		4 OSR > 1.063" Brg O.D/ 3.622" Stack-up	A-1	A	PT530
		2ISR & 2OSR > 1.063"/1.125" Bearing caps	A-1	B	PT675
		2 ISR & 2 OSR > 1.063"/1.125" Brg O.D/ 2.767" ISR	A-1	B	PT1204

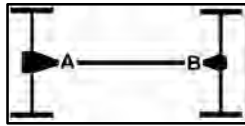

APPLICATION A-1

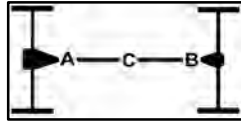

APPLICATION B-1

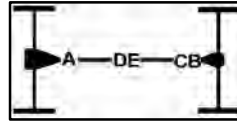

APPLICATION C-1

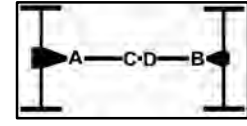

APPLICATION D-1

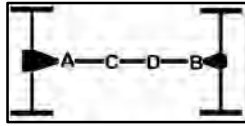

APPLICATION E-1

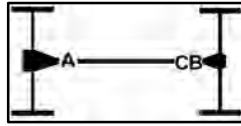

APPLICATION F-1

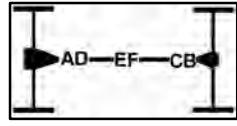

APPLICATION H-1

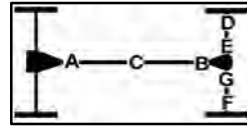

APPLICATION I-1

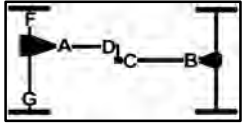

APPLICATION K-1

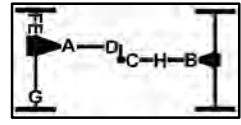

APPLICATION L-1

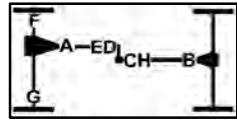

APPLICATION N-1

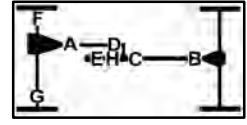

APPLICATION O-1

MAKE/YEARS FITMENT U-JOINT DESCRIPTION LOCATION POSITION PART NO.

MERCURY**MERCURY**

MONTEREY					
70-74 All Models	4 OSR > 1.063" Brg O.D/ 3.622" Stack-up	A-1	A	PT530	
	2 ISR & 2 OSR > 1.063"/1.125" Brg O.D/ 2.767" ISR	A-1	B	PT1204	
MOUNTAINEER 2WD					
97-07 All Models	4 OSR > 1.063" Brg O.D/ 3.622" Stack-up	A-1	A / B	PT530	
MOUNTAINEER 4WD					
97-07 All Models	4 OSR > 1.063" Brg O.D/ 3.217" Stack-up	L-1	A	PT521HD	
	4 OSR > 1.063" Brg O.D/ 3.622" Stack-up	L-1	B / C	PT530	
TOPAZ AWD					
87-91 All Models	4 OSR > 1.063" Brg O.D/2.437" Stack-up	I-1	A / B / C	PT315	
	4 OSR > 1.063" Brg O.D/2.437" Stack-up	I-1	D / E / F / G	PT315	
ZEPHYR					
78-83 All Models	4 OSR > 1.063" Brg O.D/ 3.217" Stack-up	A-1	A / B	PT521HD	

MITSUBISHI**MITSUBISHI**

MONTERO 4WD					
01-06 All Models	4 OSR > .985" Brg O.D./2.498" Stack-up	L-1	A	PT1601	
	4 OSR > .985" Brg O.D./3.030" Stack-up	L-1	A	PT1625	
99-00 All Models	4 OSR > .985" Brg O.D./2.498" Stack-up	L-1	A / D	PT1601	
	4 ISR > 1.181" Brg O.D./2.290" Stack-up	L-1	B / C	PT450	
97-98 All Models	4 OSR > .985" Brg O.D./3.030" Stack-up	L-1	A / D	PT1625	
	4 ISR > 1.181" Brg O.D./2.290" Stack-up	L-1	B / C	PT450	
94-96 All Models - 3.0L V6	4 OSR > .985" Brg O.D./2.498" Stack-up	L-1	A / D	PT1601	
	4 ISR > 1.181" Brg O.D./2.290" Stack-up	L-1	B / C	PT450	
	All Models - 3.5L V6				
	4 OSR > .985" Brg O.D./3.030" Stack-up	L-1	A / D	PT1625	
90-93 All Models	4 OSR > .985" Brg O.D./2.498" Stack-up	L-1	A / D	PT1601	
	4 ISR > 1.181" Brg O.D./2.290" Stack-up	L-1	B / C	PT450	

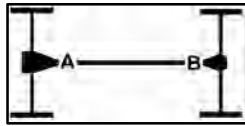

APPLICATION A-1

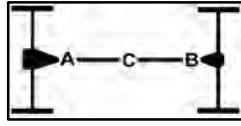

APPLICATION B-1

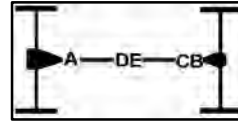

APPLICATION C-1

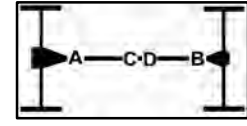

APPLICATION D-1

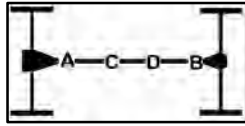

APPLICATION E-1

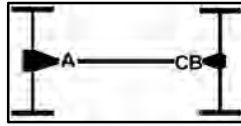

APPLICATION F-1

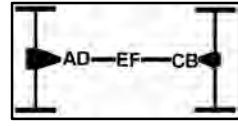

APPLICATION H-1

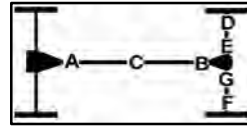

APPLICATION I-1

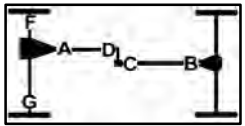

APPLICATION K-1

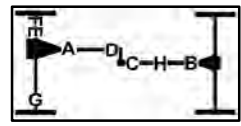

APPLICATION L-1

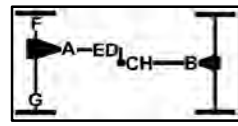

APPLICATION N-1



APPLICATION O-1

MAKE/YEARS FITMENT U-JOINT DESCRIPTION LOCATION POSITION PART NO.

MITSUBISHI

MITSUBISHI

MAKE/YEARS	FITMENT	U-JOINT DESCRIPTION	LOCATION	POSITION	PART NO.
MONTERO 4WD					
1989	All Models	4 OSR > .985" Brg O.D./2.498" Stack-up	L-1	A / D	PT1601
	All Models - 2.6L 4 Cyl.	4 OSR > .985" Brg O.D./3.030" Stack-up	L-1	B / C	PT1625
	All Models - 3.0L V6	4 ISR > 1.181" Brg O.D./2.290" Stack-up	L-1	B / C	PT450
83-88	All Models	4 OSR > .985" Brg O.D./2.498" Stack-up	L-1	A / D	PT1601
		4 OSR > .985" Brg O.D./3.030" Stack-up	L-1	B / C	PT1625
MONTERO SPORT 2WD					
00-04	All Models	4 ISR > 1.181" Brg O.D./2.290" Stack-up	B-1	A / B / C	PT450
97-99	All Models - 2.4L 4 Cyl.	4 OSR > .985" Brg O.D./3.030" Stack-up	B-1	A / B / C	PT1625
	All Models - Exc. 2.4L 4 Cyl.	4 ISR > 1.181" Brg O.D./2.290" Stack-up	B-1	A / B / C	PT450
MONTERO SPORT 4WD					
00-04	All Models	4 OSR > .985" Brg O.D./2.498" Stack-up	K-1	A	PT1601
		4 ISR > 1.181" Brg O.D./2.290" Stack-up	K-1	B / C	PT450
1999	All Models - 3.0L V6	4 OSR > .985" Brg O.D./2.498" Stack-up	K-1	A	PT1601
	All Models - 3.5L V6	4 OSR > .985" Brg O.D./3.030" Stack-up	K-1	A	PT1625
	All Models	4 ISR > 1.181" Brg O.D./2.290" Stack-up	K-1	B / C	PT450
97-98	All Models	4 OSR > .985" Brg O.D./2.498" Stack-up	K-1	A	PT1601
		4 ISR > 1.181" Brg O.D./2.290" Stack-up	K-1	B / C	PT450
OUTLANDER 2WD					
03-07	All Models	4 OSR > .985" Brg O.D./2.498" Stack-up	B-1	A / C	PT1601
OUTLANDER 4WD					
03-07	All Models	4 OSR > .985" Brg O.D./2.498" Stack-up	I-1	A / C	PT1601
PICKUP 2WD					
90-96	All Models - A/T	4 OSR > .985" Brg O.D./2.498" Stack-up	B-1	A / B / C	PT1601
	All Models - M/T	4 OSR > .985" Brg O.D./3.030" Stack-up	B-1	A / B / C	PT1625

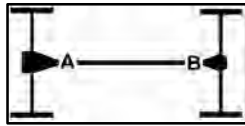

APPLICATION A-1

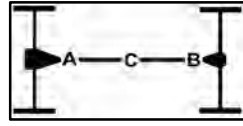

APPLICATION B-1

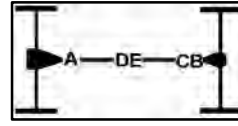

APPLICATION C-1

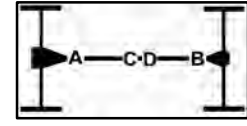

APPLICATION D-1

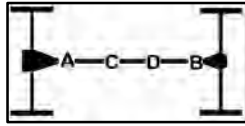

APPLICATION E-1

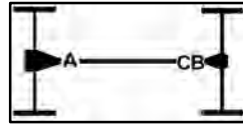

APPLICATION F-1

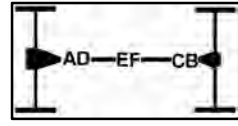

APPLICATION H-1

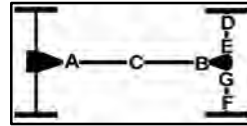

APPLICATION I-1

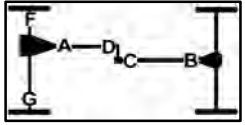

APPLICATION K-1

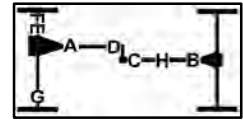

APPLICATION L-1

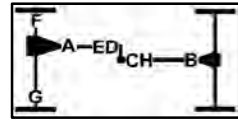

APPLICATION N-1

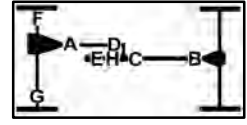

APPLICATION O-1

MAKE/YEARS FITMENT U-JOINT DESCRIPTION LOCATION POSITION PART NO.

MITSUBISHI**MITSUBISHI**

MAKE/YEARS	FITMENT	U-JOINT DESCRIPTION	LOCATION	POSITION	PART NO.
PICKUP 2WD					
83-89	All Models - 2.0L 4 Cyl. Engine	4 OSR > .985" Brg O.D./2.498" Stack-up	B-1	A / B / C	PT1601
	All Models - Exc. 2.0L 4 Cyl. Engine	4 OSR > .985" Brg O.D./3.030" Stack-up	B-1	A / B / C	PT1625
PICKUP 4WD					
90-96	All Models	4 OSR > .985" Brg O.D./2.498" Stack-up	L-1	A / D	PT1601
		4 ISR > 1.181" Brg O.D./2.290" Stack-up	L-1	B / C / H	PT450
83-89	All Models	4 OSR > .985" Brg O.D./2.498" Stack-up	L-1	A / D	PT1601
		4 OSR > .985" Brg O.D./3.030" Stack-up	L-1	B / C / H	PT1625
RAIDER 2WD					
06-07	All Models - 2 or 3 Joint Drive Shaft	4 OSR > 1.063" Brg O.D./ 3.622" Stack-up	B-1	A / B / C	PT530
RAIDER 4WD					
06-07	All Models	4 OSR > 1.063" Brg O.D./ 3.217" Stack-up	L-1	A	PT521HD
		4 OSR > 1.063" Brg O.D./ 3.622" Stack-up	L-1	B / C	PT530
VAN WAGON					
87-90	All Models	4 OSR > .985" Brg O.D./3.030" Stack-up	A-1	A / B	PT1625

NISSAN-DATSUN**NISSAN-DATSUN**

MAKE/YEARS	FITMENT	U-JOINT DESCRIPTION	LOCATION	POSITION	PART NO.
510					
78-81	All Models	4 ISR > .985" Brg O.D./1.731" Stack-up	A-1	A / B	PT1603
70-73	All Models	4 ISR > 1.102" Brg O.D./2.205" Stack-up	I-1	A / B	PT1602
		4 ISR > .985" Brg O.D./1.731" Stack-up	I-1	D / E / F / G	PT1603
610					
73-76	All Models	4 ISR > 1.102" Brg O.D./2.205" Stack-up	I-1	A / B	PT1602
		4 ISR > .985" Brg O.D./1.731" Stack-up	I-1	D / E / F / G	PT1603
710					
74-77	All Models	4 ISR > 1.102" Brg O.D./2.205" Stack-up	A-1	A / B	PT1602
810					
80-81	All Models	4 ISR > 1.102" Brg O.D./2.205" Stack-up	I-1	A / B	PT1602

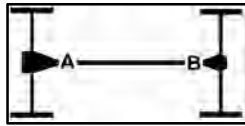

APPLICATION A-1

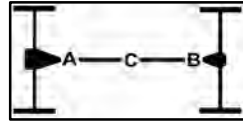

APPLICATION B-1

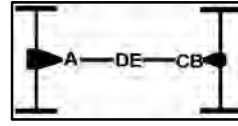

APPLICATION C-1

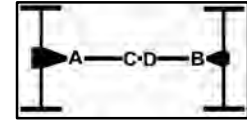

APPLICATION D-1

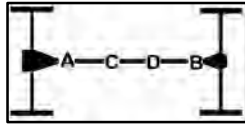

APPLICATION E-1

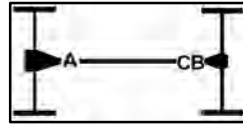

APPLICATION F-1

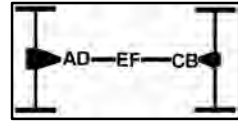

APPLICATION H-1

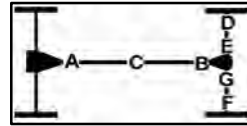

APPLICATION I-1

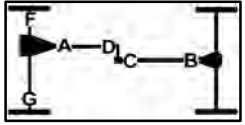

APPLICATION K-1

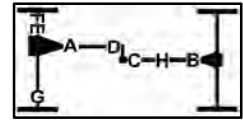

APPLICATION L-1

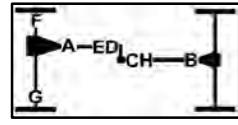

APPLICATION N-1

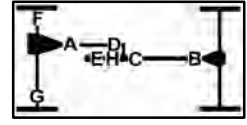

APPLICATION O-1

MAKE/YEARS FITMENT U-JOINT DESCRIPTION LOCATION POSITION PART NO.

NISSAN-DATSUN

NISSAN-DATSUN

MAKE/YEARS	FITMENT	U-JOINT DESCRIPTION	LOCATION	POSITION	PART NO.
240Z					
70-73	All Models	4 ISR > 1.102" Brg O.D./2.205" Stack-up	I-1	A / B	PT1602
		4 ISR > .985" Brg O.D./1.731" Stack-up	I-1	D / E / F / G	PT1603
260Z					
1974	All Models	4 ISR > 1.102" Brg O.D./2.205" Stack-up	I-1	A / B	PT1602
		4 ISR > .985" Brg O.D./1.731" Stack-up	I-1	D / E / F / G	PT1603
280Z					
75-78	All Models	4 ISR > .985" Brg O.D./1.731" Stack-up	I-1	D / E / F / G	PT1603
280ZX					
79-83	All Models	4 ISR > .985" Brg O.D./1.731" Stack-up	I-1	D / E / F / G	PT1603
D21 PICKUP 2WD					
96-97	All Models - 2 or 3 Joint Drive Shaft	4 ISR > 1.102" Brg O.D./2.205" Stack-up	B-1	A / B / C	PT1602
86-95	All Models - 2 or 3 Joint Drive Shaft - 4 Cyl. Eng.	4 ISR > 1.102" Brg O.D./2.205" Stack-up	B-1	A / B / C	PT1602
	All Models - 2 or 3 Joint Drive Shaft - 3.0L V6 Eng.	4 OSR > 1.063" Brg O.D/ 3.217" Stack-up	B-1	A / B / C	PT521HD
D21 PICKUP 4WD					
90-97	All Models	4 OSR > 1.063" Brg O.D/ 3.217" Stack-up	L-1	A / B / C / D	PT521HD
88-89	All Models - 4 Cyl. Eng.	4 ISR > .985" Brg O.D./1.731" Stack-up	L-1	A / D	PT1603
		4 ISR > 1.063" Brg O.D./1.930" Stack-up	L-1	B / C / H	PT446
	All Models - 3.0L V6 Eng.	4 ISR > 1.063" Brg O.D./1.930" Stack-up	L-1	A / D	PT446
		4 OSR > 1.063" Brg O.D/ 3.217" Stack-up	L-1	A / D	PT521HD
		4 ISR > 1.102" Brg O.D./2.205" Stack-up	L-1	B / C / H	PT1602
		4 OSR > 1.063" Brg O.D/ 3.217" Stack-up	L-1	B / C	PT521HD
86-87	All Models	4 ISR > 1.063" Brg O.D./1.930" Stack-up	L-1	A / D	PT446
		4 OSR > 1.063" Brg O.D/ 3.217" Stack-up	L-1	A / D	PT521HD
		4 ISR > 1.102" Brg O.D./2.205" Stack-up	L-1	B / C / H	PT1602
		4 OSR > 1.063" Brg O.D/ 3.217" Stack-up	L-1	B / C	PT521HD
FRONTIER PICKUP 2WD					
05-07	All Models	4 OSR > 1.063" Brg O.D/ 3.622" Stack-up	B-1	A / B / C	PT530
02-04	All Models - 2 or 3 Joint Drive Shaft	4 OSR > 1.063" Brg O.D/ 3.217" Stack-up	B-1	A / B / C	PT521HD

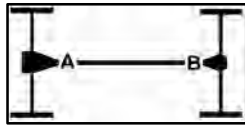

APPLICATION A-1

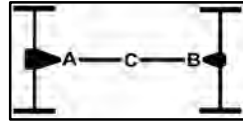

APPLICATION B-1

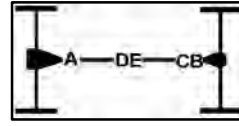

APPLICATION C-1

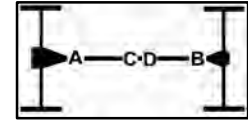

APPLICATION D-1

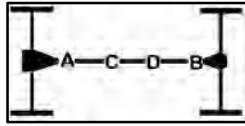

APPLICATION E-1

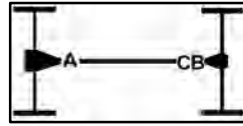

APPLICATION F-1

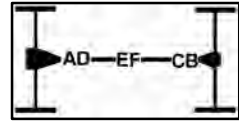

APPLICATION H-1

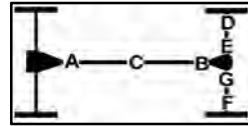

APPLICATION I-1

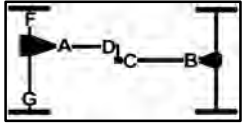

APPLICATION K-1

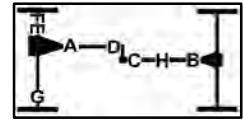

APPLICATION L-1

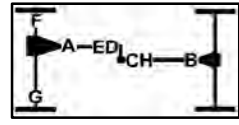

APPLICATION N-1



APPLICATION O-1

MAKE/YEARS FITMENT U-JOINT DESCRIPTION LOCATION POSITION PART NO.

NISSAN-DATSUN

NISSAN-DATSUN

MAKE/YEARS	FITMENT	U-JOINT DESCRIPTION	LOCATION	POSITION	PART NO.
FRONTIER PICKUP 4WD					
05-07	All Models	4 OSR > 1.063" Brg O.D/ 3.217" Stack-up	L-1	A / D	PT521HD
		4 OSR > 1.063" Brg O.D/ 3.622" Stack-up	L-1	B / C / H	PT530
98-04	All Models	4 OSR > 1.063" Brg O.D/ 3.217" Stack-up	L-1	A / B / C / D / H	PT521HD
PATHFINDER 2WD					
05-07	All Models	4 OSR > 1.063" Brg O.D/ 3.622" Stack-up	A-1	A / B	PT530
89-04	All Models	4 ISR > 1.102" Brg O.D./2.205" Stack-up	B-1	A / B / C	PT1602
PATHFINDER 4WD					
05-07	All Models	4 OSR > 1.063" Brg O.D/ 3.217" Stack-up	L-1	A / D	PT521HD
		4 OSR > 1.063" Brg O.D/ 3.622" Stack-up	L-1	B / C	PT530
87-04	All Models	4 ISR > 1.063" Brg O.D./1.930" Stack-up	L-1	A / D	PT446
		4 ISR > 1.102" Brg O.D./2.205" Stack-up	L-1	B / C	PT1602
PATHFINDER ARMADA 2WD					
04-07	All Models	4 OSR > 1.188" Brg O.D./3.622" Stack-up	B-1	A / B / C	PT578
PATHFINDER ARMADA 4WD					
04-07	All Models	4 OSR > 1.063" Brg O.D/ 3.217" Stack-up	K-1	A / D	PT521HD
		4 OSR > 1.188" Brg O.D./3.622" Stack-up	K-1	B / C	PT578
PL521 PICKUP					
70-72	All Models - 2 or 3 Joint Drive Shaft	4 ISR > .985" Brg O.D./1.731" Stack-up	B-1	A / B / C	PT1603
PL620 PICKUP					
72-79	All Models - 2 or 3 Joint Drive Shaft	4 ISR > .985" Brg O.D./1.731" Stack-up	B-1	A / B / C	PT1603
PL720 PICKUP 2WD					
80-86	All Models - 2 or 3 Joint Drive Shaft	4 ISR > .985" Brg O.D./1.731" Stack-up	B-1	A / B / C	PT1603
PL720 PICKUP 4WD					
84-86	All Models	4 ISR > 1.102" Brg O.D./2.205" Stack-up	O-1	A / D	PT1602
		4 ISR > 1.102" Brg O.D./2.205" Stack-up	O-1	B / C	PT1602
		4 ISR > 1.102" Brg O.D./2.205" Stack-up	O-1	E / H	PT1602
80-83	All Models	4 ISR > .985" Brg O.D./1.731" Stack-up	O-1	A / D	PT1603
		4 ISR > .985" Brg O.D./1.731" Stack-up	O-1	B / C	PT1603
		4 ISR > .985" Brg O.D./1.731" Stack-up	O-1	E / H	PT1603

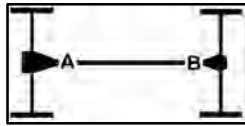

APPLICATION A-1

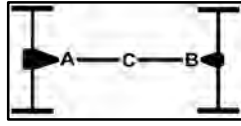

APPLICATION B-1

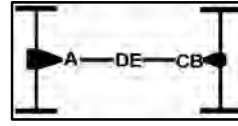

APPLICATION C-1

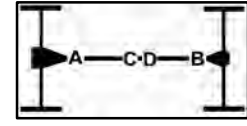

APPLICATION D-1

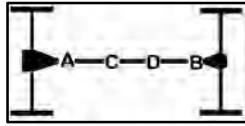

APPLICATION E-1

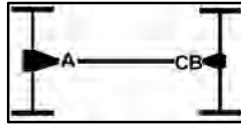

APPLICATION F-1

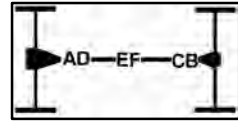

APPLICATION H-1

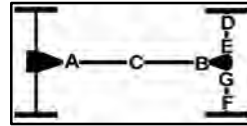

APPLICATION I-1

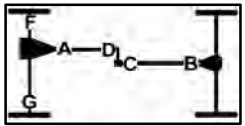

APPLICATION K-1

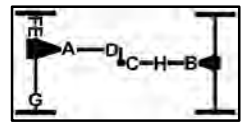

APPLICATION L-1

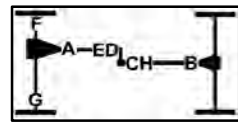

APPLICATION N-1



APPLICATION O-1

MAKE/YEARS FITMENT U-JOINT DESCRIPTION LOCATION POSITION PART NO.

NISSAN-DATSUN

NISSAN-DATSUN

TITAN 2WD					
04-07	All Models	4 OSR > 1.188" Brg O.D./3.622" Stack-up	B-1	A / B / C	PT578
TITAN 4WD					
04-07	All Models	4 OSR > 1.063" Brg O.D/ 3.217" Stack-up	K-1	A / D	PT521HD
		4 OSR > 1.188" Brg O.D./3.622" Stack-up	K-1	B / C	PT578

OLDSMOBILE

OLDSMOBILE

BRAVADA 2WD					
02-04	All Models	4 ISR > 1.125" Brg O.D./2.555 Stack-up	A-1	A / B	PT3105
BRAVADA 4WD					
02-04	All Models	2 ISR & 2 OSR > 1.063" Brg O.D/ 3.217" OSR - 2.344" ISR Stack-up	L-1	A	PT445
		4 ISR > 1.125" Brg O.D./2.555 Stack-up	L-1	B / C	PT3105
96-01	All Models	4 ISR > 1.125" Brg O.D./2.555 Stack-up	L-1	B / C / D / E	PT3105
91-94	All Models	4 OSR > 1.063" Brg O.D/ 3.217" Stack-up	N-1	D / E	PT521HD
		4 ISR > 1.125" Brg O.D./2.555 Stack-up	N-1	B / C	PT3105
CUTLASS (Includes S, Salon, Supreme, Supreme Cruiser, Calais)					
82-88	All Models	4 ISR > 1.125" Brg O.D./2.555 Stack-up	A-1	A / B	PT3105
		4 OSR > 1.188" Brg O.D./3.622" Stack-up	A-1	A / B	PT578
71-81	All Models	4 ISR > 1.125" Brg O.D./2.555 Stack-up	A-1	A / B	PT3105
1970	All Models - V8-455 Eng.	4 OSR > 1.063" Brg O.D/ 3.622" Stack-up	A-1	A	PT530
		2 ISR & 2 OSR > 1.063"/1.125" Brg O.D/ 2.555" ISR	A-1	B	PT3188
	All Models - Exc. V8-455 Eng.	4 ISR > 1.125" Brg O.D./2.555 Stack-up	A-1	A / B	PT3105
CUSTOM CRUISER RWD					
85-92	All Models	4 ISR > 1.125" Brg O.D./2.555 Stack-up	A-1	A / B	PT3105
71-79	All Models	4 ISR > 1.125" Brg O.D./2.555 Stack-up	A-1	A / B	PT3105

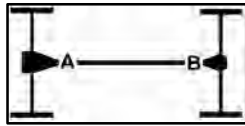

APPLICATION A-1

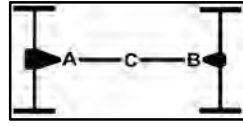

APPLICATION B-1

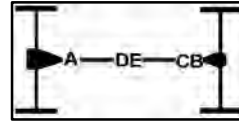

APPLICATION C-1

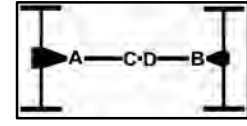

APPLICATION D-1

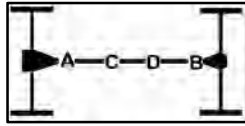

APPLICATION E-1

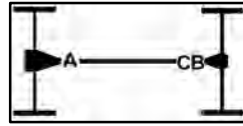

APPLICATION F-1

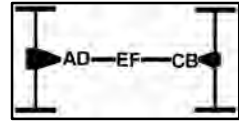

APPLICATION H-1

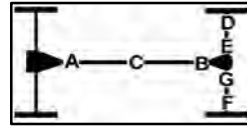

APPLICATION I-1

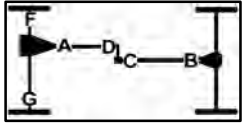

APPLICATION K-1

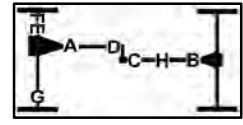

APPLICATION L-1

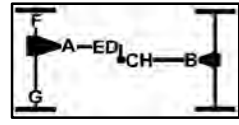

APPLICATION N-1

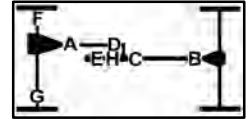

APPLICATION O-1

MAKE/YEARS FITMENT U-JOINT DESCRIPTION LOCATION POSITION PART NO.

OLDSMOBILE

OLDSMOBILE

MAKE/YEARS	FITMENT	U-JOINT DESCRIPTION	LOCATION	POSITION	PART NO.
DELTA 88 RWD					
85-88	All Models	4 ISR > 1.125" Brg O.D./2.555 Stack-up	A-1	A / B	PT3105
82-84	All Models	4 ISR > 1.125" Brg O.D./2.555 Stack-up	A-1	A / B	PT3105
		4 OSR > 1.188" Brg O.D./3.622" Stack-up	A-1	A / B	PT578
71-81	All Models	4 ISR > 1.125" Brg O.D./2.555 Stack-up	A-1	A / B	PT3105
1970	All Models - V8-455 Eng.	4 OSR > 1.063" Brg O.D/ 3.622" Stack-up	A-1	A	PT530
		2 ISR & 2 OSR > 1.063"/1.125" Brg O.D/ 2.555" ISR	A-1	B	PT3188
		All Models - Exc. V8-455 Eng.	4 ISR > 1.125" Brg O.D./2.555 Stack-up	A-1	A / B
F85					
71-72	All Models	4 ISR > 1.125" Brg O.D./2.555 Stack-up	A-1	A / B	PT3105
1970	All Models - V8-455 Eng.	4 OSR > 1.063" Brg O.D/ 3.622" Stack-up	A-1	A	PT530
		2 ISR & 2 OSR > 1.063"/1.125" Brg O.D/ 2.555" ISR	A-1	B	PT3188
		All Models - Exc. V8-455 Eng.	4 ISR > 1.125" Brg O.D./2.555 Stack-up	A-1	A / B
LUXURY 98 RWD					
71-79	All Models	4 ISR > 1.125" Brg O.D./2.555 Stack-up	A-1	A / B	PT3105
1970	All Models - V8-455 Eng.	4 OSR > 1.063" Brg O.D/ 3.622" Stack-up	A-1	A	PT530
		2 ISR & 2 OSR > 1.063"/1.125" Brg O.D/ 2.555" ISR	A-1	B	PT3188
		All Models - Exc. V8-455 Eng.	4 ISR > 1.125" Brg O.D./2.555 Stack-up	A-1	A / B
NINETY EIGHT RWD					
82-84	All Models	4 ISR > 1.125" Brg O.D./2.555 Stack-up	A-1	A / B	PT3105
		4 OSR > 1.188" Brg O.D./3.622" Stack-up	A-1	A / B	PT578
73-81	All Models	4 ISR > 1.125" Brg O.D./2.555 Stack-up	A-1	A / B	PT3105
OLDS 98 RWD					
71-75	All Models	4 ISR > 1.125" Brg O.D./2.555 Stack-up	A-1	A / B	PT3105
1970	All Models - V8-455 Eng.	4 OSR > 1.063" Brg O.D/ 3.622" Stack-up	A-1	A	PT530
		2 ISR & 2 OSR > 1.063"/1.125" Brg O.D/ 2.555" ISR	A-1	B	PT3188
		All Models - Exc. V8-455 Eng.	4 ISR > 1.125" Brg O.D./2.555 Stack-up	A-1	A / B

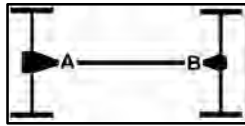

APPLICATION A-1

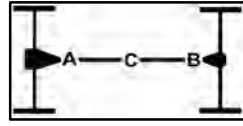

APPLICATION B-1

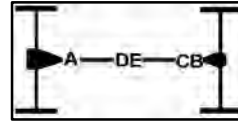

APPLICATION C-1

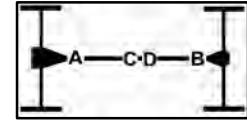

APPLICATION D-1

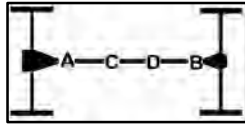

APPLICATION E-1

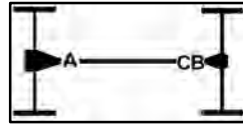

APPLICATION F-1

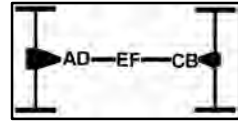

APPLICATION H-1

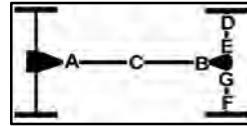

APPLICATION I-1

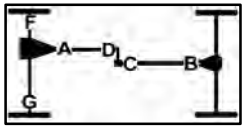

APPLICATION K-1

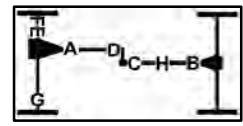

APPLICATION L-1

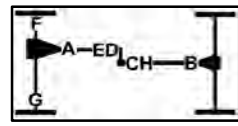

APPLICATION N-1



APPLICATION O-1

MAKE/YEARS FITMENT U-JOINT DESCRIPTION LOCATION POSITION PART NO.

OLDSMOBILE

OLDSMOBILE

MAKE/YEARS	FITMENT	U-JOINT DESCRIPTION	LOCATION	POSITION	PART NO.
OMEGA					
77-79	All Models	4 OSR > 1.063" Brg O.D/ 3.217" Stack-up	A-1	A / B	PT521HD
1976	All Models - 5 Spd. M/T	4 ISR > 1.125" Brg O.D./2.555 Stack-up	A-1	A / B	PT3105
	All Models - Exc. 5 Spd. M/T	4 OSR > 1.063" Brg O.D/ 3.217" Stack-up	A-1	A / B	PT521HD
73-75	All Models	4 OSR > 1.063" Brg O.D/ 3.217" Stack-up	A-1	A / B	PT521HD
REGENCY 98					
73-79	All Models	4 ISR > 1.125" Brg O.D./2.555 Stack-up	A-1	A / B	PT3105
STARFIRE					
75-80	All Models	4 OSR > 1.063" Brg O.D/ 3.217" Stack-up	A-1	A / B	PT521HD
1976	All Models - 5 Spd. M/T	4 ISR > 1.125" Brg O.D./2.555 Stack-up	A-1	A / B	PT3105
	All Models - Exc. 5 Spd. M/T	4 OSR > 1.063" Brg O.D/ 3.217" Stack-up	A-1	A / B	PT521HD
1975	All Models	4 OSR > 1.063" Brg O.D/ 3.217" Stack-up	A-1	A / B	PT521HD
SUPREME CRUISER					
74-76	All Models	4 ISR > 1.125" Brg O.D./2.555 Stack-up	A-1	A / B	PT3105
VISTA CRUISER					
71-77	All Models	4 ISR > 1.125" Brg O.D./2.555 Stack-up	A-1	A / B	PT3105
1970	All Models - V8-455 Eng.	4 OSR > 1.063" Brg O.D/ 3.622" Stack-up	A-1	A	PT530
		2 ISR & 2 OSR > 1.063"/1.125" Brg O.D/ 2.555" ISR	A-1	B	PT3188
	All Models - Exc. V8-455 Eng.	4 ISR > 1.125" Brg O.D./2.555 Stack-up	A-1	A / B	PT3105

PLYMOUTH

PLYMOUTH

MAKE/YEARS	FITMENT	U-JOINT DESCRIPTION	LOCATION	POSITION	PART NO.
ARROW					
76-79	All Models	4 OSR > .985" Brg O.D./2.498" Stack-up	A-1	A / B	PT1601
ARROW PICKUP					
79-83	All Models	4 OSR > .985" Brg O.D./2.498" Stack-up	A-1	A / B	PT1601

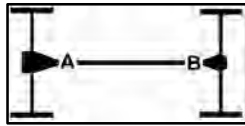

APPLICATION A-1

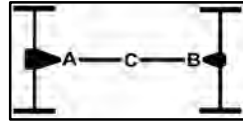

APPLICATION B-1

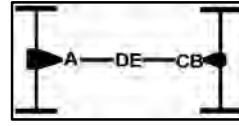

APPLICATION C-1

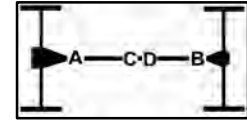

APPLICATION D-1

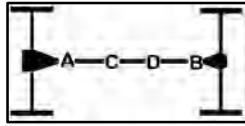

APPLICATION E-1

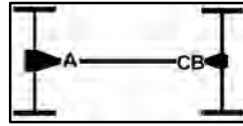

APPLICATION F-1

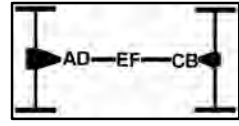

APPLICATION H-1

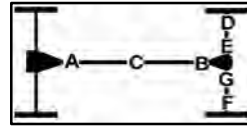

APPLICATION I-1

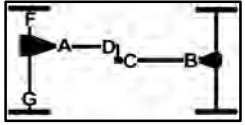

APPLICATION K-1

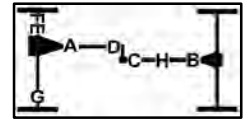

APPLICATION L-1

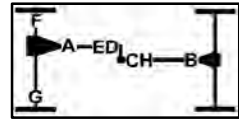

APPLICATION N-1

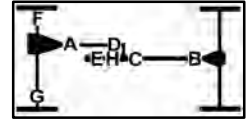

APPLICATION O-1

MAKE/YEARS FITMENT U-JOINT DESCRIPTION LOCATION POSITION PART NO.

PLYMOUTH

PLYMOUTH

MAKE/YEARS	FITMENT	U-JOINT DESCRIPTION	LOCATION	POSITION	PART NO.
BARRACUDA					
70-75	All Models	4 ISR > 1.078" Brg O.D./2.121" Stack-up	A-1	A / B	PT266
		4 ISR > 1.125" Brg O.D./2.619" Stack-up	A-1	A / B	PT231
BELVEDERE					
1970	All Models	4 ISR > 1.078" Brg O.D./2.121" Stack-up	A-1	A / B	PT266
		4 ISR > 1.125" Brg O.D./2.619" Stack-up	A-1	A / B	PT231
CONQUEST					
84-86	All Models	4 OSR > .985" Brg O.D./3.030" Stack-up	A-1	A / B	PT1625
CRICKET					
71-73	All Models	4 OSR > .938" Brg O.D. / 2.407" Stack-up	A-1	A / B	PT514
DUSTER					
70-76	All Models	4 ISR > 1.078" Brg O.D./2.121" Stack-up	A-1	A / B	PT266
		4 ISR > 1.125" Brg O.D./2.619" Stack-up	A-1	A / B	PT231
FURY (FULL SIZE)					
1978	All Models	4 ISR > 1.078" Brg O.D./2.121" Stack-up	A-1	A / B	PT266
		4 ISR > 1.125" Brg O.D./2.619" Stack-up	A-1	A / B	PT231
70-75	All Models	4 ISR > 1.078" Brg O.D./2.121" Stack-up	A-1	A / B	PT266
		4 ISR > 1.125" Brg O.D./2.619" Stack-up	A-1	A / B	PT231
GRAN FURY					
80-89	All Models	4 ISR > 1.078" Brg O.D./2.121" Stack-up	A-1	A / B	PT266
74-77	All Models	4 ISR > 1.078" Brg O.D./2.121" Stack-up	A-1	A / B	PT266
		4 ISR > 1.125" Brg O.D./2.619" Stack-up	A-1	A / B	PT231
ROADRUNNER					
70-74	All Models	4 ISR > 1.078" Brg O.D./2.121" Stack-up	A-1	A / B	PT266
		4 ISR > 1.125" Brg O.D./2.619" Stack-up	A-1	A / B	PT231
SAPPORO					
78-83	All Models	4 OSR > .985" Brg O.D./3.030" Stack-up	A-1	A / B	PT1625
SATELLITE					
70-74	All Models	4 ISR > 1.078" Brg O.D./2.121" Stack-up	A-1	A / B	PT266
		4 ISR > 1.125" Brg O.D./2.619" Stack-up	A-1	A / B	PT231

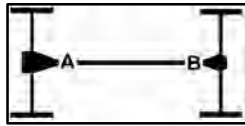

APPLICATION A-1

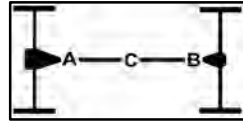

APPLICATION B-1

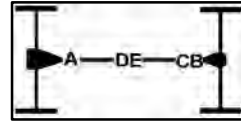

APPLICATION C-1

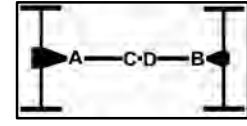

APPLICATION D-1

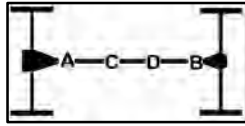

APPLICATION E-1

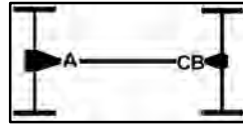

APPLICATION F-1

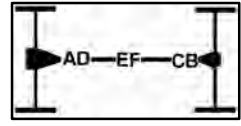

APPLICATION H-1

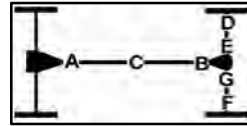

APPLICATION I-1

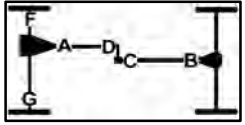

APPLICATION K-1

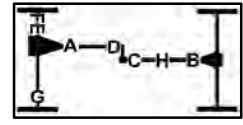

APPLICATION L-1

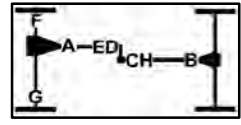

APPLICATION N-1

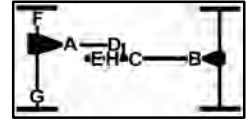

APPLICATION O-1

MAKE/YEARS FITMENT U-JOINT DESCRIPTION LOCATION POSITION PART NO.

PLYMOUTH

PLYMOUTH

SCAMP					
71-76 All Models	4 ISR > 1.078" Brg O.D./2.121" Stack-up	A-1	A / B	PT266	
	4 ISR > 1.125" Brg O.D./2.619" Stack-up	A-1	A / B	PT231	
TRAILDUSTER 2WD					
74-81 All Models	4 ISR > 1.078" Brg O.D./2.121" Stack-up	A-1	A / B	PT266	
	4 ISR > 1.125" Brg O.D./2.619" Stack-up	A-1	A / B	PT231	
TRAILDUSTER 4WD					
74-81 All Models	4 ISR > 1.125" Brg O.D./2.555 Stack-up	N-1	D / E	PT3105	
	4 OSR > 1.063" Brg O.D./ 3.217" Stack-up	N-1	D / E	PT521HD	
	4 ISR > 1.078" Brg O.D./2.121" Stack-up	N-1	A / B / C / H	PT266	
	4 ISR > 1.125" Brg O.D./2.619" Stack-up	N-1	B	PT231	
	4 ISR > 1.188" Brg O.D./2.187" Stack-up	N-1	F / G	PT297	
VALIANT					
70-76 All Models	4 ISR > 1.078" Brg O.D./2.121" Stack-up	A-1	A / B	PT266	
	4 ISR > 1.125" Brg O.D./2.619" Stack-up	A-1	A / B	PT231	
VOLARE					
76-79 All Models	4 ISR > 1.078" Brg O.D./2.121" Stack-up	A-1	A / B	PT266	
	4 ISR > 1.125" Brg O.D./2.619" Stack-up	A-1	A / B	PT231	

PONTIAC

PONTIAC

6000 AWD					
82-91 All Models	4 OSR > 1.063" Brg O.D./2.437" Stack-up	D-1	C / D	PT315	
	4 ISR > 1.125" Brg O.D./2.555 Stack-up	D-1	B	PT3105	
ASTRE					
75-77 All Models	4 OSR > 1.063" Brg O.D./ 3.217" Stack-up	A-1	A / B	PT521HD	
BONNEVILLE RWD					
85-89 All Models	4 ISR > 1.125" Brg O.D./2.555 Stack-up	A-1	A / B	PT3105	
	4 OSR > 1.188" Brg O.D./3.622" Stack-up	A-1	A / B	PT578	
82-84 All Models	4 OSR > 1.188" Brg O.D./3.622" Stack-up	A-1	A / B	PT578	
70-81 All Models	4 ISR > 1.125" Brg O.D./2.555 Stack-up	A-1	A / B	PT3105	

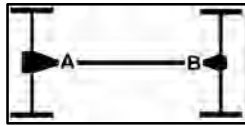

APPLICATION A-1

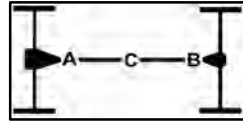

APPLICATION B-1

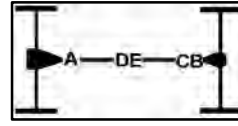

APPLICATION C-1

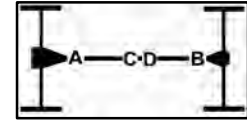

APPLICATION D-1

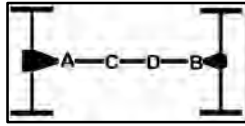

APPLICATION E-1

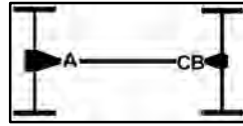

APPLICATION F-1

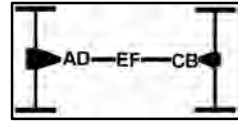

APPLICATION H-1

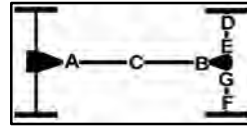

APPLICATION I-1

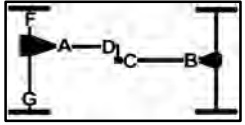

APPLICATION K-1

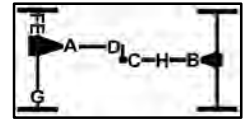

APPLICATION L-1

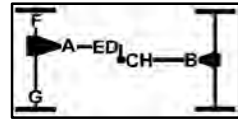

APPLICATION N-1

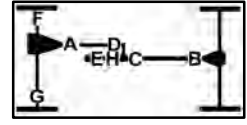

APPLICATION O-1

MAKE/YEARS FITMENT U-JOINT DESCRIPTION LOCATION POSITION PART NO.

PONTIAC

PONTIAC

MAKE/YEARS	FITMENT	U-JOINT DESCRIPTION	LOCATION	POSITION	PART NO.
CATALINA RWD					
70-81	All Models	4 ISR > 1.125" Brg O.D./2.555 Stack-up	A-1	A / B	PT3105
EXECUTIVE RWD					
1970	All Models	4 ISR > 1.125" Brg O.D./2.555 Stack-up	A-1	A / B	PT3105
FIREBIRD					
94-02	All Models	4 ISR > 1.125" Brg O.D./2.555 Stack-up	A-1	A / B	PT3105
88-93	All Models - Aluminum Drive Shaft	4 OSR > 1.063" Brg O.D/ 3.217" Stack-up	A-1	A	PT521HD
		2 ISR & 2 OSR > 1.063"/1.125" Brg O.D/ 3.217" Stack-up	A-1	B	PT356
	All Models - Steel Drive Shaft	4 ISR > 1.125" Brg O.D./2.555 Stack-up	A-1	A / B	PT3105
85-87	All Models	4 ISR > 1.125" Brg O.D./2.555 Stack-up	A-1	A / B	PT3105
82-84	All Models	4 ISR > 1.125" Brg O.D./2.555 Stack-up	A-1	A / B	PT3105
		4 OSR > 1.188" Brg O.D./3.622" Stack-up	A-1	A / B	PT578
76-81	All Models	4 ISR > 1.125" Brg O.D./2.555 Stack-up	A-1	A / B	PT3105
70-75	All Models	4 OSR > 1.063" Brg O.D/ 3.217" Stack-up	A-1	A / B	PT521HD
GRAND PRIX					
85-87	All Models	4 ISR > 1.125" Brg O.D./2.555 Stack-up	A-1	A / B	PT3105
82-84	All Models	4 ISR > 1.125" Brg O.D./2.555 Stack-up	A-1	A / B	PT3105
		4 OSR > 1.188" Brg O.D./3.622" Stack-up	A-1	A / B	PT578
70-81	All Models	4 ISR > 1.125" Brg O.D./2.555 Stack-up	A-1	A / B	PT3105
GRAND SAFARI RWD					
71-78	All Models	4 ISR > 1.125" Brg O.D./2.555 Stack-up	A-1	A / B	PT3105
GRANDVILLE RWD					
71-75	All Models	4 ISR > 1.125" Brg O.D./2.555 Stack-up	A-1	A / B	PT3105
LEMANS RWD					
70-81	All Models	4 ISR > 1.125" Brg O.D./2.555 Stack-up	A-1	A / B	PT3105

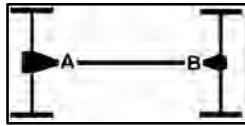

APPLICATION A-1

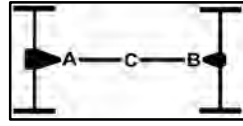

APPLICATION B-1

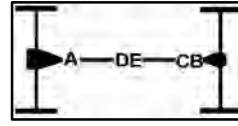

APPLICATION C-1

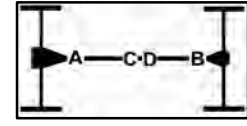

APPLICATION D-1

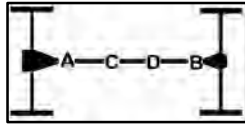

APPLICATION E-1

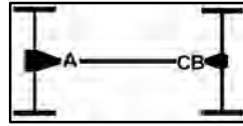

APPLICATION F-1

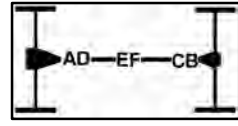

APPLICATION H-1

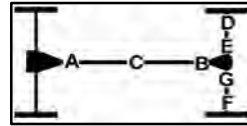

APPLICATION I-1

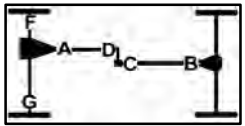

APPLICATION K-1

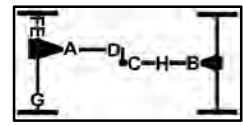

APPLICATION L-1

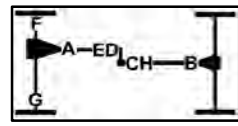

APPLICATION N-1



APPLICATION O-1

MAKE/YEARS FITMENT U-JOINT DESCRIPTION LOCATION POSITION PART NO.

PONTIAC**PONTIAC**

PARISIENNE					
85-86 All Models	4 ISR > 1.125" Brg O.D./2.555 Stack-up	A-1	A / B	PT3105	
83-84 All Models	4 ISR > 1.125" Brg O.D./2.555 Stack-up	A-1	A / B	PT3105	
	4 OSR > 1.188" Brg O.D./3.622" Stack-up	A-1	A / B	PT578	
PHOENIX					
77-79 All Models	4 OSR > 1.063" Brg O.D/ 3.217" Stack-up	A-1	A / B	PT521HD	
SAFARI RWD					
87-89 All Models	4 ISR > 1.125" Brg O.D./2.555 Stack-up	A-1	A / B	PT3105	
SUNBIRD					
76-80 All Models	4 OSR > 1.063" Brg O.D/ 3.217" Stack-up	A-1	A / B	PT521HD	
T1000					
81-87 All Models	4 ISR > 1.063" Brg O.D./2.341" Stack-up	A-1	A / B	PT350	
VENTURA					
1977 All Models	4 ISR > 1.125" Brg O.D./2.555 Stack-up	A-1	A	PT3105	
	4 OSR > 1.063" Brg O.D/ 3.217" Stack-up	A-1	A / B	PT521HD	
70-76 All Models	4 OSR > 1.063" Brg O.D/ 3.217" Stack-up	A-1	A / B	PT521HD	

SUZUKI**SUZUKI**

GRAND VITARA 2WD					
99-05 All Models - A/T	4 OSR > .985" Brg O.D./2.498" Stack-up	A-1	A / B	PT1601	
All Models - M/T	4 OSR > 1.024" Brg O.D./2.756" Stack-up	A-1	A / B	PT408	
GRAND VITARA 4WD					
99-05 All Models	4 OSR > .985" Brg O.D./2.498" Stack-up	L-1	A / B / C / D	PT1601	
	4 OSR > 1.024" Brg O.D./2.756" Stack-up	L-1	B / C	PT408	
SAMURAI 4WD					
90-95 All Models	4 OSR > .985" Brg O.D./2.498" Stack-up	O-1	A / D	PT1601	
	4 OSR > .985" Brg O.D./2.498" Stack-up	O-1	B / C	PT1601	
	4 OSR > .985" Brg O.D./2.498" Stack-up	O-1	E / H	PT1601	

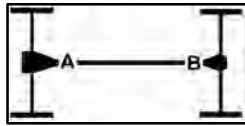

APPLICATION A-1

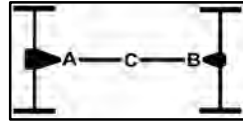

APPLICATION B-1

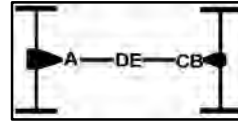

APPLICATION C-1

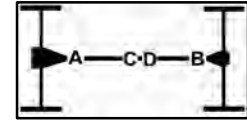

APPLICATION D-1

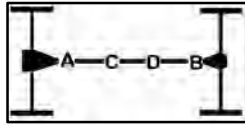

APPLICATION E-1

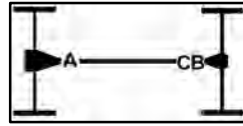

APPLICATION F-1

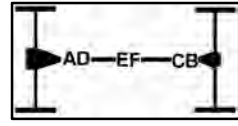

APPLICATION H-1

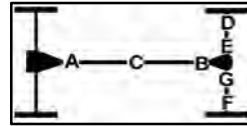

APPLICATION I-1

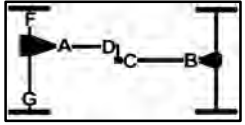

APPLICATION K-1

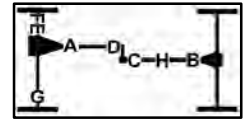

APPLICATION L-1

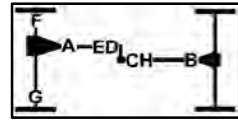

APPLICATION N-1

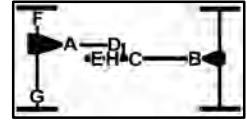

APPLICATION O-1

MAKE/YEARS FITMENT U-JOINT DESCRIPTION LOCATION POSITION PART NO.

SUZUKI

SUZUKI

SUZUKI					
SIDEKICK 2WD					
90-98	All Models	4 OSR > .985" Brg O.D./2.498" Stack-up	A-1	A / B	PT1601
SIDEKICK 4WD					
90-98	All Models	4 OSR > .985" Brg O.D./2.498" Stack-up	L-1	A / B / C / D	PT1601
VITARA 2WD					
99-04	All Models	4 OSR > .985" Brg O.D./2.498" Stack-up	A-1	A / B	PT1601
VITARA 4WD					
99-04	All Models	4 OSR > .985" Brg O.D./2.498" Stack-up	L-1	A / B / C / D	PT1601
XL-7 2WD					
01-05	All Models	4 OSR > 1.024" Brg O.D./2.756" Stack-up	A-1	A / B	PT408
XL-7 4WD					
01-05	All Models	4 OSR > .985" Brg O.D./2.498" Stack-up	L-1	A / D	PT1601
		4 OSR > 1.024" Brg O.D./2.756" Stack-up	L-1	C	PT408

TOYOTA

TOYOTA

TOYOTA					
4RUNNER 2WD					
90-04	All Models	4 ISR > 1.142" Brg O.D./2.049" Stack-up	A-1	A / B	PT1619
4RUNNER 4WD					
84-04	All Models	4 ISR > 1.142" Brg O.D./2.049" Stack-up	N-1	A / B / C / D / E	PT1619
		4 ISR > 1.125" Brg O.D./2.125" Stack-up	N-1	D / E	PT2500
CARINA					
72-73	All Models	4 ISR > 1.024" Brg O.D./1.844" Stack-up	A-1	A / B	PT1605
CELICA					
71-81	All Models - 2 or 3 Joint Drive Shaft	4 ISR > 1.024" Brg O.D./1.844" Stack-up	B-1	A / B / C	PT1605
COROLLA RWD					
70-79	All Models - 1.2L Eng.	4 ISR > .788" Brg O.D./1.494" Stack-up	A-1	A / B	PT1604
	All Models - 1.6L Eng.	4 ISR > 1.024" Brg O.D./1.844" Stack-up	A-1	A / B	PT1605

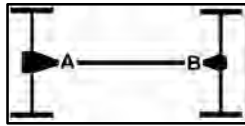

APPLICATION A-1

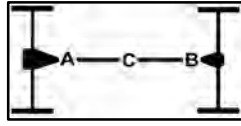

APPLICATION B-1

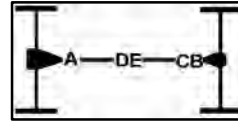

APPLICATION C-1

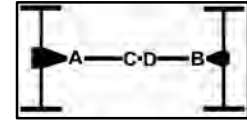

APPLICATION D-1

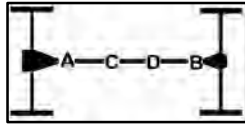

APPLICATION E-1

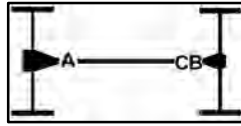

APPLICATION F-1

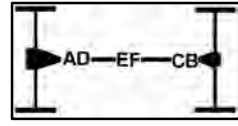

APPLICATION H-1

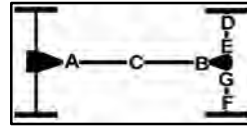

APPLICATION I-1

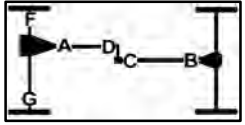

APPLICATION K-1

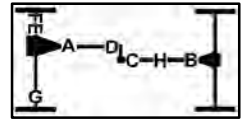

APPLICATION L-1

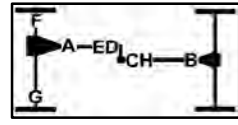

APPLICATION N-1

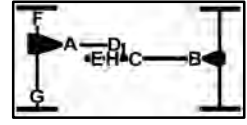

APPLICATION O-1

MAKE/YEARS FITMENT U-JOINT DESCRIPTION LOCATION POSITION PART NO.

TOYOTA

TOYOTA

MAKE/YEARS	FITMENT	U-JOINT DESCRIPTION	LOCATION	POSITION	PART NO.
CORONA					
70-82	All Models - 2 or 3 Joint Drive Shaft	4 ISR > 1.024" Brg O.D./1.844" Stack-up	B-1	A / B / C	PT1605
CRESSIDA					
78-92	All Models - 2 or 3 Joint Drive Shaft - Wagon or Sedan	4 ISR > 1.024" Brg O.D./1.844" Stack-up	B-1	A / B / C	PT1605
CROWN					
70-72	All Models - 2 or 3 Joint Drive Shaft	4 ISR > 1.142" Brg O.D./2.049" Stack-up	B-1	A / B / C	PT1619
HILUX PICKUP 2WD					
89-95	All Models	4 ISR > 1.142" Brg O.D./2.049" Stack-up	B-1	A / B / C	PT1619
		4 OSR > 1.063" Brg O.D./ 3.217" Stack-up	B-1	A / B / C	PT521HD
79-88	All Models	4 ISR > 1.142" Brg O.D./2.049" Stack-up	B-1	A / B / C	PT1619
		4 ISR > 1.024" Brg O.D./2.197" Stack-up	B-1	A / B / C	PT1616
70-78	All Models	4 ISR > 1.024" Brg O.D./2.197" Stack-up	B-1	A / B / C	PT1616
HILUX PICKUP 4WD					
79-95	All Models	4 ISR > 1.142" Brg O.D./2.049" Stack-up	N-1	A / B / C / D / E	PT1619
		4 ISR > 1.125" Brg O.D./2.125" Stack-up	N-1	D / E / H	PT2500
LAND CRUISER 4WD					
98-05	All Models	4 ISR > 1.142" Brg O.D./2.049" Stack-up	K-1	A / B / C / D	PT1619
74-97	All Models	4 ISR > 1.142" Brg O.D./2.049" Stack-up	K-1	A / D	PT1619
		4 ISR > 1.266" Brg O.D./2.512" Stack-up	K-1	A / B / C / D	PT1620
70-73	All Models	4 OSR > 1.123" Brg O.D./3.064" Stack-up	K-1	A / B / C / D	PT1617
PREVIA VAN FWD					
91-94	All Models - A/T	4 ISR > 1.142" Brg O.D./2.049" Stack-up	A-1	A / B	PT1619
PREVIA VAN AWD					
84-85	All Models	4 ISR > 1.024" Brg O.D./1.844" Stack-up	K-1	C	PT1605
SEQUOIA FWD					
01-04	All Models	4 OSR > 1.063" Brg O.D/ 3.217" Stack-up	A-1	A / B	PT521HD
		4 ISR > 1.142" Brg O.D./2.049" Stack-up	K-1	B / C	PT1619
SEQUOIA AWD					
01-04	All Models	4 OSR > 1.063" Brg O.D/ 3.217" Stack-up	K-1	A / D	PT521HD
		4 ISR > 1.142" Brg O.D./2.049" Stack-up	K-1	B / C	PT1619

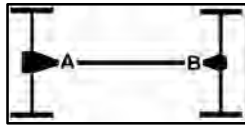

APPLICATION A-1

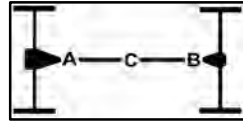

APPLICATION B-1

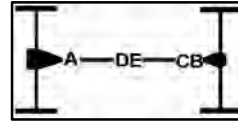

APPLICATION C-1

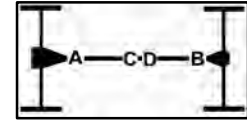

APPLICATION D-1

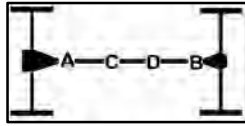

APPLICATION E-1

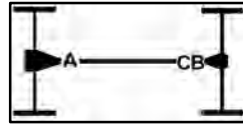

APPLICATION F-1

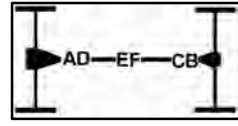

APPLICATION H-1

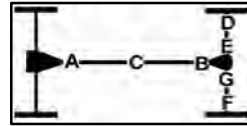

APPLICATION I-1

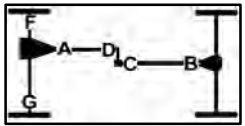

APPLICATION K-1

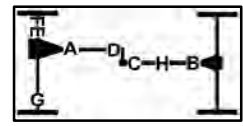

APPLICATION L-1

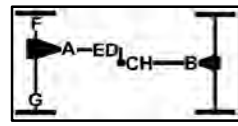

APPLICATION N-1



APPLICATION O-1

MAKE/YEARS FITMENT U-JOINT DESCRIPTION LOCATION POSITION PART NO.

TOYOTA

TOYOTA

MAKE/YEARS	FITMENT	U-JOINT DESCRIPTION	LOCATION	POSITION	PART NO.
STARLET					
81-84	All Models	4 ISR > .788" Brg O.D./1.494" Stack-up	A-1	A / B	PT1604
SUPRA					
86-93	All Models	4 ISR > 1.142" Brg O.D./2.049" Stack-up	B-1	A / B / C	PT1619
T100 PICKUP 2WD					
93-98	All Models	4 OSR > 1.063" Brg O.D/ 3.217" Stack-up	B-1	A / B / C	PT521HD
		4 ISR > 1.142" Brg O.D./2.049" Stack-up	B-1	A / B / C	PT1619
T100 PICKUP 4WD					
93-98	All Models	4 ISR > 1.142" Brg O.D./2.049" Stack-up	N-1	A / B / C / D / H	PT1619
TACOMA PICKUP 2WD					
2005	All Models	4 OSR > 1.063" Brg O.D/ 3.622" Stack-up	B-1	A / B / C	PT530
95-04	All Models	4 OSR > 1.063" Brg O.D/ 3.217" Stack-up	B-1	A / B / C	PT521HD
		4 ISR > 1.142" Brg O.D./2.049" Stack-up	B-1	A / B / C	PT1619
TACOMA PICKUP 4WD					
95-04	All Models	4 ISR > 1.142" Brg O.D./2.049" Stack-up	N-1	B / C / D / E	PT1619
TUNDRA PICKUP 2WD					
00-04	All Models	4 OSR > 1.063" Brg O.D/ 3.217" Stack-up	B-1	A / B / C	PT521HD
TUNDRA PICKUP 4WD					
00-07	All Models	4 OSR > 1.063" Brg O.D/ 3.217" Stack-up	K-1	D / E	PT521HD
		4 ISR > 1.142" Brg O.D./2.049" Stack-up	K-1	B / C	PT1619

CONVERSION KIT LISTING BY PART NUMBER

PTC #	OE Series	Brg Type	Bearing Size	PTC #
PT 220	1550 Spicer to 6C / 62N / 6CL BW	4 OSR 4 LWT	1.375" 1.687" Bolt Holes	PT555 to PT6100
PT 221	1550 Spicer to 6BL BW	4 OSR 4 HWD	1.375" 1.687" Bolt Holes	PT555 to PT6106
PT 248	1.75R BW to 1210 Spicer	4 ISR 4 OSR	1.000" 1.063"	PT1750G to PT315
PT 320	7260 Detroit to PT675	4 ISR 2 ISR & 2 OSR	1.078" 1.125	PT266 to PT675
PT 324	1810 Spicer to 9C BW	4 BKPLT 4 HWD	1.937" 2.812" Bolt Holes	PT281 to PT9031
PT 326	1880 Spicer to 9C BW	4 BKPLT 4 HWD	2.185" 2.812" Bolt Holes	PT308 to PT9031
PT 328	1550 Spicer to 58WB Rockwell	4 OSR 4 HWD	1.375" 1.937" Bolt Holes	PT555 to PT58WB
PT 329	1550 Spicer to 58WB1 Rockwell	4 OSR 4 LWT	1.375" 1.937" Bolt Holes	PT555 to PT58WB1
PT 331	1650 Spicer to 7CL BW	4 OSR 4 LWT	1.625" 1.937" Bolt Holes	PT565 to PT7100
PT 345	1410 Spicer to 4BL BW	4 OSR 4 HWD	1.188" 1.437" Bolt Holes	PT560 to PT4113
PT 348	1480 Spicer to 5C / 5CL BW	4 OSR 4LWT	1.375" 1.687" Bolt Holes	PT588 to PT5100
PT 352	3R BW to P55 Clvd / 1330 Spicer	4 ISR 2 ISR & 2 OSR	1.125" 1.125"	PT3105 to PT1204
PT 353	1280 / 1310 Spicer to 7260 Detroit	4 OSR 4 ISR	1.063" 1.078"	PT521HD to PT266
PT 354	7290 Detroit to 1280 / 1310 Spicer	4 ISR 4 OSR	1.125" 1.063"	PT231 to PT521HD
PT 355	7290 Detroit to 3R BW	4 ISR 4 ISR	1.125" 1.125"	PT231 to PT3105
PT 356	1280 / 1310 Spicer to 3R BW	4 OSR 4 ISR	1.063" 1.125"	PT521HD to PT3105

CONVERSION KIT LISTING BY PART NUMBER

PTC #	OE Series	Brg Type	Bearing Size	PTC #
PT 357	5380 Detroit to 1410 Spicer	4 ISR 4 OSR	1.231" 1.188"	PT373 to PT560
PT 358	1280 / 1310 Spicer to 1350 Spicer	4 OSR 4 OSR	1.063" 1.188"	PT521HD to PT578
PT 360	7290 Detroit to 7260 Detroit	4 ISR 4 ISR	1.125" 1.078"	PT231 to PT266
PT 362	7290 Detroit to P55 Clvd / 1330 Spicer	4 ISR 4 ISR & 4 OSR	1.125" 1.063"	PT231 to PT1203
PT 366	3R BW to 1350 Spicer	4 I 4 OSR	1.125" 1.188"	PT3105 to PT578
PT 370	1280 / 1310 Spicer to 3C BW	4 OSR 4 LWT	1.063" 1.437" Bolt Holes	PT521HD to PT3152
PT 402	1350 Spicer to P55 Clvd / 1330 Spicer	4 OSR 4 ISR & 4 OSR	1.188" 1.063"	PT578 to PT1203
PT 445	1310 Spicer to 1280 / 1310 Spicer	4 ISR 4 OSR	1.063" 1.063"	PT350 to PT521HD
PT 455	1310WJ Spicer to 1280 / 1310 Spicer	4 ISR 4 OSR	1.063" 1.063"	PT260 to PT521HD
PT 457	7260 Detroit to P55 Clvd / 1330 Spicer	4 ISR 4 ISR & 4 OSR	1.078" 1.063"	PT266 to PT1203
PT 459	1350 Spicer to P55 Clvd / 1330 Spicer	4 OSR 2 ISR & 2 OSR	1.188" 1.125"	PT578 to PT1204
PT 534	1280 / 1310 Spicer to P55 Clvd / 1330 Spicer	4 OSR 4 ISR & 4 OSR	1.063" 1.063"	PT521HD to PT1203
PT 675	P55 Clvd / 1330 Spicer to 1 1/8" Pinion Yoke	4 ISR & 4 OSR	1.063" 1.125"	PT1203
PT 1202	1280 / 1310 Spicer to 1330 Spicer	4 OSR 4 ISR	1.063" 1.063"	PT521HD to PT1203
PT 2126	2R BW to 2C BW	4 ISR 4 LWT	1.000" 1.312" Bolt Holes	PT2127 to PT2103
PT 2140	2R BW to 1280 / 1310 Spicer	4 ISR 4 OSR	1.000" 1.063"	PT2127 to PT521HD

CONVERSION KIT LISTING BY PART NUMBER

PTC #	OE Series	Brg Type	Bearing Size	PTC #
PT 2173	2R BW to PT675	4 ISR 2 ISR & 2 OSR	1.000" 1.125"	PT2127 to PT675
PT 2530	2.5R BW to 1280 /1310 Spicer	4 ISR 4 OSR	1.125" 1.063"	PT2500 to PT521HD
PT 3188	3R / 3C BW to P55 Clvld/1330 Spicer	4 ISR 4 ISR & 4 OSR	1.125" 1.063"	PT3105 to PT1203
PT 4140	4BL BW to 4C BW	4 HWD 4 LWT	1.437" Bolt Holes 1.437" Bolt Holes	PT4113 to PT4100
PT 5101	5C BW to 5C BW	4 LWD 4 LWT	1.687" Bolt Holes 1.687" Bolt Holes	PT5105 to PT5100
PT 5102	5C BW to 5BL BW	4 HWD 4 LWT	1.687" Bolt Holes 1.687" Bolt Holes	PT5108 to PT5100
PT 5110	5C BW to 5R BW	4 LWD 4 ISR	1.687" Bolt Holes 1.313"	PT5105 to PT5109
PT 5111	5R BW to 5BL BW	4 ISR 4 HWD	1.313" 1.687" Bolt Holes	PT5109 to PT5108
PT 6102	6BL BW / 62N Rock to 6C BW / 62N Rock	4 HWD 4 LWT	1.687" Bolt Holes 1.687" Bolt Holes	PT6106 to PT6100
PT 8201	8C BW to 82N Rockwell	4 LWD 4 LWT	1.937" Bolt Holes 1.937" Bolt Holes	PT8203 to PT8200
PT 8202	8C BW to 82N Rockwell	4 HWD 4 LWT	1.937" Bolt Holes 1.937" Bolt Holes	PT8105 to PT8200
PT 9017	1820 Spicer / TD J310 to 9C BW / 92N Rck	4 HWD 4 LWT	2.812" Bolt Holes 2.812" Bolt Holes	PT9031 to PT9014
PT CP58WB2	58WB Rock/6.5C BW to 58WB Rock/6.5C BW	4 HWD 4 LWT	1.937" Bolt Holes 1.937" Bolt Holes	PT58WB to PT58WB1

UNIVERSAL JOINT OE SERIES CHARTS

(PLEASE SEE UNIVERSAL JOINT IDENTIFICATION SECTION FOR SPECIFICATIONS AND DIMENSIONS.)

BORG-WARNER (Mechanics) SERIES

SERIES	PTC PART #	BEARING TYPE
1.5R	PT1501	4 ISR Rounds
1.75R	PT1750G	4 ISR Rounds
2C	PT2110	4 LWT
2C	PT2117	4 LWD
2C	PT2116	2 LWD & 2 LWT
2R	PT2127	4 ISR Rounds
2R	PT2173	4 ISR Rounds
2.5R	PT2500	4 ISR Rounds
3C	PT3152	4 LWT
3R	PT3105	4 ISR Rounds
4BL	PT4113	4 HWD
4C	PT4100	4 LWT
4C	PT4101	2 LWD & 2 LWT
5BL	PT5108	4 HWD

SERIES	PTC PART #	BEARING TYPE
5C	PT5100	4 LWT
5C	PT5101	2 LWD & 2 LWT
6BL	PT6106	4 HWD
6C	PT6100	4 LWT
6C	PT6101	2 LWD & 2 LWT
7BL	PT7105	4 HWD
7C	PT7100	4 LWT
8BL	PT8105	4 HWD
8C	PT8200	4 LWT
8C	PT8203	4 LWD
8.5BL	PT8502	4 HWD
8.5C	PT8500	4 LWT
9.5C / 9BL	PT9031	4 HWD
9C	PT9014	4 LWT

CLEVELAND SERIES

SERIES	PTC PART #	BEARING TYPE
D56	PT588	4 OSR Rounds
P55	PT530	4 OSR Rounds
P55	PT1203	4 ISR & 4 OSR
R55	PT1205	4 ISR & 4 OSR

SERIES	PTC PART #	BEARING TYPE
O55	PT1206	4 ISR & 4 OSR
S55	PT1200	4 ISR & 4 OSR
U56	PT555	4 OSR Rounds

DETROIT (CHRYSLER) SERIES

SERIES	PTC PART #	BEARING TYPE
5380	PT373	4 ISR Rounds
7260	PT266	4 ISR Rounds

SERIES	PTC PART #	BEARING TYPE
7260	PT233	4 ISR Rounds
7290	PT231	4 ISR Rounds

ROCKWELL SERIES

SERIES	PTC PART #	BEARING TYPE
131N	PT1200	4 ISR & 4 OSR
133N	PT1203	4 ISR & 4 OSR
133N	PT530	4 OSR Rounds
141N	PT1206	4 ISR & 4 OSR
16N	PT279	4 Backplate
17N	PT280	4 Backplate
18N	PT281	4 Backplate
35N	PT35N	4 OSR Rounds
44R	PT44N	4 ISR Rounds
55N	PT55N	4 OSR Rounds
58WB	PT58WB	4 HWD
58WB	PT58WB1	4 LWT
58WB	PT58WB2	2 HWD & 2 LWT
58WB-1	PT58WB1	4 LWT
58WB-2	PT58WB2	2 HWD & 2 LWT
5N	PT515	4 Backplate

SERIES	PTC PART #	BEARING TYPE
62N	PT6100	4 LWT
62N	PT6102	2 HWD & 2 LWT
62N	PT6106	4 HWD
72N	PT7100	4 LWT
72N	PT7105	4 HWD
82N	PT8105	4 HWD
82N	PT8200	4 LWT
82N	PT8202	2 HWD & 2 LWT
85WB	PT8500	4 LWT
85WB	PT8502	4 HWD
92N	PT9014	4 LWT
92N	PT9031	4 HWD
L10	PT10N	4 OSR Rounds
L12N	PT12N	4 ISR Rounds
L6N / L6S	PT6N8	4 ISR Rounds

UNIVERSAL JOINT OE SERIES CHARTS

(PLEASE SEE UNIVERSAL JOINT IDENTIFICATION SECTION FOR SPECIFICATIONS AND DIMENSIONS.)

SPICER SERIES

SERIES	PTC PART #	BEARING TYPE
1000	PT570	4 ISR Rounds
1000	PT510	4 ISR Rounds
1000SG	PT503	4 ISR Rounds
1100	PT514	4 OSR Rounds
1100	PT501	4 OSR Rounds
1110	PT1750G	4 ISR Rounds
1140	PT12N	4 ISR Rounds
1210	PT456	4 ISR & 4 OSR
1210	PT315	4 OSR Rounds
1240	PT14N	4 OSR Rounds
1260	PT521HD	4 OSR Rounds
1260	PT521HDU	4 OSR Rounds
1270	PT521HD	4 OSR Rounds
1270	PT521HDU	4 OSR Rounds
1280	PT521HD	4 OSR Rounds
1280	PT521HDU	4 OSR Rounds

SERIES	PTC PART #	BEARING TYPE
1300	PT504	4 OSR Rounds
1310	PT521HD	4 OSR Rounds
1310	PT521HDU	4 OSR Rounds
1310	PT350	4 ISR Rounds
1310HDWJ	PT297	4 ISR Rounds
1310WJ	PT260	4 ISR Rounds
1330	PT530	4 OSR Rounds
1330	PT1203	4 ISR & 4 ISR
1330	PT3188	2 ISR & 2 OSR
1330	PT1204	2 ISR & 2 OSR
1340	PT35N	4 OSR Rounds
1350	PT578	4 OSR Rounds
1410	PT1206	4 ISR Rounds
1410	PT560	4 OSR Rounds
1440	PT44N	4 ISR Rounds
1480	PT588	4 OSR Rounds

SPICER (DANA) SERIES

SERIES	PTC PART #	BEARING TYPE
1480WJ	PT332	4 ISR Rounds
1500	PT515	4 Backplate
1510	PT22GB	4 OSR Rounds
1550	PT555	4 OSR Rounds
1600	PT279	4 Backplate
1610	PT279	4 Backplate
1610	PT279HR	2 BP & 2 Rnds
1610	PT279HRK	2 BP & 2 Rnds
1650	PT565	4 OSR Rounds
1700	PT280	4 Backplate
1710	PT280	4 Backplate

SERIES	PTC PART #	BEARING TYPE
1710	PT280HR	2 BP & 2 Rnds
1710	PT280HRK	2 BP & 2 Rnds
1760	PT407	4 Backplate
1760	PT407HR	2 BP & 2 Rnds
1760	PT407HRK	2 BP & 2 Rnds
1800	PT524	4 Backplate
1810	PT281	4 Backplate
1810	PT281HR	2 BP & 2 Rnds
1810	PT281HRK	2 BP & 2 Rnds
1820	PT9031	4 HWD
1880	PT308	4 Backplate

SPICER (SPL) SERIES

SERIES	PTC PART #	BEARING TYPE
SPL90	PTSPL90	4 OSR Rounds

SERIES	PTC PART #	BEARING TYPE
SPL170	PTSPL170	4 Spring Tab
SPL250	PTSPL250	4 Spring Tab

TWIN DISC SERIES

SERIES	PTC PART #	BEARING TYPE
J230	PT8502	4 HWD

SERIES	PTC PART #	BEARING TYPE
J310	PT9031	4 HWD

UNIVERSAL JOINT U-BOLTS, BEARING CLAMPS & HARDWARE



U-BOLT KITS

PART #	CTR BOLT DIMEN.	U-BOLT LENGTH	BOLT SIZE	BRG CAP DIMEN.	USE WITH U-JOINT
PT102UJ	1.969"	1.969"	5/16"-24	1.063" (1-1/16")	PT248 PT534 PT521HD PT530 PT2530
PT103UJ	1.656"	2.188"	3/8"-24	1.188" (1-3/16")	PT560 PT1206 PT578
PT104UJ	1.375"	1.875"	1/4"-28	1.000"	PT1750G
PT105UJ	1.594"	1.971"	5/16"-18	1.125" (1-1/8")	PT352 PT1204 PT675 PT2173
PT109UJ	1.906"	2.406"	7/16"-20	1.375" (1-3/8")	PT555 PT588



BEARING CLAMP KITS

PART #	CTR BOLT DIMEN.	BOLT SIZE	BRG CAP DIMEN.	USE WITH U-JOINT
PT106UJ	1.50"	1/4-28 X 5/8"	1.078" (1-5/64")	PT233 PT353 PT266 PT457
PT107UJ	1.59"	6"-24 X 1-5/16"	1.063" (1-1/16")	PT350 PT530 PT521HD
PT107AUJ	1.59"	1/4-28 X 5/8"	1.063" (1-1/16")	PT315 PT521HD
PT108UJ	1.81"	6"-24 X 1-5/16"	1.125" (1-1/8")	PT356 PT3188 PT3105
PT110UJ	1.81"	16"-24 X 3/4"	1.188" (1-3/16")	PT560 PT578
PT111UJ	2.50"	7/8"-24 X 3/4"	1.598"	PT279HR
PT112UJ	2.81"	1/2"-20 X 1"	1.938" (1-15/16")	PT280HR PT407HR PT281HR
PT492-10UJ	1.66"	6"-24 X 1-5/16"	1.188" (1-3/16")	PT560 PT578

LOCK STRAPS & CAP SCREWS

PART #	DESCRIPTION
PTM703	LOCKSTRAPS FOR A PT280
PTMB279	5/16"-24 X 39/94" CAP SCREWS FOR PT279
PTMB280	3/8"-24 X 1/2" CAP SCREWS FOR PT280

4 OUTSIDE SNAP RING BEARING STYLE KITS

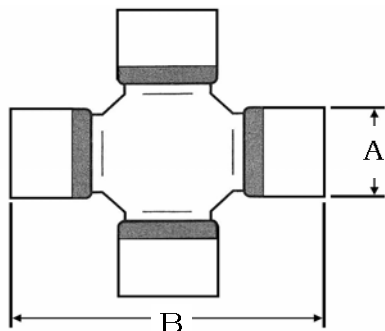

Measuring Directions:

1. Measure the diameter of all the bearing caps (A). Locate the correct measurements in the Bearing Diameter column.
2. Measure the stack-up dimension (B) and locate the proper dimension in the stack-up column.
3. Locate the different type of zerk fittings in the zerk type column.

ISR: Inside Snap Ring OSR: Outside Snap Ring

(Dimen. A) (Dimen. B)

PTC #	Bearing Diameter	Stack-up	Zerk Type	Hardware	OE Series
PT1604	0.788	2.236	(1) Bearing end	(4) ISR (4) OSR	Datsun / Toyota
PT10N	0.875	2.437	(1) Bearing end	(4) OSR	Rockwell L10
PT514	0.938	2.407	(1) Btwn Trunnions	(4) OSR	Spicer 1100
PT514CL	0.938	2.407	(1) Cntr of Cross	(4) OSR	Spicer 1100
PT501	0.938	2.407	Non-lube	(4) OSR	Spicer 1100
PT1601	0.985	2.498	Non-lube	(4) OSR	Dodge
PT1625	0.985	3.030	(1) Btwn Trunnions	(4) OSR	Dodge
PT408	1.024	2.756	(1) Bearing end	(4) OSR	Suzuki
PT315	1.063	2.437	(1) Bearing end	(4) ISR (4) OSR	Spicer 1210
PT456	1.063	2.437	Non-lube	(4) ISR (4) OSR	Spicer 1210-wj
PT504	1.063	2.931	(1) Btwn Trunnions	(4) OSR	Spicer 1300
PT521HD	1.063	3.217	(1) Btwn Trunnions	(4) OSR	Spicer 1280/1280sg/1310
PT521HDP	1.063	3.217	Non-lube	(4) OSR	Spicer 1280/1280sg/1310
PT521HDSJ	1.063	3.217	(1) Btwn Trunnions	(4) OSR	TUFF-JOINT
PT521HDU	1.063	3.217	(1) Btwn Trunnions	(4) OSR (2) PT102UJ	Spicer 1280/1280sg/1310
PT495	1.063	3.217	(1) Bearing end	(4) OSR	Spicer 1310-cv
PT1200	1.063	3.217	(1) Btwn Trunnions	(4) ISR (4) OSR	Cleveland S55
PT1200SJ	1.063	3.217	(1) Btwn Trunnions	(4) ISR (4) OSR	TUFF-JOINT
PT1202	1.063	3.217	(1) Btwn Trunnions	(2) ISR (4) OSR	Spicer 1310 to Spicer 1330
	1.063	3.622			PT521HD to PT1203
PT530	1.063	3.622	(1) Btwn Trunnions	(4) OSR	Cleveland P55 / Spicer 1330
PT530SJ	1.063	3.622	(1) Btwn Trunnions	(4) OSR	TUFF-JOINT
PT1203	1.063	3.622	(1) Btwn Trunnions	(4) ISR (4) OSR	Cleveland P55 / Spicer 1330
PT1203SJ	1.063	3.622	(1) Btwn Trunnions	(4) ISR (4) OSR	TUFF-JOINT
PT534	1.063	3.622	(1) Btwn Trunnions	(4) OSR	PT521HD to PT1203
	1.063	3.217			Spicer 1310 to Spicer 1330
PT402	1.063	3.622	(1) Btwn Trunnions	(4) OSR	PT578 to PT530
	1.188	3.622			Spicer 1350 to Clev P55
PT1207	1.066	3.622	Non-lube	(4) OSR	1330XC
PT353	1.078		(1) Btwn Trunnions	(4) ISR (4) OSR	PT521HD to PT266
	1.063	3.217			Spicer 1310 to Detroit 7260
PT1617	1.123	3.064	(1) Cntr of Cross	(4) OSR	Toyota
PT14N	1.125	2.626	(1) Cntr of Cross	(4) OSR	Rck 14N / Spicer 1240
PT459	1.125	3.622	(1) Btwn Trunnions	(4) OSR	PT578 to PT1204
	1.188	3.622			Spicer 1330 to Clev P55/Spicer 1330
PT577	1.188	3.612	Non-lube	(4) OSR	AAM 1355
PT358	1.188	3.622	Non-lube	(4) OSR	PT521HD to PT578
	1.063	3.217			Spicer 1310 to Spicer 1350
PT498	1.188	3.622	(4) Bearing end	(4) OSR	Spicer 1350

4 OUTSIDE SNAP RING BEARING STYLE KITS

(Dimen. A) (Dimen. B)

PTC #	Bearing Diameter	Stack-up	Zerk Type	Hardware	OE Series
PT578	1.188	3.622	(1) Btwn Trunnions	(4) OSR	Spicer 1350
PT578SJ	1.188	3.622	(1) Btwn Trunnions	(4) OSR	TUFF-JOINT
PT578U	1.188	3.622	(1) Btwn Trunnions	(4) OSR (2) PT110UJ	Spicer 1350
PT1205	1.188	3.622	(1) Btwn Trunnions	(4) ISR (4) OSR	Cleveland R55 / Rockwell 135N
PT1206	1.188	4.182	(1) Btwn Trunnions	(4) ISR (4) OSR	Cleveland O55
PT560	1.188	4.182	(1) Btwn Trunnions	(4) OSR	Spicer 1410
PT560U	1.188	4.182	(1) Btwn Trunnions	(4) OSR (2) PT110UJ	Spicer 1410
PT35N	1.250	3.205	(1) Cntr of Cross	(4) OSR	Rck 35N / Spicer 1340
PT1637	1.297	3.656	(1) Cntr of Cross	(4) OSR	
PT587	1.375	4.178	Non-lube	(4) OSR	AAM 1485
PT588	1.375	4.182	(1) Btwn Trunnions	(4) OSR	Spicer 1480
PT555	1.375	4.966	(1) Btwn Trunnions	(4) OSR	Spicer 555
PT55N	1.532	4.310	(1) Cntr of Cross	(4) OSR	Rockwell 55N
PTGB22	1.562	4.562	(1) Btwn Trunnions	(4) OSR	Spicer 1510
PT462	1.575	4.527	(1) Btwn Trunnions	(4) OSR	Hino, Isuzu & GM
PTSPL90	1.625	5.141	(1) Cntr of Cross	N/A	Spicer SPL90
PTSPL170	55mm	164mm	(1) Cntr of Cross	N/A	Spicer SPL170
PTSPL250	60mm	163mm	(1) Cntr of Cross	N/A	Spicer SPL250
PT565	1.625	5.599	(1) Btwn Trunnions	(4) OSR	Spicer 1650

4 INSIDE SNAP RING BEARING STYLE KITS

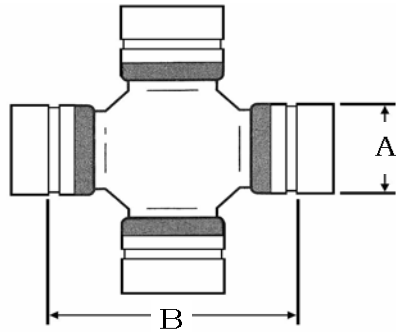

Measuring Directions:

1. Measure the diameter of all the bearing caps. Locate the correct measurements in the Bearing Diameter column.
2. Measure over the opposite snap rings (Dimen. B) to find the Over ISR Stack-up dimension.
3. Locate the different type of zerk fittings in the zerk type column.

ISR: Inside Snap Ring
OSR: Outside Snap Ring

PTC #	(Dimen. A) Bearing Diameter	(Dimen. B) Over ISR Stack-up	Zerk Type	Hardware	OE Series
PT1604	0.788	1.494	(1) Bearing end	(4) ISR (4) OSR	Datsun / Toyota / Nissan
PT1623	0.891	1.484	(1) Btwn Trunnions	(4) ISR	Mazda
PT503	0.937	1.474	(1) Cntr of Cross	(4) ISR	
PT510	0.937	1.474	(1) Cntr of Cross	(4) ISR	Neapco O675
PT570	0.937	1.494	(1) Cntr of Cross	(4) ISR	Spicer 1000
PT1501	0.968	1.689	(1) Cntr of Cross	(4) ISR	BW1.5R
PT6N8	0.969	1.445	(1) Cntr of Cross	(4) ISR	Rck L6N
PT576	0.969	1.474	(1) Cntr of Cross	(4) ISR	
	0.937	1.445			
PT1606	0.985	1.717	(1) Bearing end	(4) ISR	Mazda
PT1603	0.985	1.731	(1) Bearing end	(4) ISR	Nissan / Datsun / Subaru
PT1750G	1.000	1.714	(1) Bearing end	(4) ISR	Spicer 1100 / BW 1.75R
PT2127	1.000	2.338	Non-Lube	(4) ISR	BW2R
PT1605	1.024	1.844	(1) Bearing end	(4) ISR	Toyota
PT1616	1.024	2.197	Non-Lube	(4) ISR	Toyota
PT1622	1.044	1.986	(1) Bearing end	(4) ISR	Mazda
PT315	1.063	1.635	(1) Bearing end	(4) ISR (4) OSR	Spicer 1210
PT315SJ	1.063	1.635	(1) Bearing end	(4) ISR (4) OSR	TUFF-JOINT
PT456	1.063	1.635	Non-Lube	(4) ISR (4) OSR	Spicer 1210 wj
PT456SJ	1.063	1.635	Non-Lube	(4) ISR (4) OSR	TUFF-JOINT
PT12N	1.063	1.816	(1) Cntr of Cross	(4) ISR	Spicer 1140 / Rck L12N
PT446	1.063	1.930	Non-Lube	(4) ISR	Nissan
PT260	1.063	2.183	Non-Lube	(4) ISR	Spicer 1310 wj
PT260SJ	1.063	2.183	Non-Lube	(4) ISR	TUFF-JOINT
PT496	1.063	2.183	(1) Bearing end	(4) ISR	Spicer 1310 wj
PT350	1.063	2.341	(1) Btwn Trunnions	(4) ISR	Spicer 1310
PT1200	1.063	2.362	(1) Btwn Trunnions	(4) ISR (4) OSR	Cleveland S55
PT1200SJ	1.063	2.362	(1) Btwn Trunnions	(4) ISR (4) OSR	TUFF-JOINT
PT1203	1.063	2.767	(1) Btwn Trunnions	(4) ISR (4) OSR	Cleveland P55 / Spicer 1330
PT1203SJ	1.063	2.767	(1) Btwn Trunnions	(4) ISR (4) OSR	TUFF-JOINT
PT233	1.078	2.121	(1) Bearing end	(4) ISR	Detroit 7260
PT233SJ	1.078	2.121	(1) Bearing end	(4) ISR	TUFF-JOINT
PT266	1.078	2.121	(1) Btwn Trunnions	(4) ISR	Detroit 7260
PT353	1.078	2.121	(1) Btwn Trunnions	(4) ISR (4) OSR	PT521HD to PT266
	1.063	2.362			Spicer 1310 to Detroit 7260
PT1602	1.102	2.205	(1) Btwn Trunnions	(4) ISR	Nissan / Datsun / Subaru
PT1610	1.102	2.323	(1) Btwn Trunnions	(4) ISR	Mazda / Ford Courier
PT2173	1.125	2.338	(1) Btwn Trunnions	(4) ISR	BW2R
	1.000	2.338			

4 INSIDE SNAP RING BEARING STYLE KITS

PTC #	(Dimen. A)	(Dimen. B)	Zerk Type	Hardware	OE Series
	Bearing Diameter	Over ISR Stack-up			
PT356	1.125	2.555	(1) Btwn Trunnions	(4) ISR (2) OSR	PT521HD to PT3105 Spicer 1310 to BW3R
	1.063	2.362			
PT231	1.125	2.619	(1) Btwn Trunnions	(4) ISR	Spicer 7290
PT360	1.125	2.619	(1) Btwn Trunnions	(4) ISR	PT231 to PT266 Detroit 7290 to Detroit 7260
	1.078	2.121			
PT355	1.125	2.619	(1) Btwn Trunnions	(4) ISR	Detroit 7290 to BW3R PT231 to PT3105
	1.125	2.555			
PT2500	1.125	2.118	Non-Lube	(4) ISR	BW2.5R
PT3105	1.125	2.555	(1) Btwn Trunnions	(4) ISR	BW3R
PT3105SJ	1.125	2.555	(1) Btwn Trunnions	(4) ISR	TUFF-JOINT
PT1619	1.142	2.049	Non-Lube	(4) ISR	Toyota
PT1619SJ	1.142	2.049	Non-Lube	(4) ISR	TUFF-JOINT
PT1621	1.142	2.089	(1) Btwn Trunnions	(4) ISR	Isuzu
PT411	1.142	2.835	(1) Bearing end	(4) ISR	Isuzu
PT450	1.181	2.290	(1) Btwn Trunnions	(4) ISR	Mitsubishi
PT497	1.188	2.187	(1) Bearing end	(4) ISR	Spicer 1310 wj
PT497SJ	1.188	2.187	(1) Bearing end	(4) ISR	TUFF-JOINT
PT297	1.188	2.187	Non-Lube	(4) ISR	Spicer 1310 wj
PT1205	1.188	2.555	(1) Btwn Trunnions	(4) ISR (4) OSR	Cleveland R55 / Rockwell 135N
PT1206	1.188	3.118	(1) Btwn Trunnions	(4) ISR (4) OSR	Cleveland O55
PT373	1.231	2.997	(1) Btwn Trunnions	(4) ISR	Detroit 5380
PT1620	1.266	2.512	Non-Lube	(4) ISR	Toyota
PT44N	1.313	2.793	(1) Cntr of Cross	(4) ISR	Rockwell 44N
PT464	1.375	2.918	(1) Btwn Trunnions	(4) ISR	AA 1485 wj
PT332	1.375	2.995	Non-Lube	(4) ISR	Spicer 1480 wj
PT424	1.375	3.777	(1) Btwn Trunnions	(4) ISR	Spicer 1550 wj

2 INSIDE & 2 OUTSIDE SNAP RING BEARING STYLE KITS

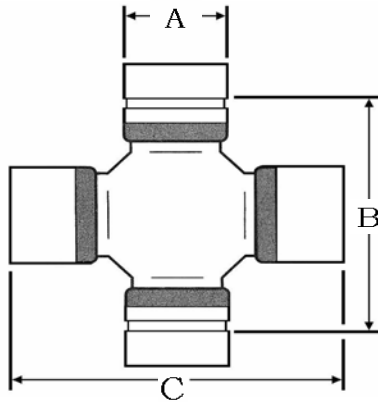

Measuring Directions:

1. Measure the diameter of all the bearing caps. Locate the correct measurements in the Bearing Diameter column.
2. Measure over the opposite snap rings (Dimen. B) to find the Over ISR Stack-up dimension.
3. Measure the stack-up of the plain bearings (Dimen. C) and locate the proper dimension in the stack-up column.
4. Locate the different type of zerk fittings in the zerk type column.

ISR: Inside Snap Ring
OSR: Outside Snap Ring

PTC #	(Dimen. A)	(Dimen. B)	(Dimen. C)	Zerk Type	Hardware	OE Series
	Bearing Diameter	Over ISR Stack-up	OSR Stack-up			
PT1604	0.788 ISR	1.494	2.236	(1) Bearing end	(4) ISR (4) OSR	Toyota
PT2140	1.000 ISR 1.063 OSR	2.344	3.218	(1) Btwn Trunnions	(2) ISR (2) OSR	PT2127 to PT521HD BW2R to Spicer 1280/1310
PT315	1.063 ISR	1.635	2.437	(1) Bearing end	(4) ISR (4) OSR	Spicer 1210
PT315SJ	1.063 ISR	1.635	2.437	(1) Bearing end	(4) ISR (4) OSR	TUFF-JOINT
PT456	1.063 ISR	1.635	2.437	Non-lube	(4) ISR (4) OSR	Spicer 1210 wj
PT456SJ	1.063 ISR	1.635	2.437	Non-lube	(4) ISR (4) OSR	TUFF-JOINT
PT248	1.063 ISR 1.000 OSR	1.740	2.437	(1) Cntr of Cross	(2) ISR (2) OSR	PT1750G to PT315 BW1.75R to Spicer 1210
PT455	1.063 ISR 1.063 OSR	2.188	3.218	(1) Btwn Trunnions	(2) ISR (2) OSR	PT260 to PT521HD Spicer 1310wj to 1280/1310
PT445	1.063 ISR 1.063 OSR	2.344	3.218	(1) Btwn Trunnions	(2) ISR (2) OSR	PT350 to PT521HD Spicer 1310 to 1280/1310
PT353	1.063 ISR 1.078 ISR	2.121	3.217	(1) Btwn Trunnions	(2) ISR (2) OSR	PT266 to PT521HD Detroit 7260 to Spicer 1310
PT675	1.063 ISR 1.125 OSR	2.362	3.217	(1) Btwn Trunnions	(2) ISR (2) OSR	P55/1310 to 1 1/8" pinion yoke PT1203/PT530 to PT521HD
PT1201 (USE PT675)	1.063 ISR 1.125 OSR	2.362	3.217	(1) Btwn Trunnions	(2) ISR (2) OSR	P55/1310 to 1 1/8" pinion yoke PT1203/PT530 to PT521HD
PT1200	1.063 ISR	2.362	3.217	(1) Btwn Trunnions	(4) ISR (4) OSR	Cleveland S55
PT1200SJ	1.063 ISR	2.362	3.217	(1) Btwn Trunnions	(4) ISR (4) OSR	TUFF-JOINT
PT1202	1.063 ISR 1.063 OSR	2.767	3.622 3.217	(1) Btwn Trunnions	(2) ISR (4) OSR	Spicer 1310 to Spicer 1330 PT521HD to PT1203
PT1203	1.063 ISR	2.767	3.622	(1) Btwn Trunnions	(4) ISR (4) OSR	Cleveland P55 / Spicer 1330
PT1203SJ	1.063 ISR	2.767	3.622	(1) Btwn Trunnions	(4) ISR (4) OSR	TUFF-JOINT
PT3188	1.063 ISR 1.125 OSR	2.555	3.622	(1) Btwn Trunnions	(2) ISR (2) OSR	PT3105 to PT530/PT1203 BW3R/3C to P55/133N/1330
PT1204	1.063 ISR 1.125 OSR	2.767	3.622	(1) Btwn Trunnions	(2) ISR (2) OSR	Cleveland P55 / Spicer 1330
PT1204SJ	1.063 ISR 1.125 OSR	2.767	3.622	(1) Btwn Trunnions	(2) ISR (2) OSR	TUFF-JOINT
PT457	1.078 ISR 1.063 OSR	2.125	3.622	(1) Btwn Trunnions	(2) ISR (2) OSR	Detroit 7260 to Clev P55 PT266 to PT530/PT1203
PT320	1.078 ISR 1.125 OSR	2.125	3.218	(1) Btwn Trunnions	(2) ISR (2) OSR	PT266 to PT675/PT1201 Detroit 7260 to PT675
PT2530	1.125 ISR 1.063 OSR	2.125	3.218	(1) Btwn Trunnions	(2) ISR (2) OSR	BW2.5R to Spicer 1280/1310 PT2500 to PT521HD

2 INSIDE & 2 OUTSIDE SNAP RING BEARING STYLE KITS

PTC #	(Dimen. A)	(Dimen. B)	(Dimen. C)	Zerk Type	Hardware	OE Series
	Bearing Diameter	Over ISR Stack-up	OSR Stack-up			
PT354	1.125 ISR 1.063 OSR	2.625	3.218	(1) Btwn Trunnions	(2) ISR (2) OSR	Detroit 7290 to Spicer 1280/1310 PT231 to PT521HD
PT362	1.125 ISR 1.063 OSR	2.625	3.622	(1) Btwn Trunnions	(2) ISR (2) OSR	Detroit 7290 to Clev P55 PT231 to PT530
PT356	1.125 ISR 1.063 OSR	2.555 2.362	3.217	(1) Btwn Trunnions	(4) ISR (2) OSR	PT521HD to PT3105 Spicer 1280/1310 to BW3R
PT352	1.125 ISR 1.125 OSR	2.563	3.622	(1) Btwn Trunnions	(2) ISR (2) OSR	BW3R to Clev P55/Spicer 1330 PT3105 to PT1204
PT366	1.188 ISR 1.125 OSR	2.555	3.622	(1) Btwn Trunnions	(2) ISR (2) OSR	PT3105 to PT578 BW3R to Spicer 1350
PT1205	1.188 ISR	2.555	3.622	(1) Btwn Trunnions	(4) ISR (4) OSR	Cleveland R55 / Rockwell 135N
PT1206	1.188 ISR	3.118	4.182	(1) Btwn Trunnions	(4) ISR (4) OSR	Cleveland O55
PT357	1.231 ISR 1.188 OSR	3.000	4.187	(1) Btwn Trunnions	(2) ISR (2) OSR	Detroit 5380 to Spicer 1410 PT373 to PT560

4 BACKPLATE BEARING STYLE KITS

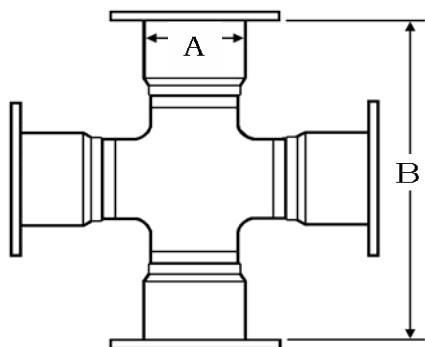

Measuring Directions:

1. Measure the diameter of all the bearing caps. Locate the correct measurements in the Bearing Diameter column.
2. Measure the distance between the opposite backplates (Dimen. B) and locate the proper dimension in the Under Backplates column.

(Dimen. A) (Dimen. B)

PTC #	Bearing Diameter	Under Backplates	Zerk Type	Hardware	OE Series
PT515	1.562	4.562	(1) Btwn Trunnions	(8) Bolts (4) Lockstraps	Spicer 1500
PT279	1.875	5.310	(2) Btwn Trunnions	(8) Bolts (4) Lockstraps	Spicer 1610/Rck 16N
PT280	1.937	6.091	(2) Btwn Trunnions	(8) Bolts (4) Lockstraps	Spicer 1710/Rck 17N
PT407	1.937	7.000	(2) Btwn Trunnions	(8) Bolts (4) Lockstraps	Spicer 1760
PT281	1.937	7.553	(2) Btwn Trunnions	(8) Bolts (4) Lockstraps	Spicer 1810/Rck 18N
PT308	2.185	8.093	(2) Btwn Trunnions	(8) Bolts (4) Lockstraps	Spicer 1880
PT524	2.321	6.592	(2) Btwn Trunnions	(8) Bolts (4) Lockstraps	Spicer 1800

2 OUTSIDE SNAP RING & 2 BACKPLATE BEARING STYLE KITS

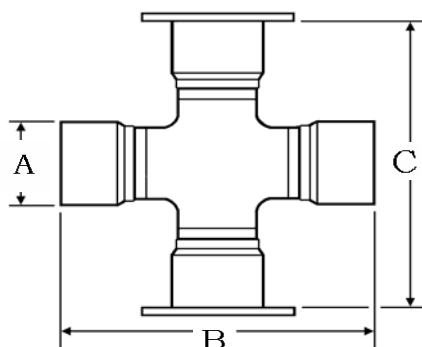

Measuring Directions:

1. Measure the diameter of all the bearing caps. Locate the correct measurements in the Bearing Diameter column.
2. Measure the distance between the opposite backplates (Dimen. B) and locate the proper dimension in the Under Backplates column.
2. Measure the stack-up dimension (B) and locate the proper dimension in the stack-up column.

(Dimen. A) (Dimen. B) (Dimen. C)

PTC #	Bearing Diameter	OSR Stack-up	Under Backplates	Hardware	OE Series
PT279HR	1.875	5.310	5.310	(4) Bolts (2) Lockstraps	Spicer 1610
PT279HRK	1.875	5.310	5.310	(8) Bolts (2) Lockstraps (2) PT111UJ Brg clamps	Spicer 1610
PT280HR	1.937	6.185	6.091	(4) Bolts (2) Lockstraps	Spicer 1710
PT280HRK	1.937	6.185	6.091	(8) Bolts (2) Lockstraps (2) PT112UJ Brg clamps	Spicer 1710
PT407HR	1.937	7.092	7.000	(4) Bolts (2) Lockstraps	Spicer 1760
PT407HRK	1.937	7.092	7.000	(8) Bolts (2) Lockstraps (2) PT112UJ Brg clamps	Spicer 1760
PT281HR	1.937	7.640	7.553	(4) Bolts (2) Lockstraps	Spicer 1810
PT281HRK	1.937	7.640	7.553	(8) Bolts (2) Lockstraps (2) PT112UJ Brg clamps	Spicer 1810
PT381	1.999 1.937	6.164	6.091	(8) Bolts (4) Lockstraps	

BLOCK & WING BEARING STYLE KITS

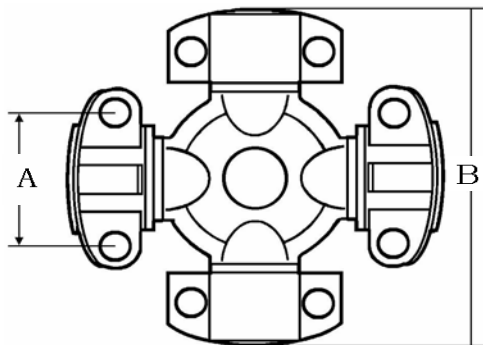

Measuring Directions:

1. Measure bolt hole to bolt hole (Dimen. A) on all of the bearing caps. Locate the correct length in the Bolt Hole Length column.
2. Measure the pilot diameter (Dimen. B) of opposite bearing caps. Locate the measurement in the Pilot Diameter column.
3. Check to see if the bolt holes are drilled through or threaded. Different types are listed in the Bearing Type column.

(Dimen. B) (Dimen. A)

Pilot Bolt Hole

PTC #	Diameter	Length	Zerk Type	Bearing Type	Hardware	OE Series
PT2110	3.122	1.312	(1) Bearing end	4 LWT	(8) Bolts (8) Washers	Mechanics 2C
PT2117	3.122	1.312	(1) Bearing end	4 LWD	(8) Bolts (8) Washers	Mechanics 2C
PT2116	3.122	1.312	(1) Bearing end	2 LWD & 2 LWT	(8) Bolts (8) Washers	Mechanics 2C
PT3152	3.559	1.437	(1) Btwn Trunnions	4 LWT	(8) Bolts (8) Washers	Mechanics 3C
PT4100	4.247	1.437	(1) Btwn Trunnions	4 LWT	(8) Bolts (8) Washers	Mechanics 4C
PT4101	4.247	1.437	(1) Btwn Trunnions	2LWT & 2LWD	(8) Bolts (8) Washers	Mechanics 4C
PT4113	4.247	1.437	(1) Btwn Trunnions	4 HWD	(8) Bolts (8) Washers	Mechanics 4C
PT4140	4.247	1.437	(1) Btwn Trunnions	2 LWT & 2 HWD	(8) Bolts (8) Washers	BW4BL to BW4C PT4113 to PT4100
PT5100	4.526	1.687	(1) Btwn Trunnions	4 LWT	(8) Bolts (4) Lockstraps	Mechanics 5C
PT5101	4.526	1.687	(1) Btwn Trunnions	2 LWD & 2 LWT	(8) Bolts (4) Washers (2) Lockstraps	Conversion kit Mechanics 5C
PT5102	4.526	1.687	(2) Btwn Trunnions	2 LWT & 2 HWD	(8) Bolts (4) Washers (2) Lockstraps	Conversion kit BW5C to BW5BL
PT5108	4.526	1.687	(1) Btwn Trunnions	4 HWD	(8) Bolts (8) Washers	Mechanics 5BL
PT58WB	5.311	1.937	(1) Btwn Trunnions	4 HWD	(8) Bolts (8) Washers	Rck 58WB/Mech. 6.5C
PT58WB1	5.311	1.937	(1) Btwn Trunnions	4 LWT	(8) Bolts (8) Washers	Rck 58WB/Mech. 6.5C
PT58WB2	5.311	1.937	(1) Btwn Trunnions	2 HWD & 2 LWT	(8) Bolts (8) Washers	Rck 58WB/Mech. 6.5C PT58WB to PT58WB1
PT6106	5.526	1.687	(1) Btwn Trunnions	4 HWD	(8) Bolts (8) Washers	Mech 6BL / Rck 62N
PT6100	5.526	1.687	(1) Btwn Trunnions	4 LWT	(8) Bolts (8) Washers (4) Lockstraps	Mech 6C / Rck 62N
PT6101	5.526	1.687	(1) Btwn Trunnions	2 LWT & 2 LWD	(8) Bolts (8) Washers (4) Lockstraps	Mech 6C / Rck 62N
PT6102	5.526	1.687	(1) Btwn Trunnions	2 HWD & 2 LWT	(8) Bolts (2) Lockstraps	6BL / 62N to 6C PT6106 to PT6100
PT6109	5.840 5.526	1.937 1.687	(1) Btwn Trunnions	2 HWD & 2 LWT	(8) Bolts (2) Lockstraps	Mech 6C to Mech 7BL PT6100 to PT7105
PT7105	5.840	1.937	(1) Btwn Trunnions	4 HWD	(8) Bolts	Mech 7BL / Rck 72N
PT7100	5.840	1.937	(1) Btwn Trunnions	4 LWT	(8) Bolts (4) Lockstraps	Mech 7C / Rck. 72N
PT7102	5.840	1.937	(1) Btwn Trunnions	2 HWD & 2 LWT	(8) Bolts (4) Washers (2) Lockstraps	Mech 7C / Rck 72N
PT8502	6.501	2.812	(1) Btwn Trunnions	4 HWD	(8) Bolts (8) Washers	8.5BL / J230 / 85WB
PT8500	6.501	2.812	(1) Btwn Trunnions	4 LWT	(8) Bolts (8) Washers	8.5BL / J230 / 85WB
PT8105	8.120	1.937	(1) Btwn Trunnions	4 HWD	(8) Bolts	Mech 8BL / Rck 82N
PT8200	8.120	1.937	(1) Btwn Trunnions	4 LWT	(8) Bolts	Mech 8C / Rck 82N
PT8201	8.120	1.937	(1) Btwn Trunnions	2 LWD & 2 LWT	(8) Bolts	8C BW to 82N Rock PT8203 to PT8200

BLOCK & WING BEARING STYLE KITS

(Dimen. B) (Dimen. A)

PTC #	Pilot Diameter	Bolt Hole Length	Zerk Type	Bearing Type	Hardware	OE Series
PT8203	8.120	1.937	(1) Btwn Trunnions	4 LWD	(8) Bolts	Mechanics 8C
PT8202	8.120	1.937	(1) Btwn Trunnions	2 HWD & 2 LWT	(8) Bolts (4) Washers (2) Lockstraps	8C BW to 82N Rock PT8105 to PT8200
PT9031	8.247	2.812	(1) Btwn Trunnions	4 HWD	(8) Bolts (4) Washers	Mech 9BL / Rck 92N
PT9014	8.247	2.812	(2) Btwn Trunnions	4 LWT	(8) Bolts	Mech 9C / Rck 92N
PT9017	8.247	2.812	(2) Btwn Trunnions	2 HWD & 2 LWT	(8) Bolts (4) Washers	1820 / J310 to 9C PT9031 to PT9014

Bearing Abbreviations:

- LWD: Low Wing Drilled
- LWT: Low Wing Threaded
- HWD: High Wing Drilled
- HWT: High Wing Threaded
- BP: Backplates
- ISR: Inside Snap Rings

⁽⁰⁾: No Lube Fitting

⁽¹⁾: One lube fitting between the trunnions

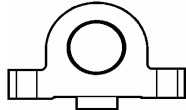

Low Wing Bearing

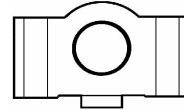

High Wing (Block) Bearing

2 OUTSIDE SNAP RING & 2 BLOCK OR WING BEARING STYLE

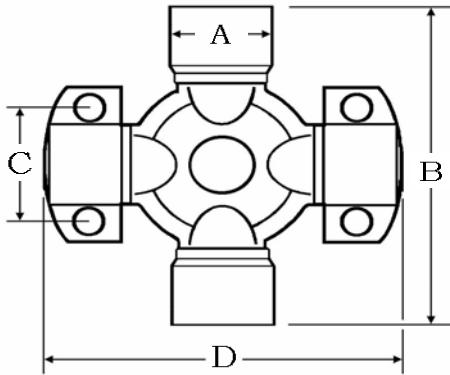

Measuring Directions:

1. Measure the diameter of the grooved bearings (Dimen. A).
2. Measure over the opposite bearing caps (Dimen. B) to find the Over OSR Stack-up dimension.
3. Measure bolt hole to bolt hole (Dimen. C) on all of the bearing caps. Locate the correct length in the Bolt Hole Length column.
4. Measure the pilot diameter (Dimen. D) of opposite bearing caps. Locate the measurement in the Pilot Diameter column.

PTC Part #	(Dimen. A) Bearing Diameter	(Dimen. B) Over ISR Stack-up	(Dimen. D) Pilot Diameter	(Dimen. C) Bolt Hole Length	Bearing Type	Hardware	OE Series
PT370⁽¹⁾	1.063	3.217	3.559	1.437	2 OSR & 2 LWT	(2) OSR (4) Bolts (4) Lockstraps	Spicer 1310 to BW3C PT521HD to PT3152
PT345⁽¹⁾	1.188	4.182	4.250	1.437	2 OSR & 2 HWD	(2) OSR (4) Bolts	Spicer 1410 to BW 4BL PT560 to PT4113
PT348⁽¹⁾	1.375	4.182	4.526	1.687	2 OSR & 2 LWT	(2) OSR (4) Bolts	Spicer 1480 to BW 5C PT588 to PT5100
PT220⁽¹⁾	1.375	4.966	5.526	1.687	2 OSR & 2 LWT	(2) OSR (4) Bolts	Spicer 1550 to BW 6C PT555 to PT6100
PT221⁽¹⁾	1.375	4.966	5.526	1.687	2 OSR & 2 HWD	(2) OSR (4) Bolts	Spicer 1550 to BW 6BL PT555 to PT6106
PT328⁽¹⁾	1.375	4.966	5.311	1.937	2 OSR & 2 HWD	(2) OSR (4) Bolts (4) Lockstraps	Spicer 1550 to 58WB PT555 to PTC58WB
PT329⁽¹⁾	1.375	4.966	5.311	1.937	2 OSR & 2 LWT	(2) OSR (4) Bolts (4) Lockstraps	Spicer 1550 to 58WB1 PT555 to PTC58WB1
PT331⁽¹⁾	1.625	5.599	5.84	1.937	2 OSR & 2 LWT	(2) OSR (4) Bolts (4) Lockstraps	Spicer 1650 to BW 7CL PT565 to PT7100

Bearing Abbreviations:

LWD: Low Wing Drilled
 LWT: Low Wing Threaded
 HWD: High Wing Drilled
 HWT: High Wing Threaded
 BP: Backplates
 ISR: Inside Snap Rings

⁽⁰⁾: No Lube Fitting

⁽¹⁾: One lube fitting between the trunnions

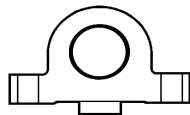

Low Wing Bearing

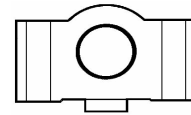

High Wing (Block) Bearing

2 BACKPLATE & 2 BLOCK OR WING BEARING STYLE KITS

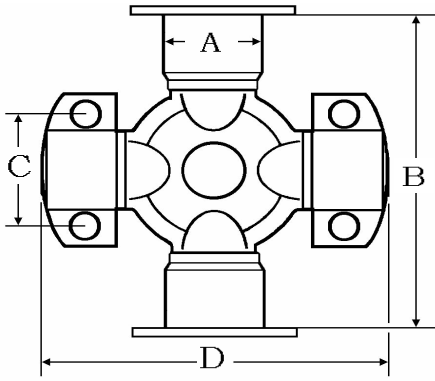

Measuring Directions:

1. Measure the diameter of the backplate bearings (Dimen. A)
2. Measure the distance under opposite backplates (Dimen. B)
Locate in Under Backplate column.
3. Measure bolt hole to bolt hole (Dimen. A) on all of the bearing caps.
Locate the correct length in the Bolt Hole Length column.
4. Measure the pilot diameter (Dimen. B) of opposite bearing caps.
Locate the measurement in the Pilot Diameter column.

PTC Part #	(Dimen. A) Bearing Diameter	(Dimen. B) Under Backplates	(Dimen. D) Pilot Diameter	(Dimen. C) Bolt Hole Length	Bearing Type	Hardware	OE Series
PT324 ⁽¹⁾	1.937	7.553	8.247	2.812	2 HWD & 2 BP	(8) Bolts (2) Lockstraps	18N/1810 to 1820/92N PT281 to PT9031
PT326 ⁽¹⁾	2.185	8.093	8.247	2.812	2 HWD & 2 BP	(8) Bolts (2) Lockstraps	PT308 to PT9031

2 INSIDE SNAP RING & 2 BLOCK OR WING BEARING STYLE KITS

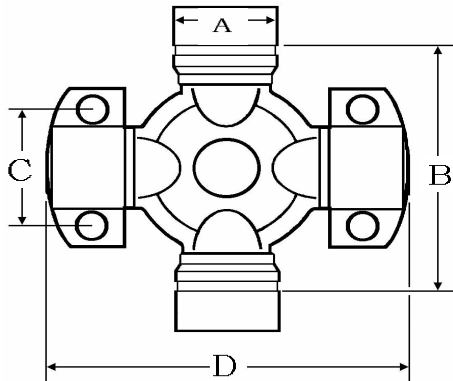

Measuring Directions:

1. Measure the diameter of the grooved bearings (Dimen. A).
2. Measure over the opposite snap rings (Dimen. B) to find the Over ISR Stack-up dimension.
3. Measure bolt hole to bolt hole (Dimen. C) on all of the bearing caps.
Locate the correct length in the Bolt Hole Length column.
4. Measure the pilot diameter (Dimen. D) of opposite bearing caps. Locate the measurement in the Pilot Diameter column.

PTC #	(Dimen. A) Bearing Diameter	(Dimen. B) Over ISR Stack-up	(Dimen. D) Pilot Diameter	(Dimen. C) Bolt Hole Length	Bearing Type	Hardware	OE Series
PT2126 ⁽⁰⁾	1.000	2.338	3.122	1.312	2 ISR & 2 LWT	(2) ISR (4) Bolts (4) Lockstraps	Mech 2R to Mech 2C PT2127 to PT2103
PT2114 ⁽⁰⁾	1.000	2.338	3.122	1.312	2 ISR & 2 LWD	(2) ISR (4) Bolts (4) Lockstraps	Mech 2R to Mech 2C PT2127 to PT2117
PT5111 ⁽¹⁾	1.313	3.308	4.526	1.687	2 ISR & 2 HWD	(2) ISR (4) Bolts (4) Lockstraps	Mech 5R to Mech 5BL PT5109 to PT5108
PT5110 ⁽¹⁾	1.313	3.308	4.526	1.687	2 ISR & 2 LWT	(2) ISR (4) Bolts (4) Lockstraps	Mech 5C to Mech 5R PT5105 to PT5109

Bearing Abbreviations:

LWD: Low Wing Drilled
LWT: Low Wing Threaded
HWD: High Wing Drilled
HWT: High Wing Threaded
BP: Backplates
ISR: Inside Snap Rings

⁽⁰⁾: No Lube Fitting

⁽¹⁾: One lube fitting between the trunnions

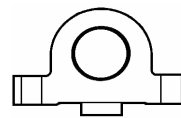

Low Wing Bearing

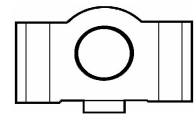

High Wing (Block) Bearing

APPLICATION LISTING BY PART NUMBER

PART NO. MAKE MODEL

PT102UJ	U-BOLT KIT	FOR 1.063" BEARING CAPS. USE WITH PT521HD, PT530
PT103UJ	U-BOLT KIT	FOR 1.188" BEARING CAPS. USE WITH PT560, PT1206, PT578
PT104UJ	U-BOLT KIT	FOR 1.000" BEARING CAPS. USE WITH PT1750G
PT105UJ	U-BOLT KIT	FOR 1.125" BEARING CAPS. USE WITH PT1204, PT675
PT106UJ	BRG CLAMP KIT	FOR 1.078" BEARING CAPS. USE WITH PT233, PT266
PT107UJ	BRG CLAMP KIT	FOR 1.063" BEARING CAPS. USE WITH PT350, PT530, PT521HD
PT107AUJ	BRG CLAMP KIT	FOR 1.063" BEARING CAPS. USE WITH PT315, PT521HD
PT108UJ	BRG CLAMP KIT	FOR 1.125" BEARING CAPS. USE WITH PT356, PT3188, PT3105
PT109UJ	U-BOLT KIT	FOR 1.375" BEARING CAPS. USE WITH PT555, PT588
PT110UJ	BRG CLAMP KIT	FOR 1.188" BEARING CAPS. USE WITH PT560, PT578
PT111UJ	BRG CLAMP KIT	FOR 1.598" BEARING CAPS. USE WITH PT279HR
PT112UJ	BRG CLAMP KIT	FOR 1.938" BEARING CAPS. USE WITH PT280HR, PT281HR, PT407HR
PT1200		4 INSIDE/OUTSIDE SNAP RING VERSION OF PT521HD. PLEASE SEE PT521HD FOR APPLICATIONS
PT1201		USE PT675
PT1202	CONVERSION	1280/1310 SPICER TO 1330 SPICER. PT521HD TO PT1203
PT1203		4 INSIDE/OUTSIDE SNAP RING VERSION OF PT530. PLEASE SEE PT530 FOR APPLICATIONS
PT1204	FORD	70 FAIRLANE; 70-73 MUSTANG; 70-74 COUNTRY SEDAN, GALAXIE; 70-76 COUNTRY SQUIRE 70-76 TORINO; 70-77 CUSTOM 500; 70-78 LTD; 72, 77-79 THUNDERBIRD; 72-76 GRAN TORINO 73-83 F100 2WD; 75-77 GRANADA; 79-03 E350 2WD; 79-83 F100 4WD; 79-88 E150 2WD 79-96 BRONCO 4WD; 79-96 E250 2WD, F150; 79-97 F250 2WD, F350; 79-98 F250 4WD 86 RANGER 4WD; 97-99 EXPLORER 2WD (INCLUDES SPORT, SPORT TRAC)
	LINCOLN	72, 77-79 MARK IV
	MAZDA	98-01 B2400 2WD; 98-06 B3000/4000 2WD; 01-07 B2300 2WD
	MERCURY	70 MARAUDER; 70-72, 74-79 COUGAR; 70-74 MONTEREY 70-76 COLONY PARK, MONTEGO; 70-78 MARQUIS; 75-78 GR. MARQUIS, MONARCH
PT1205	INTERNATIONAL	56-77 2WD/4WD TRUCKS
PT1206	HD TRUCKS	CHEVY/GMC; FORD; FREIGHTLINER; INTERNATIONAL; NAVISTAR; KENWORTH; MACK; PETERBILT; STERLING; VOLVO; WESTERN-STAR
PT10N	AGRICULTURE	L10N ROCKWELL SERIES PTO AGRICULTURAL APPLICATIONS
PT12N	AGRICULTURE	L12N ROCKWELL SERIES PTO AGRICULTURAL APPLICATIONS
PT14N	AGRICULTURE	L14N ROCKWELL SERIES PTO AGRICULTURAL APPLICATIONS
PT1601	AMC	89-96 SUMMIT; 90-95 TALON
	CHEVROLET	98-04 TRACKER
	DODGE	71-80 COLT RWD; 79-82 D50 2WD; 81-83 CHALLENGER; 82-93 RAM 50; 84-91 COLT VISTA AWD
	GEO	89-97 TRACKER
	MINI	83-96 PICKUP; 83-96, 99-06 MONTERO 4WD; 97-04 MONTERO SPORT 4WD; 03-07 OUTLANDER
	PLYMOUTH	76-79 ARROW; 79-83 ARROW PICKUP
	SUZUKI	90-95 SAMURAI 4WD; 90-98 SIDEKICK; 99-04 VITARA; 99-05 GR. VITARA; 01-05 XL-7
PT1602	INFINITI	97-03 QX4 4WD; 00-03 QX4 2WD
	NISSAN-DATSUN	70-73 510, 240Z; 73-76 610; 74 260Z; 74-77 710; 80-81 810; 84-86 PL720 P/U 4WD; 86-89 D21 P/U 4WD; 86-97 D21 P/U 2WD; 87-04 PATHFINDER 4WD; 89-04 PATHFINDER 2WD
PT1603	NISSAN-DATSUN	70-72 PL521 PICKUP; 70-73 240Z; 70-73, 78-81 510; 72-79 PL620 PICKUP; 73-76 610; 74 260Z 75-78 280Z; 79-83 280ZX; 80-83 PL720 PICKUP 4WD; 80-86 PL720 P/U 2WD; 88-89 D21 P/U 4WD
PT1604	TOYOTA	70-79 COROLLA RWD; 81-84 STARLET
PT1605	TOYOTA	70-79 COROLLA RWD; 70-82 CORONA; 71-81 CELICA; 72-73 CARINA; 78-92 CRESSIDA; 84-85 PREVIA VAN AWD
PT1606	MAZDA	71-72 '616, 618, R100; 71-73 1200; 71-74 RX-2; 72-77 808; 72-78 RX-3; 76-77 MIZER 79-83 RX-7; 80-82 626
PT1610	FORD	72-82 COURIER 2WD
	MAZDA	72-76 B1600 2WD; 74-77 ROTARY; 77-78 B1800 2WD; 79-84, 86-88 B2000 2WD 82-84, 87-93 B2200 2WD; 86-88 B2000 4WD; 87-93 B2200 4WD, B2600; 89-95 MPV 4WD
PT1616	TOYOTA	70-88 HILUX PICKUP 2WD
PT1617	TOYOTA	70-73 LAND CRUISER 4WD

APPLICATION LISTING BY PART NUMBER

PART NO. MAKE MODEL

PT1619	LEXUS	96-97 LX450 4WD; 98-06 LX470 4WD; 03-06 GX470 4WD
	TOYOTA	70-72 CROWN; 74-05 LAND CRUISER 4WD; 79-95 HILUX P/U; 84-04 4RUNNER
		86-93 SUPRA; 90-04 4RUNNER 2WD; 91-94 PREVIA VAN FWD; 93-98 T100 P/U
		95-04 TACOMA P/U; 00-07 TUNDRA 4WD; 01-04 SEQUOIA AWD
PT1620	TOYOTA	74-97 LAND CRUISER 4WD
PT1621	ACURA	96-99 SLX
	CHEVROLET	72-82 LUV PICKUP 4WD
	HONDA	94-97 PASSPORT 4WD
	ISUZU	81-95 PICKUP 4WD; 84-02 TROOPER 4WD; 86-95 PICKUP 2WD; 89-94 AMIGO
PT1622	KIA	95-02 SPORTAGE 2WD/4WD
	MAZDA	74-78 RX-4; 76-78 COSMO
PT1623	MAZDA	77-85 GLC
PT1625	CHRYSLER	87-89 CONQUEST
	DODGE	71-80 COLT RWD; 78-83 CHALLENGER; 79-82 D50 2WD; 82-93 RAM 50; 84-86 CONQUEST
	MITSUBISHI	83-89 PICKUP 4WD; 83-89, 94-98, 01-06 MONTERO 4WD; 83-96 PICKUP 2WD
	PLYMOUTH	87-90 VAN WAGON; 97-99 MONTERO SPORT 2WD; 99 MONTERO SPORT 4WD
PT1637	HD TRUCKS	ISUZU;
PT1750G	AMC	64-66 PASSENGER CAR
	FORD	60-68 FALCON, FALCON FUTURA; 64-69 MUSTANG; 61-67 E100 2WD
	MERCURY	60-65 COMET, 64-65 CYCLONE
PT2110	HD TRUCKS	AUSTIN-WESTERN, CATERPILLAR; CLARK; FIAT-ALLIS; INTERNATIONAL HARVERSTER; WABCO
PT2114	HD TRUCKS	CATERPILLAR; JOHN DEERE; GALION; INTERNATIONAL-HARVESTER
PT2116	HD TRUCKS	ALLIS-CHALMERS; AUSTIN-WESTERN; CASE; CLARK; INTERNATIONAL-HARVESTER; KOMATSU
		TOWMOTOR; WABCO
PT2117	HD TRUCKS	ALLIS-CHALMERS; CASE; CLARK; KOMATSU; TOWMOTOR
PT2126	CONVERSION	2R BW TO 2C BW. PT2127 TO PT2103
PT2127	AMC	62 AMBASSADOR; 65-66 AMERICAN
	BUICK	62-63 SPECIAL
	FORD	64-66 MUSTANG
	JEEP	64-65 WAGONEER
PT2140	CONVERSION	2R BW TO 1280/1310 SPICER. PT2127 TO PT521HD
PT2173	CONVERSION	2R BW TO PT675. PT 2127 TO PT675
PT220	CONVERSION	1550 SPICER TO 6C/62N/6CL BW. PT555 TO PT6100
PT221	CONVERSION	1550 SPICER TO 6BL BW. PT555 TO PT6106
PT231	CHRYSLER	70-75 IMPERIAL; 70-81 NEWPORT; 70-86 NEW YORKER; 75-83 CORDOBA; 77-90 LEBARON
	DODGE	70-72 CHALLENGER; 70-73 POLARA; 70-76 CORONET; 70-78 CHARGER, MONACO
		70-79 D100 P/U 2WD; 70-80 B100/200/300 VAN 2WD; 74-93 RAMCHARGER
		70-80 D200/300 P/U 2WD, W300 P/U 4WD; 75-79 W100 P/U 4WD; 76-78, 80-81 W150 P/U 4WD
		77-93 D150 P/U 2WD; 80 W200 P/U 4WD; 81, 88-93 W250 P/U 4WD; 81-01 B350 VAN 2WD
		81, 92-93 W350 P/U 4WD; 81-88 D250/350 P/U 2WD, B150/250 VAN 2WD; 94-98 RAM 1500 4WD
	87-98 DAKOTA; 94-01 B1500/2500 VAN 2WD; 94-96 RAM 2500 2WD; 94-99 RAM 1500 2WD	
	94-99 RAM 2500/3500 4WD; 98 DURANGO 4WD	
	PLYMOUTH	70 BELVEDERE; 70-74 ROADRUNNER, SATELLITE; 70-75 BARRACUDA; 70-75, 78 FURY
		70-76 DUSTER, VALIANT; 71-76 SCAMP; 74-77 GRAN FURY; 74-81 TRAILDUSTER; 76-79 VOLARE
PT233		VERSION OF PT266 WITH GREASE FITTING IN BEARING END. PLEASE SEE PT266 FOR APPLICATIONS.
PT248	JEEP	70-73 CHEROKEE 4WD, CJ5 4WD, CJ6 4WD, WAGONEER 4WD
PT2500	TOYOTA	79-95 HILUX PICKUP 4WD; 84-04 4RUNNER 4WD
PT2530	CONVERSION	2.5R BW TO 1280/1310 SPICER. PT2500 TO PT521HD

APPLICATION LISTING BY PART NUMBER

PART NO. MAKE MODEL

PT260	CHEVROLET	70-71 BLAZER 4WD; 70-76 K20 PICKUP 4WD; 70-77 K10 PICKUP 4WD
	DODGE	70-74 W100/200 PICKUP 4WD
	FORD	70-71 F100 PICKUP 4WD; 70-74 F250 PICKUP 4WD; 70-77 BRONCO 4WD
	GMC	70-71 JIMMY 4WD; 70-76 K2500 PICKUP 4WD; 70-77 K1500 PICKUP 4WD
	JEEP	70-73 J SERIES TRK 4WD; 70-73, 84-93 WAGONEER 4WD; 70-75 CJ6 4WD; 70-83 CJ5 4WD
		70-73, 84-98 CHEROKEE 4WD; 76-86 CJ7 4WD; 81-85 CJ8 4WD; 86-92 COMANCHE 4WD 87-95 WRANGLER 4WD
PT266	AMC	75-77 HORNET; 75-78 GREMLIN, MATADOR; 75-80 PACER; 78-80 AMX
		78-83 CONCORD; 79-83 SPIRIT; 80-81 EAGLE
	CHRYSLER	70-81 NEWPORT; 70-86 NEW YORKER; 75-83 CORDOBA; 77-90 LEBARON
		81-83 IMPERIAL; 83, 86-89 FIFTH AVENUE
	DODGE	70-73 POLARA; 70-74 CHALLENGER; 70-76 CORONET; 70-76, 80 W200 P/U 4WD; 70-78 MONACO
		70-78 CHARGER; 70-79 D100 P/U 2WD, W100 P/U 4WD; 70-80 B100/200/300 VAN 2WD
		70-80 D200/300 P/U 2WD; 74-93 RAMCHARGER; 75-80 W300 P/U 4WD; 76-80 ASPEN
		76-78, 80-93 W150 P/U 4WD; 77-89 DIPLOMAT; 77-93 D150 P/U 2WD; 79-81 ST. REGIS
		80-83 MIRADA; 81-93 B150/250/350 VAN 2WD, D & W 250/350 P/U; 87-98 DAKOTA
		94-96 RAM 3500 2WD
	JEEP	70-84 J SERIES TRK 2WD, WAGONEER 2WD; 74-84 CHEROKEE 2WD
		74-83 CHEROKEE 4WD, WAGONEER 4WD; 81-84 CJ8 2WD; 84 GR. WAGONEER 2WD
	PLYMOUTH	70 BELVEDERE; 70-74 ROADRUNNER, SATELLITE; 70-75 BARRACUDA; 70-75, 78 FURY
	70-76 DUSTER, VALIANT; 71-76 SCAMP; 74-77, 80-89 GR FURY; 74-81 TRAILDUSTER 76-79 VOLARE	
PT279	HD TRUCKS 1610 SERIES	CHEVY/GMC; FORD; FREIGHTLINER; INTERNATIONAL; NAVISTAR; KENWORTH; MACK PETERBILT; STERLING; VOLVO; WESTERN-STAR
PT279HR	HD TRUCKS 1610-HR SERIES	CHEVY/GMC; FORD; FREIGHTLINER; INTERNATIONAL; NAVISTAR; KENWORTH; MACK PETERBILT; STERLING; VOLVO; WESTERN-STAR
PT279HRK	HD TRUCKS 1610-HR SERIES	VERSION OF PT279HR. INCLUDES PT111UJ BEARING CLAMP KIT
PT280	HD TRUCKS 1710 SERIES	CHEVY/GMC; FORD; FREIGHTLINER; INTERNATIONAL; NAVISTAR; KENWORTH; MACK PETERBILT; STERLING; VOLVO; WESTERN-STAR
PT280HR	HD TRUCKS 1710-HR SERIES	CHEVY/GMC; FORD; FREIGHTLINER; INTERNATIONAL; NAVISTAR; KENWORTH; MACK PETERBILT; STERLING; VOLVO; WESTERN-STAR
PT280HRK	HD TRUCKS 1710-HR SERIES	VERSION OF PT280HR. INCLUDES PT112UJ BEARING CLAMP KIT
PT281	HD TRUCKS 1810 SERIES	CHEVY/GMC; FORD; FREIGHTLINER; INTERNATIONAL; NAVISTAR; KENWORTH; MACK PETERBILT; STERLING; VOLVO; WESTERN-STAR
PT281HR	HD TRUCKS 1810-HR SERIES	CHEVY/GMC; FORD; FREIGHTLINER; INTERNATIONAL; NAVISTAR; KENWORTH; MACK PETERBILT; STERLING; VOLVO; WESTERN-STAR
PT281HRK	HD TRUCKS 1810-HR SERIES	VERSION OF PT281HR. INCLUDES PT112UJ BEARING CLAMP KIT
PT297	CHEVROLET	70-86 K10/20 PICKUP 4WD; 72-91 BLAZER 4WD; 87 V10/20 PICKUP 4WD
	DODGE	70-76, 80 W200 P/U 4WD; 70-79 W100 P/U 4WD; 74-93 RAMCHARGER 4WD; 75-80 W300 4WD
		76-78, 80-93 W150 4WD; 81-93 W250/350 4WD; 94-01 RAM 1500 4WD; 94-99 RAM 2500 4WD
	FORD	72-83 F100 4WD; 75-96 F150 4WD; 75-98 F250 4WD; 78-96 BRONCO 4WD; 80-81 F350 4WD
		90 BRONCO II 4WD; 90-97 RANGER 4WD; 91-94 EXPLORER 4WD (INC. SPORT, SPORT TRAC)
	GMC	70-86 K1500/2500 P/U 4WD; 72-91 JIMMY 4WD; 87 V1500/2500 P/U 4WD
	JEEP	74-83 WAGONEER 4WD; 74-83, 93-01 CHEROKEE 4WD; 74-88 J SERIES TRK 4WD
		84-91, 93 GRAND WAGONEER 4WD; 93-97, 99-01 GR. CHEROKEE 4WD; 97-07 WRANGLER 4WD
	MAZDA	91-94 NAVAJO 4WD; 94-96 B3000 4WD; 94-97 B2300/4000 4WD
PLYMOUTH	74-81 TRAILDUSTER 4WD	
PT308	HD TRUCKS 1880 SERIES	CHEVY/GMC; FORD; FREIGHTLINER; INTERNATIONAL; NAVISTAR; KENWORTH; MACK PETERBILT; STERLING; VOLVO; WESTERN-STAR

APPLICATION LISTING BY PART NUMBER

PART NO. MAKE MODEL

PT3105	BUICK	70 WILDCAT; 70-72, 75-98 SKYLARK; 70-78 RIVIERA; 70-89 ELECTRA; 70-89 LESABRE 71-73 CENTURION; 73-81 CENTURY; 77-87 REGAL; 90 ESTATE SW; 91-96 ROADMASTER 04-06 RANIER	
	CADILLAC	70-76 CALAIS; 70-84 DEVILLE; 70-96 FLEETWOOD; 76-79 SEVILLE; 89-92 BROUGHMAN 99-00, 02-06 ESCALADE 4WD; 02-04 ESCALADE 2WD	
	CHEVROLET	70-02 CAMARO; 70-72 BISCAYNE, BROOKWOOD; 70-77 BEL AIR; 70-96 CAPRICE 70-85, 94-96 IMPALA; 70-89 P10 VAN 2WD; 70-94 BLAZER 2WD; 71-73 CHEVELLE 70-95 G10 2WD; 71-88 MONTE CARLO; 72-94 BLAZER 4WD; 73-83 MALIBU; 73-87 EL CAMINO 76-89 P20 VAN 2WD; 76-95 G20 VAN 2WD; 77-86 K20 P/U 4WD; 78, 82-86 C10 P/U 2WD 78-86 K10 P/U 4WD; 78-90 G30 VAN 2WD, P30 VAN 2WD; 80-86 K30 P/U 4WD; 82-01 S-10 P/U 81-86 C20 P/U 2WD; 83-05 S-10 BLAZER; 85-05 ASTRO VAN; 87 R&V10/20 P/U; 87-88 V30 4WD 88-99 C1500 P/U 2WD, K1500/2500/3500 PICKUP 4WD; 89-91 V3500 P/U 4WD; 95-06 TAHOE 96 G1500 2WD; 96-02 G2500 VAN 2WD; 99-04 SILVERADO 2500 4WD; 99-06 SILVERADO 1500 00-06 SUBURBAN 1500/2500 4WD; 02-06 TRAILBLAZER; 01-06 SILVERADO 2500HD/3500 4WD 02-06 AVALANCHE 1500/2500 4WD; 03-06 EXPRESS 1500/2500 VAN 4WD; 03-06 SSR	
	DODGE	74-93 RAMCHARGER 4WD; 75-76, 80 W200 P/U 4WD; 75-79 W100 P/U 4WD 75-80 W300 P/U 4WD; 76-78, 80-93 W150 P/U 4WD; 81-93 W250/350 P/U 4WD 03-06 RAM 2500/3500 4WD; 04-06 DURANGO	
	FORD	70-71, 79 THUNDERBIRD; 79-86 F150 2WD; 81 F100 2WD; 88 F350 4WD	
	GMC	70-89 P1500 VAN 2WD; 70-96 G1500 VAN 2WD; 73-77 SPRINT; 76-02 G2500 VAN 2WD 76-89 P2500 VAN 2WD; 77-86, 88-99 K2500 P/U 4WD; 78, 82-86, 88-99 C1500 P/U 2WD 78-86, 88-99 K1500 P/U 4WD; 78-87 CABALLERO; 78-90 G3500/P3500 VAN 2WD 78-93 JIMMY 4WD; 81-86 C2500 P/U 2WD; 80-86, 88-99 K3500 P/U 4WD; 82-90 S15 P/U 82-93 JIMMY 2WD; 83-91 S15 JIMMY; 85-05 SAFARI VAN FWD; 87 R&V1500/2500 P/U 87-91 V3500 PICKUP 4WD; 90-05 SAFARI VAN AWD; 91-04 SONOMA P/U 98-00, 02-06 ENVOY; 00-04 SIERRA 2500 4WD; 00-06 SIERRA 1500, YUKON XL1500 00-06 YUKON XL1500; 01-06 SIERRA 2500HD/3500 4WD 03-06 SAVANA 1500/2500 VAN 4WD	
	HUMMER	03-06 H2 4WD	
	ISUZU	96-00 HOMBRE; 03-07 ASCENDER	
	LINCOLN	78-79 CONTINENTAL	
	MERCURY	79 COUGAR	
	OLDSMOBILE	70-72 F85; 70-75 OLDS 98 RWD; 70-77 VISTA CRUISER; 70-79 LUXURY 98 RWD 70-88 CUTLASS RWD, DELTA 88 RWD; 71-79, 85-92 CUSTOM CRUISER RWD 73-79 REGENCY 98; 73-84 NINETY EIGHT RWD; 74-76 SUPREME CRUISER 76 OMEGA, STARFIRE; 91-94, 96-04 BRAVADA 4WD; 02-04 BRAVADA 2WD	
	PLYMOUTH	74-81 TRAILDUSTER 4WD	
	PONTIAC	70 EXECUTIVE RWD; 70-81 CATALINA RWD, LEMANS RWD; 70-87 GR. PRIX 70-89 BONNEVILLE RWD; 71-75 GRANDVILLE RWD; 71-78 GR. SAFARI RWD 76-02 FIREBIRD; 77 VENTURA; 82-91 6000 AWD; 83-86 PARISIENNE; 87-89 SAFARI	
	PT315	AMC	1975 GREMLIN, HORNET
		FORD	83-89 RANGER 4WD; 84-85 BRONCO II 4WD; 86-89 RANGER 2WD 86-94 TEMPO AWD; 90-97 AEROSTAR AWD
		MERCURY	87-91 TOPAZ AWD
		PONTIAC	82-91 '6000 AWD
	PT3152	HD TRUCKS	CASE; CATERPILLAR; GALION; HYSTER; INTERNATIONAL-HARVESTER; WABCO

APPLICATION LISTING BY PART NUMBER

PART NO. MAKE MODEL

PT3188	CHEVROLET	70 BEL AIR, BISCAYNE, BROOKWOOD, CAPRICE, IMPALA; 71-72 CHEVELLE; 71-72 MONTE CARLO
		76-80 P20 VAN 2WD; 76-80, 91-95 G20 VAN 2WD; 79-81 C10 P/U 2WD; 88 V30 P/U 4WD
		88-91 K3500 P/U 4WD; 88-99 C1500 2WD, K1500/2500 P/U 4WD; 89-91 V3500 P/U 4WD
		91-95 G10 VAN 2WD; 94 BLAZER 4WD; 94-96 S-10 P/U 2WD; 94-99 C1500 SUBURBAN 2WD
		95-01 S-10 P/U 4WD; 96 G1500 VAN 2WD; 99-06 SILVERADO 1500
		00-06 SUBURBAN 1500 2WD; 02-06 AVALANCHE 1500 2WD; 04-06 COLORADO
	FORD	86-96 BRONCO 4WD; 88 F350 4WD
	GMC	76-80 P2500 VAN 2WD; 76-80, 91-95 G2500 VAN 2WD; 79-81, 88-99 C1500 2WD
		88-91 K&V3500 P/U 4WD; 88-99 K1500/2500 P/U 4WD; 91-96 G1500 VAN 2WD
		94-96 SONOMA P/U 2WD; 94-99 C1500 SUBURBAN 2WD; 95-96 SONOMA P/U 4WD
	00-06 SIERRA 1500, YUKON XL1500; 04-06 CANYON	
OLDSMOBILE	70 CUTLASS, DELTA 88 RWD, F85, LUXURY 98 RWD, OLDS 98 RWD; VISTA CRUISER	
PT320	CONVERSION	7260 DETROIT TO PT675. PT266 TO PT675
PT324	CONVERSION	1810 SPICER TO 9C BW. PT281 TO PT9031
PT326	CONVERSION	1880 SPICER TO 9C BW. PT308 TO PT9031
PT328	CONVERSION	1550 SPICER TO 58WB ROCKWELL. PT555 TO PT58WB1
PT329	CONVERSION	1550 SPICER TO 58WB1 ROCKWELL. PT555 TO PT58WB1
PT331	CONVERSION	1650 SPICER TO 7CL BW. PT565 TO PT7100
PT332	CHEVROLET	77-86 K30 P/U 4WD; 87-88 V30 P/U 4WD; 88-91 K3500 P/U 4WD; 89-91 V3500 P/U 4WD
	DODGE	75-76, 80 W200 P/U 4WD; 75-80 W300 P/U 4WD; 81-93 W250/350 P/U 4WD
		94-02 RAM 2500/3500 4WD
	FORD	78-79, 99 F250 4WD; 79, 85-97 F350 4WD; 99-04 F450SD/550SD 4WD
		99-06 F250SD/350SD 4WD; 00-04 EXCURSION 4WD
GMC	77-86, 88-91 K3500 P/U 4WD; 87-91 V3500 P/U 4WD	
PT345	CONVERSION	1410 SPICER TO 4BL BW. PT560 TO PT4113
PT348	CONVERSION	1480 SPICER TO 5C/5CL BW. PT588 TO PT5100
PT350	CHEVROLET	76-87 CHEVETTE
	PONTIAC	81-87 T1000
PT352	FORD	1979 THUNDERBIRD
	MERCURY	1979 COUGAR
PT353	AMC	78-80 AMX; 78-83 CONCORD; 79-80 PACER; 79-83 SPIRIT; 80-81 EAGLE
PT354	CONVERSION	7290 DETROIT TO 1280/1310 SPICER. PT231 TO PT521HD
PT355	CONVERSION	7290 DETROIT TO 3R BW. PT231 TO PT3105
PT356	PONTIAC	88-93 FIREBIRD
PT357	CONVERSION	5380 DETROIT TO 1410 SPICER. PT373 TO PT560
PT358	CONVERSION	1280/1310 SPICER TO 1350 SPICER. PT521HD TO PT578
PT35N	AGRICULTURE	35N ROCKWELL SERIES PTO AGRICULTURAL APPLICATIONS
PT360	CONVERSION	7290 DETROIT TO 7260 DETROIT. PT231 TO PT266
PT362	DODGE	94-01 B1500/2500 VAN 2WD, B350 VAN 2WD; 94-99 RAM 1500 2WD, RAM 2500/3500 4WD
		97-98 RAM 2500 2WD; 98-99 RAM 1500 4WD; 99 DAKOTA, DURANGO 4WD
PT366	CONVERSION	3R BW TO 1350 SPICER. PT3105 TO PT578
PT370	CONVERSION	1280/1310 SPICER TO 3C BW. PT521HD TO PT3152
PT373	DODGE	70-76 W300 P/U 4WD; 82-89 W350 P/U 4WD
PT402	CONVERSION	1350 SPICER TO P55 CLEVELAND/1330 SPICER. PT578 TO PT1203
PT407	HD TRUCKS	CHEVY/GMC; FORD; FREIGHTLINER; INTERNATIONAL; NAVISTAR; KENWORTH; MACK
	1760 SERIES	PETERBILT; STERLING; VOLVO; WESTERN-STAR
PT407HR	HD TRUCKS	CHEVY/GMC; FORD; FREIGHTLINER; INTERNATIONAL; NAVISTAR; KENWORTH; MACK
	1760-HR SERIES	PETERBILT; STERLING; VOLVO; WESTERN-STAR
PT407HRK	HD TRUCKS	VERSION OF PT407HR. INCLUDES PT112UJ BEARING CLAMP KIT
	1760-HR SERIES	
PT408	SUZUKI	99-05 GR. VITARA; 01-05 XL-7
PT4100	HD TRUCKS	CATERPILLAR; CLARK; FIAT-ALLIS; INTERNATIONAL-HARVESTER; MASSEY-FERGUSON; STEIGER
PT4101	HD TRUCKS	ALLIS-CHALMERS; CATERPILLAR; HYSTER; INTERNATIONAL-HARVESTER; TOWMOTOR

APPLICATION LISTING BY PART NUMBER

PART NO. MAKE MODEL

PT411	ACURA	98-99 SLX
	ISUZU	98-02 TROOPER 4WD; 00-02 TROOPER 2WD
PT4113	HD TRUCKS	CATERPILLAR; CLARK; EATON; INTERNATIONAL-HARVESTER; KOMATSU
PT4140	CONVERSION	4BL BW TO 4C BW. PT4113 TO PT4100
PT424	FORD	05-06 F450/550 SUPER DUTY 4WD
PT445	BUICK	04-06 RANIER 4WD
	CHEVROLET	82-01 S-10 P/U 4WD; 83-05 S-10 BLAZER 4WD; 02-06 TRAILBLAZER; 04-05 ASTRO VAN AWD
	GMC	82-90 S15 P/U 4WD; 83-91 S15 JIMMY 4WD; 91-04 SONOMA P/U 4WD; 98-00, 02-06 ENVOY 4WD
	HUMMER	2006 H3 4WD
	ISUZU	98-00 HOMBRE 4WD; 03-07 ASCENDER 4WD
	OLDSMOBILE	02-04 BRAVADA 4WD
PT446	INFINITI	97-03 QX4 4WD
	NISSAN-DATSUN	86-89 D21 PICKUP 4WD; 87-04 PATHFINDER 4WD
PT44N	AGRICULTURE	44N ROCKWELL SERIES PTO AGRICULTURAL APPLICATIONS
PT450	MITSUBISHI	89-00 MONTERO 4WD; 90-96 PICKUP 4WD; 97-04 MONTERO SPORT
PT455	CHEVROLET	83-94 S-10 BLAZER 4WD; 88-94 S-10 P/U 4WD
	GMC	88-90 S15 P/U 4WD; 88-91 S15 JIMMY 4WD; 91-94 SONOMA P/U 4WD
PT456	FORD	84-90 BRONCO II 4WD; 85-97 RANGER 4WD; 91-94 EXPLORER 4WD (INC. SPORT, SPORT TRAC)
	MAZDA	91-94 NAVAJO 4WD
PT457	CONVERSION	7260 DETROIT TO P55 CLEVELAND/1330 SPICER. PT266 TO PT1203
PT459	CONVERSION	1350 SPICER TO P55 CLEVELAND/1330 SPICER. PT578 TO PT1204
PT462	HD TRUCKS	87-95 GM 60/70 TILT CAB, ISUZU FSR & FTR
PT464	DODGE	03-06 RAM 2500/3500 4WD
PT495		VERSION OF PT521HD WITH GREASE FITTING IN BEARING END. PLEASE SEE PT521HD FOR APPLICATIONS.
PT496		VERSION OF PT260 WITH GREASE FITTING IN BEARING END. PLEASE SEE PT260 FOR APPLICATIONS.
PT497		VERSION OF PT297 WITH GREASE FITTING IN BEARING END. PLEASE SEE PT297 FOR APPLICATIONS.
PT498		VERSION OF PT578 WITH GREASE FITTINGS IN ALL BEARING ENDS. PLEASE SEE PT578 FOR APPLICATIONS.
PT501		VERSION OF PT514 WITH NO GREASE FITTING. PLEASE SEE PT514 FOR APPLICATIONS
PT503		USE PT510
PT504	LANDROVER	87-02 RANGE ROVER; 93 DEFENDER 110; 94-04 DISCOVERY; 94-95, 97 DEFENDER 90
PT510		NEAPCO 675 SERIES PTO
PT5100	HD TRUCKS	AUSTIN-WESTERN, CATERPILLAR; CLARK; DYNAPAK; FIAT-ALLIS; INTERNATIONAL HARVESTER
		WABCO
PT5101	CONVERSION	5C BW TO 5C BW. PT 5105 TO PT5100
PT5102	CONVERSION	5C BW TO 5BL BW. PT 5108 TO PT5100
PT5108	HD TRUCKS	CASE; CATERPILLAR; CLARK; JOHN DEERE; EATON; FIAT-ALLIS; INTERNATIONAL HARVESTER
		KOMATSU
PT5110	CONVERSION	5C BW TO 5R BW. PT5105 TO PT5109
PT5111	CONVERSION	5R BW TO 5BL BW. PT 5109 TO PT5108
PT514	ALFA-ROMEO	70-94 SPIDER; 81-86 GTV; 87-89 MILANO; 91-95 164
	CHEVROLET	72-82 LUV PICKUP
	FIAT	70-73 850; 70-78 124; 71-79 128; 74-83 X1/9; 75-78 131; 79-81 BRAVA; 79-83 SPIDER
	ISUZU	81-87 PICKUP; 84-86 TROOPER 4WD
	PLYMOUTH	71-73 CRICKET
PT514CL		VERSION OF PT514 WITH GREASE FITTING IN CENTER OF CROSS. PLEASE SEE PT514 FOR APPLICATIONS.
PT515	HD TRUCKS	1500 SERIES GM; INTERNATIONAL HARVESTER; MACK

APPLICATION LISTING BY PART NUMBER

PART NO. MAKE MODEL

PT521HD	AMC	70-74 AMBASSADOR; 70-74, 78-80 AMX; 70-77 HORNET; 70-78 GREMLIN, MATADOR 75-80 PACER; 78-83 CONCORD; 79-83 SPIRIT; 80-88 EAGLE
	BUICK	70-72, 75-98 SKYLARK; 73-75 APOLLO; 75-80 SKYHAWK
	CHEVROLET	70 IMPALA; 70, 80-82, 84-99 CORVETTE; 70-79 NOVA; 70-87 EL CAMINO; 70-72 BROOKWOOD 70-72 BEL AIR, BISCAYNE, CAPRICE, CHEVELLE, MONTE CARLO; 70-77 G30/P30 VAN 2WD 70-78 C30 P/U 2WD; 70-81 BLAZER 2WD; 70-81 C10/20 P/U 2WD, G20/P20 VAN 2WD 70-86 K10/20 P/U 4WD; 70-89 P10 VAN 2WD; 70-90 G10 VAN 2WD; 70-91 BLAZER 4WD 70-92 CAMARO; 71-81 VEGA; 75-80 MONZA; 77-86 K30 P/U 4WD; 83-94 S-10 BLAZER 4WD 87 V10/20 P/U 4WD; 87-88 V30 P/U 4WD; 88-91 K3500 P/U 4WD; 88-94 S-10 P/U 4WD 89-91 V3500 P/U 4WD; 04-06 COLORADO 4WD
	DODGE	74-77 RAMCHARGER 4WD; 75-76 W100/200/300 4WD; 76 W150 4WD; 98-06 DURANGO 4WD
	FORD	70 FAIRLANE, FALCON; 70-74 COUNTRY SEDAN, GALAXIE, E200/300 VAN 2WD; 70-76 F350 2WD 70-76 TORINO; 70-76, 79 COUNTRY SQUIRE; 70-78 BRONCO 4WD; 70-77 CUSTOM 500 70-77 MAVERICK; 70-78 E100 2WD, F100 4WD, F250; 70-79 F100 2WD; 70-91 LTD; 71-80 PINTO 70-95 MUSTANG; 72-76 GR. TORINO; 75-83 GRANADA; 75-78 E150 2WD, F150 4WD 75-86 F150 2WD; 78-83 FAIRMONT; 80-93 THUNDERBIRD; 83-06 RANGER 4WD 83-97 RANGER 2WD; 84-90 BRONCO II 4WD; 86-97 AEROSTAR FWD; 90-97 AEROSTAR AWD 91-96 EXPLORER 2WD/4WD (INCLUDES SPORT, SPORT TRAC); 92-94 CR. VICTORIA
	GMC	70-77 G3500/P3500 VAN 2WD; 70-78 C3500 P/U 2WD; 70-86 K1500/2500 P/U 4WD 70-81 C1500/2500 P/U 2WD, G2500/P2500 VAN 2WD, JIMMY 2WD; 70-89 P1500 VAN 2WD 70-90 G1500 VAN 2WD; 70-91 JIMMY 4WD; 71-77 SPRINT; 77-86, 88-91 K3500 P/U 4WD 78-87 CABALLERO; 87 V1500/2500 4WD; 87-91 V3500 4WD; 88-90 S15 P/U 4WD; 92-07 YUKON 88-91 S15 JIMMY 4WD; 91-94 SONOMA 4WD; 99-00 YUKON DENALI; 04-06 CANYON 4WD
	HONDA	94-02 PASSPORT
	ISUZU	81-95 PICKUP 4WD; 88-95 PICKUP 2WD; 91-04 RODEO; 98-00 AMIGO; 02-04 AXIOM
	JAGUAR	70-74 XKE; 70-85 XJ-6; 73-79 XJ-12; 76-85 XJ-S
	JEEP	70-01 CHEROKEE 4WD; 70-73 DJ5 2WD; 70-75 CJ6 4WD; 70-83 CJ5 4WD; 70-88 J SERIES TRK 70-93 WAGONEER; 74-01 CHEROKEE 2WD; 76-86 CJ7 4WD; 81-85 CJ8; 86-92 COMANCHE 84-91, 93 GR. WAGONEER; 87-95 WRANGLER 2WD; 87-95, 97-07 WRANGLER 4WD 93-04 GR. CHEROKEE 4WD; 93-07 GR. CHEROKEE 2WD; 02-07 LIBERTY
	LINCOLN	79-80 VERSAILLES; 80-92 MARK SERIES; 80-87 CONTINENTAL; 82-94 TOWN CAR
	MAZDA	91-94 NAVAJO; 94-06 B4000 4WD; 94-96 B3000 2WD; 94-96, 98-06 B3000 4WD 94-97 B2300/4000 2WD; 94-97, 01-06 B2300 4WD; 98-01 B2400 4WD; 01-06 TRIBUTE 4WD
	MERCURY	70-73, 80-93 COUGAR; 70-76 MONTEGO; 71-77 COMET; 75-80 BOBCAT, MONARCH 77-82 MARQUIS; 77-94 GR. MARQUIS; 78-83 ZEPHYR; 79 COLONY PARK 79-86 CAPRI; 83-86 MID MARQUIS; 97-07 MOUNTAINEER 4WD; 05-07 MARINER 4WD
	MINI	06-07 RAIDER 4WD
	NISSAN-DATSUN	86-95 D21 P/U 2WD; 86-97 D21 P/U 4WD; 98-07 FRONTIER 4WD; 02-04 FRONTIER 2WD 04-07 PATHFINDER ARMADA 4WD, TITAN 4WD; 05-07 PATHFINDER 4WD
	OLDSMOBILE	73-79 OMEGA; 75-80 STARFIRE; 91-94 BRAVADA 4WD
	PLYMOUTH	74-81 TRAILDUSTER 4WD
	PONTIAC	70-75, 88-93 FIREBIRD; 70-77 VENTURA; 75-77 ASTRE; 76-80 SUNBIRD; 77-79 PHOENIX
	TOYOTA	89-95 HILUX PICKUP 2WD; 93-98 T100 2WD; 95-04 TACOMA 2WD 00-04 TUNDRA 2WD; 00-07 TUNDRA 4WD; 01-04 SEQUOIA
	PT521HDP	NON-LUBEABLE VERSION OF PT521HD. PLEASE SEE APPLICATIONS FOR PT521HD
	PT521HDU	KIT INCLUDES PT102UJ HARDWARE KIT. PLEASE SEE APPLICATIONS FOR PT521HD
	PT524	HD TRUCKS 1800 SERIES

APPLICATION LISTING BY PART NUMBER

PART NO. MAKE MODEL

PT530	CHEVROLET	70-77 C10 P/U 2WD; 70-78 C30 P/U 2WD; 70-80 C20 P/U 2WD; 70-82 CORVETTE 75-77 G30/P30 VAN 2WD; 76-80 P20 VAN 2WD; 76-80, 91-95 G20 VAN 2WD 88 V30 P/U 4WD; 88-91 K3500 P/U 4WD; 88-99 C1500 P/U 2WD; 88-99 K1500/2500 P/U 4WD; 89-91 V3500 P/U 4WD; 91-95 G10 VAN 2WD 94 BLAZER 4WD; 94-96 S-10 P/U 2WD; 94-99 C1500 SUBURBAN 2WD 95-01 S-10 P/U 4WD; 96 G1500 VAN 2WD; 99-06 SILVERADO 1500 00-06 SUBURBAN 1500 2WD; 02-06 AVALANCHE 1500 2WD; 04-06 COLORADO	
	CHRYSLER	70-75 IMPERIAL	
	DODGE	94-01 B350 VAN 2WD; 94-03 B1500/2500 VAN 2WD; 99-03 DURANGO 4WD 94-06 RAM 1500/2500/3500 4WD; 99-06 DAKOTA; 00-03 DURANGO 2WD; 00-06 RAM 1500 2WD	
	FORD	70 FAIRLANE; 70-73, 87-04 MUSTANG; 70-74 COUNTRY SEDAN, GALAXIE; 70-76 TORINO 70-76, 79 COUNTRY SQUIRE; 70-77 CUSTOM 500; 70-91 LTD; 70-97 F250/350 2WD 72-76 GR. TORINO; 72-79, 87-97 THUNDERBIRD; 73-83 F100 2WD; 75-03 E350 2WD 75-04 F150; 75-77 GRANADA; 75-83 E100 2WD; 75-96 E150/250 2WD; 77-99 F250 4WD 78-96 BRONCO 4WD; 79-83 F100 4WD; 79-97 F350 4WD; 86, 98-06 RANGER 4WD 90-97 AEROSTAR FWD; 91-06 EXPLORER 4WD (INC SPORT, SPORT TRAC); 92-06 CR VICTORIA 95-06 EXPLORER 2WD (INC SPORT, SPORT TRAC); 97-02 EXPEDITION 2WD 97-06 EXPEDITION 4WD; 98-06 RANGER 2WD	
	GMC	70-77, 88-99 C1500 P/U 2WD; 70-78 C3500 P/U 2WD; 70-80 C2500 P/U 2WD 75-77 G3500/P3500 VAN 2WD; 76-80 P2500 VAN 2WD; 76-80, 91-95 G2500 VAN 2WD 88-91 K3500/V3500 P/U 4WD; 88-99 K1500/2500 P/U 4WD; 91-96 G1500 VAN 2WD 94-96 SONOMA P/U 2WD; 94-99 C1500 SUBURBAN 2WD; 95-96 SONOMA P/U 4WD 00-06 SIERRA 1500 P/U, YUKON XL1500; 04-06 CANYON	
	JEEP	98, 02-04 GR. CHEROKEE 4WD; 99-01 CHEROKEE 4WD; 00-01 GR. CHEROKEE 2WD 02-03 LIBERTY 2WD; 02-07 LIBERTY 4WD	
	LINCOLN	70-83 MARK SERIES; 70-77, 80-81 CONTINENTAL; 77-78 VERSAILLES; 82-07 TOWN CAR 93-98 MARK VIII; 98-06 NAVIGATOR 4WD; 02 BLACKWOOD 4WD; 03-05 AVIATOR 05-06 NAVIGATOR 2WD	
	MAZDA	94-06 B4000 4WD; 94-96, 98-06 B3000 4WD; 94-97, 01-06 B2300 4WD 98-01 B2400; 98-06 B3000/4000 2WD; 01-07 B2300 2WD	
	MERCURY	70, 03-04 MARAUDER; 70-72, 74-79, 89-97 COUGAR; 70-74 MONTEREY; 70-76 MONTEGO 70-76, 79 COLONY PARK; 70-82 MARQUIS; 75-07 GR. MARQUIS; 75-78 MONARCH 83-86 MID MARQUIS; 97-07 MOUNTAINEER	
	MITSUBISHI	06-07 RAIDER	
	NISSAN-DATSUN	05-07 FRONTIER, PATHFINDER	
	OLDSMOBILE	70 CUTLASS, DELTA 88 RWD, F85, LUXURY 98 RWD, OLDS 98 RWD; VISTA CRUISER	
	TOYOTA	2005 TACOMA 2WD	
	PT534	FORD	70-74 F350 2WD; 70-78 F250 4WD; 73-78 F100 2WD; 75-77 F250 2WD; 75-78 F150 2WD
	PT555	HD TRUCKS	CHEVY/GMC; FORD; FREIGHTLINER; INTERNATIONAL; NAVISTAR; KENWORTH; MACK PETERBILT; STERLING; VOLVO; WESTERN-STAR
		ISUZU	91-94 FRR & NRR 2WD
		CHEVY/GMC	91-94 TILTMASTER 5000 2WD
	PT55N	AGRICULTURE	55N ROCKWELL SERIES PTO AGRICULTURAL APPLICATIONS
	PT560	CHEVROLET	88-00 C3500 P/U/SUBURBAN 2WD; 91 R3500 P/U 2WD; 91-02 C3500HD 2WD 91-02 P30 VAN 2WD; 96-02 G3500 VAN 2WD; 99-00 SILVERADO 2500 4WD 99-01 SILVERADO 2500 2WD; 00-06 SUBURBAN 2500 4WD; 03-06 EXPRESS 3500 2WD 01-06 SILVERADO 2500HD/3500, SUBURBAN 2500 2WD; 02-06 AVALANCHE 2500
		DODGE	82-93 W350 P/U 4WD; 88-93 W250 P/U 4WD, D250/350 P/U 2WD; 94-01 B1500/2500 VAN 2WD 94-03 B350 VAN 2WD; 94-06 RAM 2500/3500; 04-06 RAM 1500 2WD
		FORD	97-98 E SUPER DUTY; 99 F250 4WD; 99-06 E450, F250SD, F350SD 2WD; 00-04 EXCURSION; 04 E350 2WD; 05-06 F350SD 4WD
		GMC	88-00 C3500 2WD; 91 R3500 2WD; 91-02 C3500HD 2WD; 91-99 P3500 2WD; 96-02 G3500 2WD 2000 SIERRA 2500 4WD; 00-01 SIERRA 2500 2WD; 01-06 SIERRA 2500HD/3500

APPLICATION LISTING BY PART NUMBER

PART NO. MAKE MODEL

PT565	HD TRUCKS	1650 SERIES DODGE, FORD, GM, INTERNATIONAL HARVESTER, MACK
PT570	HD TRUCKS	CHEVY/GMC; DODGE; FORD; FREIGHTLINER; INTERNATIONAL; NAVISTAR; KENWORTH; MACK PETERBILT; STERLING; VOLVO; WESTERN-STAR
	DODGE	59-71 W300 P/U 4WD; 61-67 W200 P/U 4WD; 58-71 W100 P/U 4WD
PT576	CONVERSION	PT510 TO PT6N8
PT578	BUICK	70-89 ELECTRA, LESABRE; 82-87 REGAL
	CADILLAC	82-84 DEVILLE; 05-06 ESCALADE 2WD
	CHEVROLET	70-81 BLAZER 2WD; 70-82, 84-99 CORVETTE; 70-86 C10/20/30 P/U 2WD; 70-86 K20 P/U 4WD 70-89 P10 VAN 2WD; 70-92 CAMARO; 70-95 G10 VAN 2WD; 75-02 P30 VAN 2WD 75-96 G30 VAN 2WD; 76-81 G20/P20 VAN 2WD; 77-86 K30 P/U 4WD; 82-83 MALIBU 78, 82-86 K10 P/U 4WD; 82-84 MONTE CARLO; 82-85 IMPALA; 82-91 BLAZER 4WD 82-96 CAPRICE; 85-03 ASTRO VAN; 87 R10 P/U 2WD, V10/20 P/U 4WD; 87-88 V30 P/U 4WD 87-88 R20/30 P/U 2WD; 88-00 C2500 P/U 2WD, C3500 P/U/SUBURBAN 2WD 88-99 C1500 P/U 2WD, K1500/2500/3500 P/U 4WD; 89-91 R3500 P/U 2WD, V3500 P/U 4WD 91-01 C3500HD P/U 2WD; 94-99 C2500 SUBURBAN 2WD; 95-05 S-10 BLAZER 4WD 95-99 C1500 SUBURBAN 2WD; 96-02 G1500/2500/3500 VAN 2WD; 99-04 SILVERADO 2500 00 SUBURBAN 1500 4WD; 00-06 SUBURBAN 2500; 02-06 SILVERADO 1500 4WD 03-06 EXPRESS 1500/2500, EXPRESS 3500 2WD
	DODGE	70-74 W200 P/U 4WD; 92-04 VIPER; 04-06 RAM 1500 2WD; 05-06 RAM 2500/3500 4WD
	FORD	70-74 E300 VAN 2WD; 70-78, 80-99 F250 4WD; 70-97 F350 2WD; 75-79, 87-99 F250 4WD 79, 90-04 E350 VAN 2WD; 80-85, 87-97 F350 4WD; 97-03 F150 4WD; 97-04 F150 2WD 97-06 E150/250 VAN 2WD; 97-06 EXPEDITION; 99-04 F350SD 2WD; 00-04 EXCURSION 99-06 F250SD/350SD/450SD/550SD 4WD; 01-04 MUSTANG; 02-04 E450
	GMC	70-02 G1500 VAN 2WD; 70-84 JIMMY 2WD; 70-86, 88-00 C2500/3500 P/U 2WD 70-86, 88-99 C1500 P/U 2WD, K2500 P/U 4WD; 70-89 P1500 VAN 2WD; 75-02 G3500 VAN 2WD 75-99 P3500 VAN 2WD; 76-81 P2500 VAN 2WD; 76-81, 96-02 G2500 VAN 2WD 77-86, 88-99 K3500 P/U 4WD; 78, 82-86, 88-89 K1500 P/U 4WD; 82-91 JIMMY 4WD 85-02 SAFARI VAN FWD; 87 R1500/2500 P/U 2WD, V1500/2500 P/U 4WD; 87-91 R3500 P/U 2WD 87-91 V3500 4WD; 90-05 SAFARI VAN AWD; 91-01 C3500HD 2WD; 94-99 C2500 SUBURBAN 2WD 95-99 C1500 SUBURBAN 2WD; 00-04 SIERRA 2500; 02-06 SIERRA 1500 4WD 02-06 YUKON XL1500 4WD; 03-06 SAVANA 1500/2500; 03-06 SAVANA 3500 2WD
	HUMMER	03-06 H2 4WD; 2006 H3 4WD
	INFINITI	04-07 QX56
	LINCOLN	98-04 NAVIGATOR 2WD; 98-06 NAVIGATOR 4WD; 02 BLACKWOOD
	NISSAN-DATSUN	04-07 PATHFINDER ARMADA, TITAN
	OLDSMOBILE	82-84 DELTA 88 RWD, NINETY EIGHT RWD; 82-88 CUTLASS
	PONTIAC	82-84 BONNEVILLE RWD, FIREBIRD, GRAND PRIX, PARISIENNE
PT587	DODGE	97-06 RAM 3500 2WD; 99-06 RAM 2500 2WD; 03-04 RAM 2500 4WD
PT588	CHEVROLET	01-06 SILVERADO 2500HD/3500
	DODGE	04-06 RAM 2500/3500 2WD; 05-06 RAM 2500/3500 4WWD
	FORD	99-06 F450/550 SUPER DUTY
	GMC	01-06 SIERRA 2500HD/3500
PT58WB	HD TRUCKS	CASE; JOHN DEERE; INTERNATIONAL HARVESTER
PT58WB1	HD TRUCKS	GM; MACK
PT58WB2	CONVERSION	58WB ROCKWELL/6.5C BW TO 58WB ROCKWELL/6.5C BW. PT 58WB TO PT58WB1
PT6100	HD TRUCKS	ALLIS-CHALMERS; AUSTIN-WESTERN; CASE; EUCLID; GALION; HYSTER; INTL HARVESTER TEREX; WABCO; OFF-HIGHWAY EQUIP
PT6101	HD TRUCKS	ALLIS-CHALMERS; AUSTIN-WESTERN; CASE; EUCLID; GALION; HYSTER; INTL HARVESTER TEREX; WABCO; OFF-HIGHWAY EQUIP
PT6102	CONVERSION	6BL BW/62N ROCKWELL TO 6C BW/62N ROCKWELL. PT6106 TO PT6100
PT6106	HD TRUCKS	ALLIS-CHALMERS; CASE; CATERPILLAR; CLARK; CHAMPION; JOHN-DEERE; EATON; EUCLID FIAT-ALLIS; INT'L HARVESTER; KOMATSU; MASSEY-FERGUSON; TEREX
PT6109	HD TRUCKS	FORD

APPLICATION LISTING BY PART NUMBER

PART NO. MAKE MODEL

PT675	FORD	70 FAIRLANE, FALCON; 78 FAIRMONT; 70-74 COUNTRY SEDAN, GALAXIE; 70-76 TORINO
		70-76 COUNTRY SQUIRE; 70-77 CUSTOM 500, MAVERICK; 70-78 LTD, MUSTANG; 71-79 PINTO
		72-76 GRAN TORINO; 74-78 E100/150 2WD; 75-80 GRANADA; 86-89 AEROSTAR FWD
		88-89 RANGER 2WD
	MERCURY	70-73, 75-76 COUGAR; 70-76 MONTEGO; 71-77 COMET; 75-79 BOBCAT; 75-80 MONARCH
		77-78 GR. MARQUIS, MARQUIS
PT6N8	HD TRUCKS	CHEVY/GMC; FORD; FREIGHTLINER; INTERNATIONAL; NAVISTAR; KENWORTH; MACK;
		PETERBILT; STERLING; VOLVO; WESTERN-STAR
PT7100	HD TRUCKS	AUSTIN-WESTERN; CASE; CLARK; EATON; EUCLID; FIAT-ALLIS; FORD; INTL' HARVESTER
		TEREX; WABCO; OFF-HIGHWAY EQUIP; OSH-KOSH; VOLVO
PT7102	HD TRUCKS	AUSTIN-WESTERN; CASE; CATERFILLAR; CLARK; EATON; EUCLID; FIAT-ALLIS; FORD
		INT'L HARVESTER; TEREX; WABCO; OFF-HIGHWAY EQUIP
PT7105	HD TRUCKS	ALLIS-CHALMERS; AUSTIN-WESTERN; CASE; CATERPILLAR; CLARK; JOHN DEERE; EATON
		FIAT-ALLIS; INT'L HARVESTER; KOMATSU; MASSEY-FERGUSON; STEIGER; TEREX; VOLVO
PT8105	HD TRUCKS	CASE; CATERPILLAR; CHAMPION; JOHN DEERE; EATON; FIAT-ALLIS; INT'L HARVESTER
		KOMATSU; STEIGER
PT8200	HD TRUCKS	CHAMPION; CLARK; JOHN DEERE; EATON; EUCLID; FIAT-ALLIS; HYSTER; INT'L HARVESTER
		TEREX; WABCO; FORD; MACK; WHITE; WAGNER; OFF HIGHWAY EQUIP
PT8201	CONVERSION	8C BW TO 82N ROCKWELL. PT 8203 TO PT8200
PT8202	CONVERSION	8C BW TO 82N ROCKWELL. PT 8105 TO PT8200
PT8203	HD TRUCKS	IDUSTRIAL EQUIPMENT
PT8500	HD TRUCKS	CATERPILLAR; FIAT-ALLIS
PT8502	HD TRUCKS	CASE; CATERPILLAR; CHAMPION; CLARK; JOHN DEERE; EATON; FIAT-ALLIS;
		INT'L HARVESTER; KOMATSU
PT9014	HD TRUCKS	CURTISS-WRIGHT; EUCLID; FIAT-ALLIS; INT'L HARVESTER; TEREX
PT9017	CONVERSION	1820 SPICER/TD J310 TO 9C BW/92N ROCKWELL. PT9031 TO PT9014
PT9031	HD TRUCKS	CATERPILLAR; CLARK; JOHN DEERE; EATON; EUCLID; FIAT-ALLIS; FURUKAWA
		INT'L HARVESTER; KOMATSU; MACK; MICHIGAN; TEREX; WABCO
PTL90	HD TRUCKS	CHEVY/GMC; FORD; FREIGHTLINER; INTERNATIONAL; NAVISTAR; KENWORTH; MACK
		PETERBILT; STERLING; VOLVO; WESTERN-STAR
PTL170	HD TRUCKS	CHEVY/GMC; FORD; FREIGHTLINER; INTERNATIONAL; NAVISTAR; KENWORTH; MACK
		PETERBILT; STERLING; VOLVO; WESTERN-STAR
PTL250	HD TRUCKS	CHEVY/GMC; FORD; FREIGHTLINER; INTERNATIONAL; NAVISTAR; KENWORTH; MACK
		PETERBILT; STERLING; VOLVO; WESTERN-STAR

QUICK REFERENCE GUIDE

BY PART NUMBER

PTC PART #	BORE DIAMETER	KEYWAY	YOKE LENGTH	DESCRIPTION	
PT 10-3-12	3/4"	n/a	5-1/2"	SQUARE	SLIP YOKE
PT 10-3-121	1-1/4"	n/a	5-1/2"	16-SPLINE	SLIP YOKE
PT 10-3-122	1"	n/a	5-1/2"	SQUARE	SLIP YOKE
PT 10-3-13	3/4"	n/a	5-1/2"	STRAIGHT RND	SLIP YOKE
PT 10-3-131	1"	n/a	5-1/2"	6-SPLINE	SLIP YOKE
PT 10-3-162	7/8"	n/a	5-1/2"	HEXAGON	SLIP YOKE
PT 10-3-163	1-1/4"	n/a	5-1/2"	STRAIGHT RND	SLIP YOKE
PT 10-3-18	1-1/4"	n/a	5-1/2"	16-SPLINE	SLIP YOKE
PT 10-3-183	1-1/8"	n/a	5-1/2"	STRAIGHT RND	SLIP YOKE
PT 10-3-203	15/16"	n/a	5-1/2"	STRAIGHT RND	SLIP YOKE
PT 10-3-22	7/8"	n/a	5-1/2"	SQUARE	SLIP YOKE
PT 10-3-23	13/16"	n/a	5-1/2"	STRAIGHT RND	SLIP YOKE
PT 10-3-291	1-5/32"	n/a	5-1/2"	26-SPLINE	SLIP YOKE
PT 10-3-32	1-1/8"	n/a	5-1/2"	HEXAGON	SLIP YOKE
PT 10-3-33	7/8"	n/a	5-1/2"	STRAIGHT RND	SLIP YOKE
PT 10-3-51	1-1/4"	n/a	5-1/2"	6-SPLINE	SLIP YOKE
PT 10-3-81	1-1/8"	n/a	5-1/2"	10-SPLINE	SLIP YOKE
PT 10-3-83	1"	n/a	5-1/2"	STRAIGHT RND	SLIP YOKE
PT 10-4-101	1"	n/a	2-1/2"	6-SPLINE	END YOKE
PT 10-4-103	1-1/8"	1/4"	2-1/2"	STRAIGHT RND	END YOKE
PT 10-4-1043	7/8"	1/4"	2-1/2"	STRAIGHT RND	END YOKE
PT 10-4-11	1-1/8"	n/a	2-1/2"	6-SPLINE	END YOKE
PT 10-4-113	1-1/8"	5/16"	2-1/2"	STRAIGHT RND	END YOKE
PT 10-4-12	7/8"	n/a	2-1/2"	SQUARE	END YOKE
PT 10-4-123	1-1/4"	5/16"	2-1/2"	STRAIGHT RND	END YOKE
PT 10-4-13	3/4"	3/16"	2-1/2"	STRAIGHT RND	END YOKE
PT 10-4-133	3/4"	3/16"	2-1/2"	STRAIGHT RND	END YOKE
PT 10-4-143	1-1/8"	1/4"	2-1/2"	STRAIGHT RND	END YOKE
PT 10-4-1473	1-1/8"	5/16"	2-1/2"	STRAIGHT RND	END YOKE
PT 10-4-153	1-3/16"	5/16"	2-1/2"	STRAIGHT RND	END YOKE
PT 10-4-163	1-1/16"	1/4"	2-1/2"	STRAIGHT RND	END YOKE
PT 10-4-173	13/16"	1/4"	2-1/2"	STRAIGHT RND	END YOKE
PT 10-4-183	1-1/4"	1/4"	2-1/2"	STRAIGHT RND	END YOKE
PT 10-4-193	1-1/4"	5/16"	2-1/2"	STRAIGHT RND	END YOKE
PT 10-4-203	7/8"	n/a	2-1/2"	STRAIGHT RND	END YOKE
PT 10-4-21	1-1/4"	n/a	2-1/2"	6-SPLINE	END YOKE
PT 10-4-213	1-3/8"	3/8"	2-1/2"	STRAIGHT RND	END YOKE
PT 10-4-22	3/4"	n/a	2-1/2"	SQUARE	END YOKE
PT 10-4-223	1-1/2"	3/8"	2-1/2"	STRAIGHT RND	END YOKE
PT 10-4-23	3/4"	1/4"	2-1/2"	STRAIGHT RND	END YOKE
PT 10-4-253	7/8"	1/4"	2-1/2"	STRAIGHT RND	END YOKE
PT 10-4-282	7/8"	n/a	2-1/2"	HEXAGON	END YOKE
PT 10-4-293	1-3/8"	5/16"	2-1/2"	STRAIGHT RND	END YOKE
PT 10-4-303	3/4"	n/a	2-1/2"	STRAIGHT RND	END YOKE
PT 10-4-31	1-3/8"	n/a	2-1/2"	6-SPLINE	END YOKE
PT 10-4-32	1-1/8"	n/a	2-1/2"	HEXAGON	END YOKE
PT 10-4-33	13/16"	3/16"	2-1/2"	STRAIGHT RND	END YOKE
PT 10-4-333	5/8"	n/a	2-1/2"	STRAIGHT RND	END YOKE
PT 10-4-363	1-1/4"	n/a	2-1/2"	STRAIGHT RND	END YOKE
PT 10-4-373	5/8"	3/16"	2-1/2"	STRT RND	END YOKE
PT 10-4-383	1-7/16"	3/8"	2-1/2"	STRAIGHT RND	END YOKE
PT 10-4-42	13/16"	n/a	2-1/2"	SQUARE	END YOKE
PT 10-4-43	13/16"	1/4"	2-1/2"	STRAIGHT RND	END YOKE
PT 10-4-443	1"	n/a	2-1/2"	STRAIGHT RND	END YOKE
PT 10-4-453	7/8"	1/4"	2-1/2"	STRAIGHT RND	END YOKE
PT 10-4-473	1-1/8"	n/a	2-1/2"	STRAIGHT RND	END YOKE
PT 10-4-481	7/8"	n/a	2-1/2"	13-SPLINE	END YOKE
PT 10-4-493	1"	1/4"	2-1/2"	STRAIGHT RND	END YOKE
PT 10-4-52	1"	n/a	2-1/2"	SQUARE	END YOKE
PT 10-4-53	7/8"	3/16"	2-1/2"	STRAIGHT RND	END YOKE
PT 10-4-573	1"	1/4"	2-1/2"	STRAIGHT RND	END YOKE
PT 10-4-62	7/8"	n/a	2-7/8"	SQUARE	END YOKE
PT 10-4-63	7/8"	1/4"	2-1/2"	STRAIGHT RND	END YOKE
PT 10-4-641	7/8"	n/a	3-13/16"	13-SPLINE	END YOKE
PT 10-4-643	15/16"	n/a	2-1/2"	STRAIGHT RND	END YOKE
PT 10-4-683	15/16"	1/4"	1-13/16"	STRAIGHT RND	END YOKE
PT 10-4-693	3/4"	3/16"	1-13/16"	STRAIGHT RND	END YOKE
PT 10-4-703	7/8"	1/4"	1-13/16"	STRAIGHT RND	END YOKE
PT 10-4-713	13/16"	1/4"	1-13/16"	STRAIGHT RND	END YOKE
PT 10-4-723	1"	1/4"	1-13/16"	STRAIGHT RND	END YOKE
PT 10-4-73	15/16"	1/4"	2-1/2"	STRAIGHT RND	END YOKE
PT 10-4-83	1"	3/16"	2-1/2"	STRAIGHT RND	END YOKE
PT 10-4-93	1"	1/4"	2-1/2"	STRAIGHT RND	END YOKE
PT 10-4-943	7/8"	3/16"	2-1/2"	STRAIGHT RND	END YOKE

QUICK REFERENCE GUIDE

BY BORE DIAMETER

BORE DIAMETER	KEYWAY	YOKE LENGTH	DESCRIPTION	PTC PART #
5/8"	3/16"	2-1/2"	STRAIGHT RND END YOKE	PT 10-4-373
5/8"	n/a	2-1/2"	STRAIGHT RND END YOKE	PT 10-4-333
3/4"	n/a	2-1/2"	SQUARE END YOKE	PT 10-4-22
3/4"	3/16"	1-13/16"	STRAIGHT RND END YOKE	PT 10-4-693
3/4"	3/16"	2-1/2"	STRAIGHT RND END YOKE	PT 10-4-13
3/4"	3/16"	2-1/2"	STRAIGHT RND END YOKE	PT 10-4-133
3/4"	1/4"	2-1/2"	STRAIGHT RND END YOKE	PT 10-4-23
3/4"	n/a	2-1/2"	STRAIGHT RND END YOKE	PT 10-4-303
3/4"	n/a	5-1/2"	SQUARE SLIP YOKE	PT 10-3-12
3/4"	n/a	5-1/2"	STRAIGHT RND SLIP YOKE	PT 10-3-13
13/16"	n/a	2-1/2"	SQUARE END YOKE	PT 10-4-42
13/16"	3/16"	2-1/2"	STRAIGHT RND END YOKE	PT 10-4-33
13/16"	1/4"	2-1/2"	STRAIGHT RND END YOKE	PT 10-4-173
13/16"	1/4"	2-1/2"	STRAIGHT RND END YOKE	PT 10-4-43
13/16"	1/4"	1-13/16"	STRAIGHT RND END YOKE	PT 10-4-713
13/16"	n/a	5-1/2"	STRAIGHT RND SLIP YOKE	PT 10-3-23
7/8"	n/a	2-1/2"	13-SPLINE END YOKE	PT 10-4-481
7/8"	n/a	3-13/16"	13-SPLINE END YOKE	PT 10-4-641
7/8"	n/a	2-1/2"	SQUARE END YOKE	PT 10-4-12
7/8"	n/a	2-7/8"	SQUARE END YOKE	PT 10-4-62
7/8"	n/a	2-1/2"	HEXAGON END YOKE	PT 10-4-282
7/8"	1/4"	2-1/2"	STRAIGHT RND END YOKE	PT 10-4-1043
7/8"	n/a	2-1/2"	STRAIGHT RND END YOKE	PT 10-4-203
7/8"	1/4"	2-1/2"	STRAIGHT RND END YOKE	PT 10-4-253
7/8"	3/16"	2-1/2"	STRAIGHT RND END YOKE	PT 10-4-53
7/8"	1/4"	2-1/2"	STRAIGHT RND END YOKE	PT 10-4-63
7/8"	1/4"	2-1/2"	STRAIGHT RND END YOKE	PT 10-4-453
7/8"	3/16"	2-1/2"	STRAIGHT RND END YOKE	PT 10-4-943
7/8"	1/4"	1-13/16"	STRAIGHT RND END YOKE	PT 10-4-703
7/8"	n/a	5-1/2"	HEXAGON SLIP YOKE	PT 10-3-162
7/8"	n/a	5-1/2"	SQUARE SLIP YOKE	PT 10-3-22
7/8"	n/a	5-1/2"	STRAIGHT RND SLIP YOKE	PT 10-3-33
15/16"	n/a	2-1/2"	STRAIGHT RND END YOKE	PT 10-4-643
15/16"	1/4"	1-13/16"	STRAIGHT RND END YOKE	PT 10-4-683
15/16"	1/4"	2-1/2"	STRAIGHT RND END YOKE	PT 10-4-73
15/16"	n/a	5-1/2"	STRAIGHT RND SLIP YOKE	PT 10-3-203
1"	n/a	2-1/2"	6-SPLINE END YOKE	PT 10-4-101
1"	n/a	2-1/2"	SQUARE END YOKE	PT 10-4-52
1"	1/4"	2-1/2"	STRAIGHT RND END YOKE	PT 10-4-493
1"	1/4"	2-1/2"	STRAIGHT RND END YOKE	PT 10-4-573
1"	n/a	2-1/2"	STRAIGHT RND END YOKE	PT 10-4-443
1"	1/4"	1-13/16"	STRAIGHT RND END YOKE	PT 10-4-723
1"	3/16"	2-1/2"	STRAIGHT RND END YOKE	PT 10-4-83
1"	1/4"	2-1/2"	STRAIGHT RND END YOKE	PT 10-4-93
1"	n/a	5-1/2"	SQUARE SLIP YOKE	PT 10-3-122
1"	n/a	5-1/2"	6-SPLINE SLIP YOKE	PT 10-3-131
1"	n/a	5-1/2"	STRAIGHT RND SLIP YOKE	PT 10-3-83
1-1/16"	1/4"	2-1/2"	STRAIGHT RND END YOKE	PT 10-4-163
1-1/8"	n/a	2-1/2"	6-SPLINE END YOKE	PT 10-4-11
1-1/8"	n/a	2-1/2"	HEXAGON END YOKE	PT 10-4-32
1-1/8"	5/16"	2-1/2"	STRAIGHT RND END YOKE	PT 10-4-113
1-1/8"	1/4"	2-1/2"	STRAIGHT RND END YOKE	PT 10-4-103
1-1/8"	1/4"	2-1/2"	STRAIGHT RND END YOKE	PT 10-4-143
1-1/8"	5/16"	2-1/2"	STRAIGHT RND END YOKE	PT 10-4-1473
1-1/8"	n/a	2-1/2"	STRAIGHT RND END YOKE	PT 10-4-473
1-1/8"	n/a	5-1/2"	HEXAGON SLIP YOKE	PT 10-3-32
1-1/8"	n/a	5-1/2"	10-SPLINE SLIP YOKE	PT 10-3-81
1-1/8"	n/a	5-1/2"	STRAIGHT RND SLIP YOKE	PT 10-3-183
1-5/32"	n/a	5-1/2"	26-SPLINE SLIP YOKE	PT 10-3-291
1-3/16"	5/16"	2-1/2"	STRAIGHT RND END YOKE	PT 10-4-153
1-1/4"	n/a	2-1/2"	6-SPLINE END YOKE	PT 10-4-21
1-1/4"	5/16"	2-1/2"	STRAIGHT RND END YOKE	PT 10-4-123
1-1/4"	1/4"	2-1/2"	STRAIGHT RND END YOKE	PT 10-4-183
1-1/4"	5/16"	2-1/2"	STRAIGHT RND END YOKE	PT 10-4-193
1-1/4"	n/a	2-1/2"	STRAIGHT RND END YOKE	PT 10-4-363
1-1/4"	n/a	5-1/2"	16-SPLINE SLIP YOKE	PT 10-3-18
1-1/4"	n/a	5-1/2"	6-SPLINE SLIP YOKE	PT 10-3-51
1-1/4"	n/a	5-1/2"	16-SPLINE SLIP YOKE	PT 10-3-121
1-1/4"	n/a	5-1/2"	STRAIGHT RND SLIP YOKE	PT 10-3-163
1-3/8"	n/a	2-1/2"	6-SPLINE END YOKE	PT 10-4-31
1-3/8"	3/8"	2-1/2"	STRAIGHT RND END YOKE	PT 10-4-213
1-3/8"	5/16"	2-1/2"	STRAIGHT RND END YOKE	PT 10-4-293
1-7/16"	3/8"	2-1/2"	STRAIGHT RND END YOKE	PT 10-4-383
1-1/2"	3/8"	2-1/2"	STRAIGHT RND END YOKE	PT 10-4-223

1000 SERIES END YOKES

USE U-JOINT PT570
(A = 1.500 B = .938)

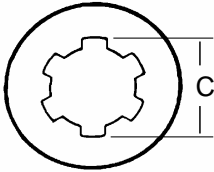
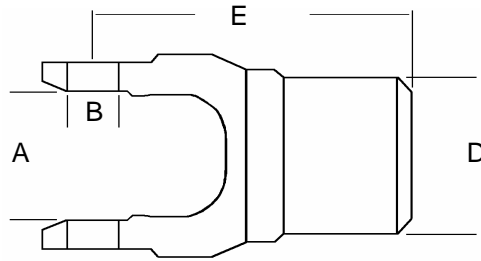

SPLINE BORE

PTC PART #	(C) BORE DIAM.	(D) GROUND HUB DIAM.	SPLINE WIDTH	HOLE DIAM.	set screw		(E) LENGTH
					LOCATION	DISTANCE TO END	
PT 10-4-481	7/8" - 13 spl .875-13 spl	1-5/8" 1.625	3/32" 0.094	3/8" 0.375	6 - 12	5/8" 0.625	2-1/2" 2.500
PT 10-4-641	7/8" - 13 spl .875-13 spl	1-1/2" 1.500	3/32" 0.094	1/4" 0.250	6 - 12	7/16" 0.438	3-13/16" 3.812
PT 10-4-101	1" - 6 spl 1.000-6 spl	1-5/8" 1.625	1/4" 0.250	3/8" 0.375	3 - 9	5/8" 0.625	2-1/2" 2.500
PT 10-4-11	1-1/8" - 6 spl 1.125-6 spl	1-5/8" 1.625	9/32" 0.281	n/a	thru hub	7/16" 0.438	2-1/2" 2.500
PT 10-4-21	1-1/4" - 6 spl 1.250-6 spl	1-5/8" 1.625	5/16" 0.312	n/a	thru hub	7/16" 0.438	2-1/2" 2.500
PT 10-4-31	1-3/8" - 6 spl 1.375-6 spl	2" 2.000	11/32" 0.344	n/a	thru hub	7/16" 0.438	2-1/2" 2.500

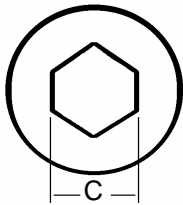

HEX BORE

PTC PART #	(C) BORE DIAM.	(D) GROUND HUB DIAM.	HOLE DIAM.	set screw		(E) LENGTH
				LOCATION	DISTANCE TO END	
PT 10-4-282	7/8" 0.875	2" 2.000	3/8" 0.375	3 - 9	5/8" 0.625	2-1/2" 2.500
PT 10-4-32	1-1/8" 1.125	2" 2.000	3/8" 0.375	3 - 9	5/8" 0.625	2-1/2" 2.500

1000 SERIES END YOKES

USE U-JOINT PT570
(A = 1.500 B = .938)

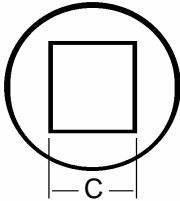
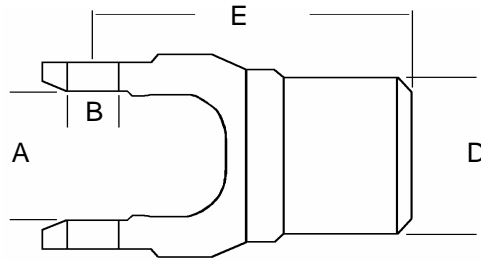

SQUARE BORE

PTC PART #	(C) BORE DIAM.	(D)		set screw LOCATION	DISTANCE TO END	(E) LENGTH
		GROUND HUB DIAM.	HOLE DIAM.			
PT 10-4-22	3/4" 0.750	1-5/8" 1.625	3/8" 0.375	3 - 9	5/8" 0.625	2-1/2" 2.500
PT 10-4-42	13/16" 0.812	1-31/32" 1.969	3/8" 0.375	3 - 9	5/8" 0.625	2-1/2" 2.500
PT 10-4-12	7/8" 0.875	1-31/32" 1.969	3/8" 0.375	3 - 9	5/8" 0.625	2-1/2" 2.500
PT 10-4-62	7/8" 0.875	1-5/8" 1.625	3/8" 0.375	3 - 9	5/8" 0.625	2-7/8" 2.875
PT 10-4-52	1" 1.000	2" 2.000	3/8" 0.375	3 - 9	5/8" 0.625	2-1/2" 2.500

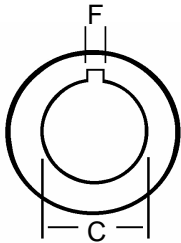

STRAIGHT ROUND BORE

PTC PART #	(C) BORE DIAM.	(F) KEYWAY WIDTH	HOLE DIAM.	set screw LOCATION	DISTANCE TO END	(E) LENGTH	GROUND HUB DIAM.
PT 10-4-333	5/8" 0.625	n/a	n/a	n/a	n/a	2-1/2" 2.500	1-5/8" 1.625

1000 SERIES END YOKES

USE U-JOINT PT570
(A = 1.500 B = .938)

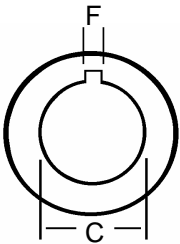
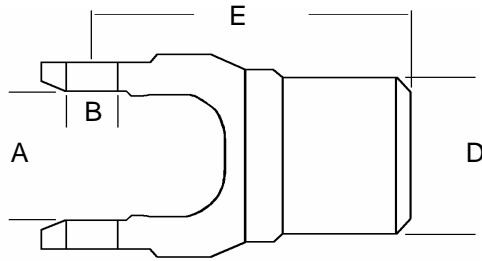

STRAIGHT ROUND BORE

PTC PART #	(C) BORE DIAM.	(F) KEYWAY WIDTH	HOLE DIAM.	set screw		(E) LENGTH	GROUND HUB DIAM.
				LOCATION	DISTANCE TO END		
PT 10-4-693	3/4" 0.750	3/16" 0.188	3/8" 0.375	9	9/16" 0.562	1-13/16" 1.812	n/a
PT 10-4-13	3/4" 0.750	3/16" 0.188	3/8" 0.375	6	5/8" 0.625	2-1/2" 2.500	1-5/8" 1.625
PT 10-4-133	3/4" 0.750	3/16" 0.188	3/8" 0.375	3 - 9	5/8" 0.625	2-1/2" 2.500	1-5/8" 1.625
PT 10-4-23	3/4" 0.750	1/4" 0.250	3/8" 0.375	6	5/8" 0.625	2-1/2" 2.500	1-5/8" 1.625
PT 10-4-303	3/4" 0.750	n/a	n/a	n/a	n/a	2-1/2" 2.500	1-5/8" 1.625
PT 10-4-33	13/16" 0.812	3/16" 0.188	3/8" 0.375	6	5/8" 0.625	2-1/2" 2.500	1-5/8" 1.625
PT 10-4-173	13/16" 0.812	1/4" 0.250	3/8" 0.375	9	5/8" 0.625	2-1/2" 2.500	1-5/8" 1.625
PT 10-4-43	13/16" 0.812	1/4" 0.250	3/8" 0.375	6	5/8" 0.625	2-1/2" 2.500	1-5/8" 1.625
PT 10-4-713	13/16" 0.812	1/4" 0.250	3/8" 0.375	9	9/16" 0.562	1-13/16" 1.812	n/a
PT 10-4-1043	7/8" 0.875	1/4" 0.250	3/8" 0.375	6	5/8" 0.625	5-1/2" 5.500	1-1/2"
PT 10-4-203	7/8" 0.875	n/a	7/16" - 20 .438-20	3 - 9	1/2" 0.500	2-1/2" 2.500	1-5/8" 1.625
PT 10-4-253	7/8" 0.875	1/4" 0.250	3/8" 0.375	3 - 9	5/8" 0.625	2-1/2" 2.500	1-5/8" 1.625

1000 SERIES END YOKES

USE U-JOINT PT570
(A = 1.500 B = .938)

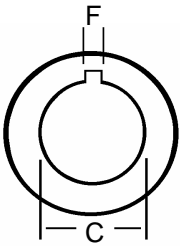
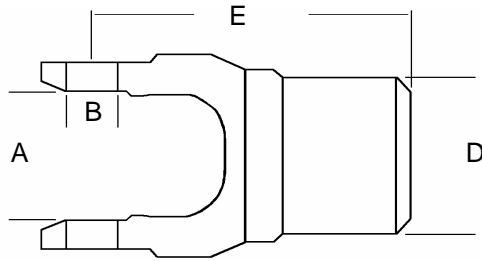

STRAIGHT ROUND BORE

PTC PART #	(C) BORE DIAM.	(F) KEYWAY WIDTH	HOLE DIAM.	set screw		(E) LENGTH	GROUND HUB DIAM.
				LOCATION	DISTANCE TO END		
PT 10-4-53	7/8" 0.875	3/16" 0.188	3/8" 0.375	6	5/8" 0.625	2-1/2" 2.500	1-5/8" 1.625
PT 10-4-63	7/8" 0.875	1/4" 0.250	3/8" 0.375	6	5/8" 0.625	2-1/2" 2.500	1-5/8" 1.625
PT 10-4-453	7/8" 0.875	1/4" 0.250	3/8" 0.375	9	5/8" 0.625	2-1/2" 2.500	1-5/8" 1.625
PT 10-4-943	7/8" 0.875	3/16" 0.188	3/8" 0.375	6	7/16" 0.438	2-1/2" 2.500	1-5/8" 1.625
PT 10-4-703	7/8" 0.875	1/4" 0.250	3/8" 0.375	9	9/16" 0.562	1-13/16" 1.812	n/a
PT 10-4-643	15/16" 0.938	n/a	.302" drill hole	tnru hub	1/2" 0.500	2-1/2" 2.500	1-5/8" 1.625
PT 10-4-683	15/16" 0.938	1/4" 0.250	3/8" 0.375	9	9/16" 0.562	1-13/16" 1.812	n/a
PT 10-4-73	15/16" 0.938	1/4" 0.250	3/8" 0.375	6	5/8" 0.625	2-1/2" 2.500	1-5/8" 1.625
PT 10-4-493	1" 1.000	1/4" 0.250	3/8" 0.375	12	5/8" 0.625	2-1/2" 2.500	1-5/8" 1.625
PT 10-4-573	1" 1.000	1/4" 0.250	3/8" 0.375	9	5/8" 0.625	2-1/2" 2.500	1-5/8" 1.625
PT 10-4-443	1" 1.000	n/a	3/8" - drill .375-drill	tnru hub	5/8" 0.625	2-1/2" 2.500	1-5/8" 1.625
PT 10-4-723	1" 1.000	1/4" 0.250	3/8" 0.375	9	9/16" 0.562	1-13/16" 1.812	n/a

1000 SERIES END YOKES

USE U-JOINT PT570
(A = 1.500 B = .938)

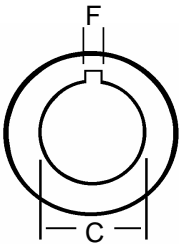
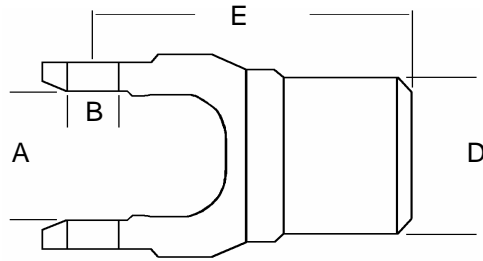

STRAIGHT ROUND BORE

PTC PART #	(C) BORE DIAM.	(F) KEYWAY WIDTH	HOLE DIAM.	set screw		(E) LENGTH	GROUND HUB DIAM.
				LOCATION	DISTANCE TO END		
PT 10-4-83	1" 1.000	3/16" 0.188	3/8" 0.375	6	5/8" 0.625	2-1/2" 2.500	1-5/8" 1.625
PT 10-4-93	1" 1.000	1/4" 0.250	3/8" 0.375	6	5/8" 0.625	2-1/2" 2.500	2" 2.000
PT 10-4-163	1-1/16" 1.062	1/4" 0.250	3/8" 0.375	9	5/8" 0.625	2-1/2" 2.500	2" 2.000
PT 10-4-113	1-1/8" 1.125	5/16" 0.312	3/8" 0.375	6	5/8" 0.625	2-1/2" 2.500	2" 2.000
PT 10-4-103	1-1/8" 1.125	1/4" 0.250	3/8" 0.375	6	5/8" 0.625	2-1/2" 2.500	2" 2.000
PT 10-4-143	1-1/8" 1.125	1/4" 0.250	3/8" 0.375	9	5/8" 0.625	2-1/2" 2.500	2" 2.000
PT 10-4-1473	1-1/8" 1.125	5/16" 0.312	3/8" 0.375	9	5/8" 0.625	2-1/2" 2.500	2" 2.000
PT 10-4-473	1-1/8" 1.125	n/a	3/8" - drill .375-drill	tnru hub	5/8" 0.625	2-1/2" 2.500	2" 2.000
PT 10-4-153	1-3/16" 1.188	5/16" 0.312	3/8" 0.375	6	5/8" 0.625	2-1/2" 2.500	2" 2.000
PT 10-4-123	1-1/4" 1.250	5/16" 0.312	3/8" 0.375	6	5/8" 0.625	2-1/2" 2.500	2" 2.000
PT 10-4-183	1-1/4" 1.250	1/4" 0.250	3/8" 0.375	9	5/8" 0.625	2-1/2" 2.500	2" 2.000
PT 10-4-193	1-1/4" 1.250	5/16" 0.312	3/8" 0.375	9	5/8" 0.625	2-1/2" 2.500	2" 2.000

1000 SERIES END YOKES

USE U-JOINT PT570
 (A = 1.500 B = .938)

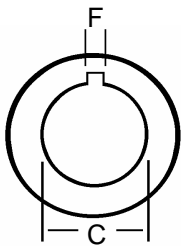
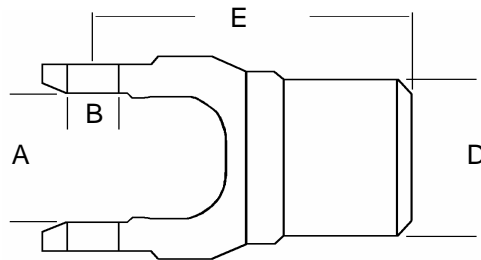

STRAIGHT ROUND BORE

PTC PART #	(C) BORE DIAM.	(F) KEYWAY WIDTH	HOLE DIAM.	set screw		(E) LENGTH	GROUND HUB DIAM.
				LOCATION	DISTANCE TO END		
PT 10-4-363	1-1/4" 1.250	n/a	3/8" - drill .375-drill	tnru hub	5/8" 0.625	2-1/2" 2.500	n/a
PT 10-4-213	1-3/8" 1.375	3/8" 0.375	3/8" 0.375	6	5/8" 0.625	2-1/2" 2.500	2-1/4" 2.250
PT 10-4-293	1-3/8" 1.375	5/16" 0.312	3/8" 0.375	6	5/8" 0.625	2-1/2" 2.500	n/a
PT 10-4-383	1-7/16" 1.438	3/8" 0.375	3/8" 0.375	6	5/8" 0.625	2-1/2" 2.500	2-1/4" 2.250
PT 10-4-223	1-1/2" 1.500	3/8" 0.375	3/8" 0.375	6	5/8" 0.625	2-1/2" 2.500	2-1/4" 2.250

1000 SERIES SLIP YOKES

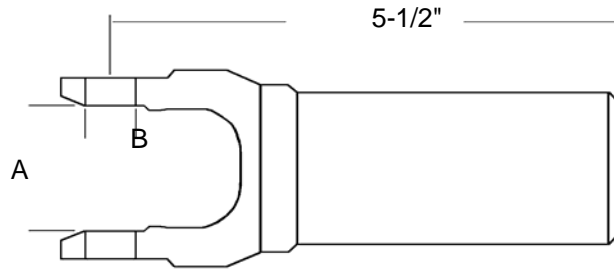

USE PTC U-JOINT PT570 (A = 1.500 B = .938)

HEX BORE

PTC PART #	(C) BORE DIAM.	HOLE DIAM.	grease fitting	
			LOCATION	DISTANCE TO END
PT 10-3-162	7/8" 0.875	1/4" - 28 .250-28	3	1-3/4" 1.750
PT 10-3-32	1-1/8" 1.125	1/4" - 28 .250-28	3	1-3/4" 1.750

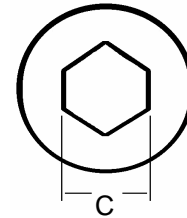

SQUARE BORE

PTC PART #	(C) BORE DIAM.	HOLE DIAM.	grease fitting	
			LOCATION	DISTANCE TO END
PT 10-3-12	3/4" 0.750	1/4" - 28 .250-28	3	1-3/4" 1.750
PT 10-3-22	7/8" 0.875	1/4" - 28 .250-28	3	1-3/4" 1.750
PT 10-3-122	1" 1.000	1/4" - 28 .250-28	3	1-3/4" 1.750

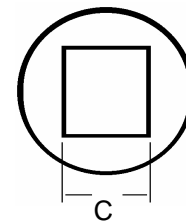

STRAIGHT ROUND BORE

PTC PART #	(C) BORE DIAM.	KEYWAY WIDTH	set screw		DISTANCE TO END
			HOLE DIAM.	LOC.	
PT 10-3-13	3/4" 0.750	3/16" 0.188	1/4" - 28 .250-28	3	1-3/4" 1.750
PT 10-3-23	13/16" 0.812	1/4" 0.250	1/4" - 28 .250-28	3	1-3/4" 1.750
PT 10-3-33	7/8" 0.875	1/4" 0.250	1/4" - 28 .250-28	3	1-3/4" 1.750

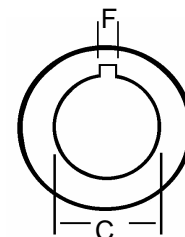

1000 SERIES SLIP YOKES

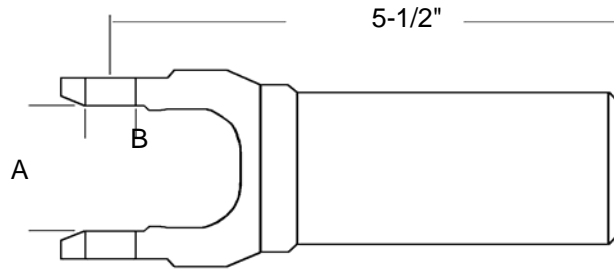

USE PTC U-JOINT PT570 (A = 1.500 B = .938)

STRAIGHT ROUND BORE

PTC PART #	(C) BORE DIAM.	KEYWAY WIDTH	set screw		
			HOLE DIAM.	LOC.	DISTANCE TO END
PT 10-3-203	15/16" 0.938	1/4" 0.250	1/4" - 28 .250-28	3	1-3/4" 1.750
PT 10-3-83	1" 1.000	1/4" 0.250	1/4" - 28 .250-28	3	1-3/4" 1.750
PT 10-3-183	1-1/8" 1.125	5/16" 0.312	1/4" - 28 .250-28	3	1-3/4" 1.750
PT 10-3-163	1-1/4" 1.250	5/16" 0.312	1/4" - 28 .250-28	3	1-3/4" 1.750

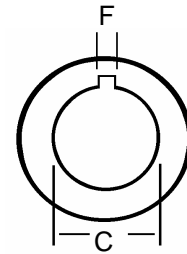

SPLINE BORE

PTC PART #	(C) BORE DIAM.	SPLINE WIDTH	HOLE DIAM.	grease fitting	
				LOCATION	DISTANCE TO END
PT 10-3-131	1" - 6 spl 1.000-6 spl	1/4" 0.250	1/4" - 28 .250-28	3	1-3/4" 1.750
PT 10-3-81	1-1/8" - 10 spl 1.125-10 spl	11/64" 0.174	1/4" - 28 .250-28	3	1-3/4" 1.750
PT 10-3-291	1-5/32" - 26 spl 1.156-26 spl	5/64" 0.078	1/4" - 28 .250-28	3	3-5/8" 3.625
PT 10-3-51	1-1/4" - 6 spl 1.250-6spl	5/16" 0.312	1/4" - 28 .250-28	3	1-3/4" 1.750
PT 10-3-121	1-1/4" - 16 spl 1.250-16 spl	1/8" 0.125	1/4" - 28 .250-28	3	15/16" 0.938
PT 10-3-18	1-1/4" - 16 spl 1.250-16 spl	1/8" 0.125	1/4" - 28 .250-28	3	3-5/8" 3.625

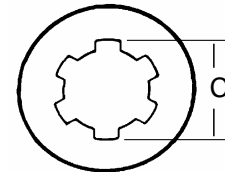

DOMESTIC CENTER BEARING APPLICATIONS

Model	Year		PTC #
<u>AUTOCAR</u>			
HEAVY DUTY	61-90	SPICER 1410, 1480 SERIES Bearing Diameter = 1.575"	PT HB88508E
		SPICER 1550 - 1650 SERIES Bearing Diameter = 1.772"	PT HB88509A
		SPICER 1700, 1710 SERIES Bearing Diameter = 1.969"	PT HB88510
		SPICER 1760 - 1850 SERIES & ROCKWELL 88WB SERIES Bearing Diameter = 2.362"	PT HB88512A
<u>CHECKER</u>			
ALL MODELS	50-82	SPICER 1280 - 1410 SERIES Bearing Diameter = 1.378"	PT HB88107B
<u>CHEVEROLET / GMC</u>			
PASSENGER	58-64	SPICER 1280 - 1310 SERIES Bearing Diameter = 1.187"	PT HB206FF
1/2 TON TRUCKS	55-94	SPICER 1280 - 1410 SERIES Bearing Diameter = 1.378"	PT HB88107E
		SPICER 1280 & 1310 SERIES Bearing Diameter = 1.187"	PT HB206FF
1/2 TON CLASS 4 & 5	55-95	SPICER 1330 - 1480 SERIES Bearing Diameter = 1.575"	PT HB88508C
		SPICER 1410 SERIES Bearing Diameter = 1.378"	PT HB88107E
		SPICER 1410, 1480 & CLEVELAND O55 SERIES Bearing Diameter = 1.575"	PT HB88508AB
		SPICER 1480 SERIES Bearing Diameter = 1.575"	PT HB88508AA
		SPICER 1480 SERIES Bearing Diameter = 1.575"	PT HB88508D
		SPICER 1710 & ROCKWELL 68WB SERIES Bearing Diameter = 1.969"	PT HB88510
		SPICER 1760, 1710HD & 1810HD SERIES Bearing Diameter = 2.362"	PT HB88512A
3/4 TON TRUCKS	55-94	SPICER 1280 - 1410 SERIES Bearing Diameter = 1.378"	PT HB88107E
1 TON TRUCKS	55-95	SPICER 1280 - 1410 SERIES Bearing Diameter = 1.378"	PT HB88107D
		SPICER 1280 - 1410 SERIES Bearing Diameter = 1.378"	PT HB88107E
		SPICER 1330 - 1480 SERIES Bearing Diameter = 1.575"	PT HB88508AA
		SPICER 1410 SERIES Bearing Diameter = 1.575"	PT HB88508AB
2 TON CLASS 6 & 7	55-95	SPICER 1330 - 1480 SERIES Bearing Diameter = 1.575"	PT HB88508C
		SPICER 1410 SERIES Bearing Diameter = 1.378"	PT HB88107E
		SPICER 1410 SERIES Bearing Diameter = 1.575"	PT HB88508A

DOMESTIC CENTER BEARING APPLICATIONS

Model	Year		PTC #
<u>CHEVEROLET / GMC</u>			
2 TON CLASS 6 & 7	55-95	SPICER 1410 & CLEVELAND O55 SERIES	
		Bearing Diameter = 1.575"	PT HB88508AB
		SPICER 1480 SERIES	
		Bearing Diameter = 1.575"	PT HB88508AA
		SPICER 1480 SERIES	
		Bearing Diameter = 1.575"	PT HB88508D
		SPICER 1710 & ROCKWELL 68WB SERIES	
		Bearing Diameter = 1.969"	PT HB88510
		SPICER 1710HD, 1760 & 1810HD SERIES	
		Bearing Diameter = 2.362"	PT HB88512A
<u>CRANE CARRIER</u>			
HEAVY DUTY	70-92	SPICER 1500 - 1810 SERIES	
		Bearing Diameter = 1.772"	PT HB88509A
		SPICER 1700 & 1710 SERIES	
		Bearing Diameter = 1.969"	PT HB88510
		SPICER 1710HD - 1810HD SERIES	
		Bearing Diameter = 2.362"	PT HB88512A
<u>DODGE</u>			
MIDSIZE TRUCK & MINIVAN	86-97	SPICER 1280 SERIES	
		Bearing Diameter = 1.378"	PT HB88107B
1/2 TON 1500	60-95	SPICER 1280 SERIES	
		Bearing Diameter = 1.378"	PT HB88107B
		SPICER 1480 - 1550 SERIES	
		Bearing Diameter = 1.575"	PT HB88508E
		SPICER 1610 SERIES	
		Bearing Diameter = 1.772"	PT HB88509A
		SPICER 1710 SERIES	
		Bearing Diameter = 1.969"	PT HB88510
		SPICER 1810 SERIES	
		Bearing Diameter = 2.362"	PT HB88512A
3/4 TON 2500	60-95	SPICER 1280 SERIES	
		Bearing Diameter = 1.378"	PT HB88107B
		SPICER 1480 - 1550 SERIES	
		Bearing Diameter = 1.575"	PT HB88508E
		SPICER 1610 SERIES	
		Bearing Diameter = 1.772"	PT HB88509A
		SPICER 1710 SERIES	
		Bearing Diameter = 1.969"	PT HB88510
		SPICER 1810 SERIES	
		Bearing Diameter = 2.362"	PT HB88512A
1 TON 3500	60-95	SPICER 1280 SERIES	
		Bearing Diameter = 1.378"	PT HB88107B
		SPICER 1480 - 1550 SERIES	
		Bearing Diameter = 1.575"	PT HB88508E
		SPICER 1610 SERIES	
		Bearing Diameter = 1.772"	PT HB88509A
		SPICER 1710 SERIES	
		Bearing Diameter = 1.969"	PT HB88510

DOMESTIC CENTER BEARING APPLICATIONS

Model	Year	PTC #
-------	------	-------

DODGE

1 TON 3500	60-95	SPICER 1810 SERIES Bearing Diameter = 2.362"	PT HB88512A
TRUCKS CLASS 4 - UP	60-95	SPICER 1280 SERIES Bearing Diameter = 1.378"	PT HB88107B
		SPICER 1480 - 1550 SERIES Bearing Diameter = 1.575"	PT HB88508E
		SPICER 1610 SERIES Bearing Diameter = 1.772"	PT HB88509A
		SPICER 1710 SERIES Bearing Diameter = 1.969"	PT HB88510
		SPICER 1810 SERIES Bearing Diameter = 2.362"	PT HB88512A

FORD

1/2 TON F150	60-95	SPICER 1280 SERIES Bearing Diameter = 1.378"	PT HB88107A
		SPICER 1480 - 1550 SERIES Bearing Diameter = 1.575"	PT HB88508E
		SPICER 1610 SERIES Bearing Diameter = 1.772"	PT HB88509A
		SPICER 1710 SERIES Bearing Diameter = 1.969"	PT HB88510
		SPICER 1810 SERIES Bearing Diameter = 2.362"	PT HB88512A
3/4 TON F250	60-95	SPICER 1280 SERIES Bearing Diameter = 1.378"	PT HB88107A
		SPICER 1480 - 1550 SERIES Bearing Diameter = 1.575"	PT HB88508E
		SPICER 1610 SERIES Bearing Diameter = 1.772"	PT HB88509A
		SPICER 1710 SERIES Bearing Diameter = 1.969"	PT HB88510
		SPICER 1810 SERIES Bearing Diameter = 2.362"	PT HB88512A
1 TON F350 - H.D. CLASS 8	60-95	SPICER 1280 SERIES Bearing Diameter = 1.378"	PT HB88107A
		SPICER 1480 - 1550 SERIES Bearing Diameter = 1.575"	PT HB88508E
		SPICER 1610 SERIES Bearing Diameter = 1.772"	PT HB88509A
		SPICER 1710 SERIES Bearing Diameter = 1.969"	PT HB88510
		SPICER 1810 SERIES Bearing Diameter = 2.362"	PT HB88512A

FREIGHTLINER

HEAVY DUTY	60-90	SPICER 1550 - 1650 SERIES Bearing Diameter = 1.772"	PT HB88509A
		SPICER 1650 - 1710 SERIES Bearing Diameter = 1.969"	PT HB88510
		SPICER 1710HD - 1810HD & ROCKWELL 88WB SERIES Bearing Diameter = 2.362"	PT HB88512A

DOMESTIC CENTER BEARING APPLICATIONS

Model	Year	PTC #
-------	------	-------

INTERNATIONAL

ALL MODELS	55-80		
		SPICER 1280 & 1310 SERIES	
		Bearing Diameter = 1.187"	PT HB206FF
		SPICER 1280 - 1410 & CLEVELAND S55 SERIES	
		Bearing Diameter = 1.378"	PT HB88107B
		SPICER 1480 - BW6C SERIES	
		Bearing Diameter = 1.575"	PT HB88508E
		SPICER 1610 - BW7C SERIES	
		Bearing Diameter = 1.772"	PT HB88509A
		SPICER 1700 - BW8C SERIES	
		Bearing Diameter = 1.969"	PT HB88510
		SPICER 1710HD - 1810HD & ROCKWELL 88WB SERIES	
		Bearing Diameter = 2.362"	PT HB88512A

KENWORTH

HEAVY DUTY	60-90		
		SPICER 1210 - 1310 SERIES	
		Bearing Diameter = 1.378"	PT HB88107B
		SPICER 1410 SERIES	
		Bearing Diameter = 1.575"	PT HB88508E
		SPICER 1550 - 1650 SERIES	
		Bearing Diameter = 1.772"	PT HB88509A
		SPICER 1650 - 1710 SERIES	
		Bearing Diameter = 1.969"	PT HB88510
		SPICER 1710HD - 1810HD & ROCKWELL 88WB SERIES	
		Bearing Diameter = 2.362"	PT HB88512A

MACK

MEDIUM & HEAVY DUTY	60-95		
		SPICER 1410 SERIES	
		Bearing Diameter = 1.575"	PT HB88508E
		SPICER 1550 - 1650 SERIES	
		Bearing Diameter = 1.772"	PT HB88509A
		SPICER 1650 - 1710 SERIES	
		Bearing Diameter = 1.969"	PT HB88510
		SPICER 1710HD - 1810HD & ROCKWELL 88WB SERIES	
		Bearing Diameter = 2.362"	PT HB88512A

OLDSMOBILE

ALL MODELS	90-95		
		SPICER 1210 - 1410 SERIES	
		Bearing Diameter = 1.378"	PT HB88107B
		SPICER 1210 - 1410 SERIES	
		Bearing Diameter = 1.378"	PT HB88107E

DOMESTIC CENTER BEARING APPLICATIONS

Model	Year	PTC #
-------	------	-------

OFF-HIGHWAY

ALL MODELS	60-95		
		SPICER 1210 - 1310 SERIES	
		Bearing Diameter = 1.378"	PT HB88107B
		SPICER 1410 SERIES	
		Bearing Diameter = 1.575"	PT HB88508E
		SPICER 1550 - 1650 SERIES	
		Bearing Diameter = 1.772"	PT HB88509A
		SPICER 1650 - 1710 SERIES	
		Bearing Diameter = 1.969"	PT HB88510
		SPICER 1710HD - 1810HD & ROCKWELL 88WB SERIES	
		Bearing Diameter = 2.362"	PT HB88512A

PETERBILT

ALL MODELS	60-95		
		SPICER 1210 - 1310 SERIES	
		Bearing Diameter = 1.378"	PT HB88107B
		SPICER 1410 SERIES	
		Bearing Diameter = 1.575"	PT HB88508E
		SPICER 1550 - 1650 SERIES	
		Bearing Diameter = 1.772"	PT HB88509A
		SPICER 1650 - 1710 SERIES	
		Bearing Diameter = 1.969"	PT HB88510
		SPICER 1710HD - 1810HD & ROCKWELL 88WB SERIES	
		Bearing Diameter = 2.362"	PT HB88512A

WARD LA FRANCE

ALL MODELS	60-85		
		SPICER 1210 - 1310 SERIES	
		Bearing Diameter = 1.378"	PT HB88107B
		SPICER 1410 SERIES	
		Bearing Diameter = 1.575"	PT HB88508E
		SPICER 1550 - 1650 SERIES	
		Bearing Diameter = 1.772"	PT HB88509A
		SPICER 1650 - 1710 SERIES	
		Bearing Diameter = 1.969"	PT HB88510
		SPICER 1710HD - 1810HD & ROCKWELL 88WB SERIES	
		Bearing Diameter = 2.362"	PT HB88512A

WESTERN STAR

HEAVY DUTY	60-85		
		SPICER 1210 - 1310 SERIES	
		Bearing Diameter = 1.378"	PT HB88107B
		SPICER 1410 SERIES	
		Bearing Diameter = 1.575"	PT HB88508E
		SPICER 1550 - 1650 SERIES	
		Bearing Diameter = 1.772"	PT HB88509A
		SPICER 1650 - 1710 SERIES	
		Bearing Diameter = 1.969"	PT HB88510
		SPICER 1710HD - 1810HD & ROCKWELL 88WB SERIES	
		Bearing Diameter = 2.362"	PT HB88512A

DOMESTIC CENTER BEARING APPLICATIONS

Model	Year	PTC #
-------	------	-------

WHITE

HEAVY DUTY	60-95		
		SPICER 1210 - 1310 SERIES	
		Bearing Diameter = 1.378"	PT HB88107B
		SPICER 1410 SERIES	
		Bearing Diameter = 1.575"	PT HB88508E
		SPICER 1550 - 1650 SERIES	
		Bearing Diameter = 1.772"	PT HB88509A
		SPICER 1650 - 1710 SERIES	
		Bearing Diameter = 1.969"	PT HB88510
		SPICER 1710HD - 1810HD & ROCKWELL 88WB SERIES	
		Bearing Diameter = 2.362"	PT HB88512A

IMPORT CENTER BEARING APPLICATIONS

Make	Year	Model	PTC #
CHEVEROLET	1972-82	LUV (2WD)	PT HB20
	1979-82	LUV (4WD)	PT HB21
DODGE	1979-82	D50	PT HB14
	1983-86	Power Ram 50	PT HB14
	1983-89	Ram 50	PT HB14
	1985-91	Colt / Vista	PT HB25
INFINITI	1990-93	M30	PT HB6
ISUZU	1981-87	Pick-up (2WD)	PT HB20
	1981-87	Pick-up (4WD)	PT HB21
	1984-87	Trooper	PT HB21
	1990-UP	Rodeo UCB (2WD)	PT HB32
MAZDA	1982-92	All Models	PT HB29
MITSUBISHI	1983-86	Mighty Max	PT HB14
	1987-89	Mighty Max (2WD)	PT HB14
	1987-93	Pick-up (4WD)	PT HB30
NISSAN	1973-76	610	PT HB19
	1973-79	620 Pick-up	PT HB18
	1977-81	810	PT HB19
	1977-83	200SX	PT HB19
	1980-86	720 Pick-up	PT HB12
	1982-84	Maxima	PT HB6
	1984-88	200SX	PT HB6
	1986-88	Stanza Wagon AWD	PT HB6
	1986-89	Multi-Wagon AWD (Canadian Models)	PT HB6
	1986-95	Hardbody Pick-up (2WD) (L4)	PT HB6
	1986-95	Hardbody Pick-up (4WD) (V6) (Made in Japan)	PT HB13
	1987-95	Pathfinder (2WD) (L4)	PT HB6
	1987-95	Pathfinder (4WD) (V6) (Made in Japan)	PT HB13
	1989-94	240SX	PT HB6
	1995	240SX (A/T)	PT HB6
PLYMOUTH	1979-82	Arrow	PT HB14
TOYOTA	1971-83	Corolla	PT HB11
	1973-75	Pick-up	PT HB16
	1978-84	Cressida	PT HB8
	1979-83	Pick-up	PT HB9
	1982-85	Celica	PT HB7
	1982-85	Supra	PT HB7
	1983-88	Terrel Wagon AWD	PT HB7
	1984-88	Pick-up (4WD)	PT HB17
	1984-88	Pick-up (2WD)	PT HB10
	1989-95	Pick-up (2WD)	PT HB9
	1989-95	Pick-up (4WD)	PT HB24
	1989-95	Pick-up (2WD)	PT HB27
	1993-97	T100 (2WD)	PT HB26
	1993-97	T100 (4WD)	PT HB28
	1995-97	Tacoma	PT HB31

<p>PT DS15N</p> 	<p>PT DS18</p> 	<p>PT HB2</p> 
<p>PT HB3</p> 	<p>PT HB6</p> 	<p>PT HB7</p> 
<p>PT HB8</p> 	<p>PT HB9</p> 	<p>PT HB10</p> 
<p>PT HB11</p> 	<p>PT HB12</p> 	<p>PT HB13</p> 
<p>PT HB14</p> 	<p>PT HB16</p> 	<p>PT HB17</p> 

PT HB18



PT HB20



PT HB21



PT HB24



PT HB25



PT HB26



PT HB27



PT HB28



PT HB29



PT HB30



PT HB31



PT HB32



PT HB33



PT HB106FF



PT HB206FF



<p>PT HB88107-A</p> 	<p>PT HB88107-B</p> 	<p>PT HB88107-C</p> 
<p>PT HB88107-D</p> 	<p>PT HB88107-E</p> 	<p>PT HB88508</p> 
<p>PT HB88508-A</p> 	<p>PT HB88508-AA</p> 	<p>PT HB88508-AB</p> 
<p>PT HB88508-B</p> 	<p>PT HB88508-C</p> 	<p>PT HB88508-D</p> 
<p>PT HB88508-E</p> 	<p>PT HB88509</p> 	<p>PT HB88509-A</p> 

PT HB88509-B

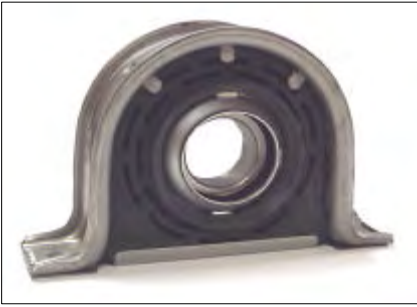

PT HB88509-C



PT HB88510

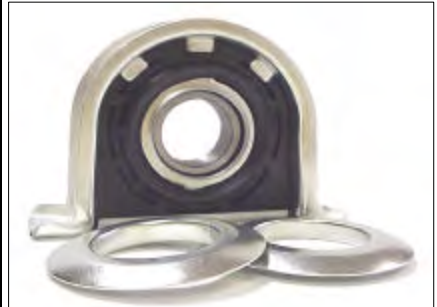

PT HB88510-S



PT HB88512-A



PT HB88512-AHD



PT HB88512-ASHD



IDENTIFICATION & QUICK REFERENCE LISTING

DRIVESHAFT CENTER SUPPORT ROLLER TYPE

PTC #	SPICER #	PREC #	INSIDE		CENTERLINE TO MNTG SURFACE	BOLT HOLE TO BOLT HOLE
			BRG DIAM.			
			mm	inches		
PT HB2	211303X	9860	-----	1.500"	3.875" brg diam	2.000" brg width
PT HB3	211304X	9875	-----	1.750"	4.250" brg diam	2.500" brg width

BALL TYPE

PT HB106FF	211431X		32	1.2600"	1.950"	5.900"
PT HB108						
PT HB206FF	210527X	9800	30	1.1811"	3.500"	-----
PT HBD206F	211590X		30	1.1811"	1.950"	5.900"
PT HB88107-A	211187X	9845	35	1.3780"	2.280"	6.625"
PT HB88107-B	210088-1X	9811	35	1.3780"	2.230"	6.600"
PT HB88107-C	210090-1X	9812	35	1.3780"	2.230"	6.600"
PT HB88107-D	210367-1X	9816	35	1.3780"	2.230"	6.600"
PT HB88107-E	210370-1X	9817	35	1.3780"	2.230"	6.600"
PT HB88508	211098-1X	9850	40	1.5750"	2.480"	6.625"
PT HB88508-A	211016X	9830	40	1.5750"	2.280"	6.620"
PT HB88508-AA	210873-1X	9832	40	1.5750"	2.280"	6.620"
PT HB88508-AB	210866-1X	9831	40	1.5750"	2.280"	6.620"
PT HB88508-B	210433-1X	9852	40	1.5750"	2.480"	6.625"
PT HB88508-C	210140-1X	9856	40	1.5750"	2.480"	6.625"
PT HB88508-D	210144-1X	9857	40	1.5750"	2.480"	6.625"
PT HB88508-E	210391-1X	9851	40	1.5750"	2.480"	6.625"
PT HB88509	210969X	9865	45	1.7720"	2.700"	7.600"
PT HB88509-A	210084-2X	9866	45	1.7720"	2.700"	7.600"
PT HB88509-B	210130-1X	9870	45	1.7720"	2.700"	7.600"
PT HB88509-C	210207-1X	9867	45	1.7720"	2.700"	7.600"
PT HB88510	210121-1X	9880	50	1.9680"	2.810"	7.620"
PT HB88510-S	210881-1X	9881	50	1.9680"	2.810"	7.620"
PT HB88512-A	210661-1X	9885	60	2.3620"	3.370"	8.630"
PT HB88512-ASHD	210875-1X	9886	60	2.3620"	3.370"	8.630"

DRIVESHAFT CENTER SUPPORT IMPORT HANGER BEARINGS

PTC #	SPICER #	PREC #	INSIDE		OUTSIDE DIAMETER	WIDTH
			BRG DIAM.			
			mm	inches		
PT HB6	212803	9963	30	1.1811"	4.3315"	2.089"
PT HB7	223802		30	1.1811"	4.2245"	2.3361"
PT HB8			30	1.1811"	4.2335"	2.2965"
PT HB9	213801	9951	30	1.1811"	4.8155"	2.2635"
PT HB10	213803	9953	30	1.1811"	4.7505"	2.3661"
PT HB11			30	1.1811"	4.1815"	2.3455"
PT HB12	212802	9962	30	1.1811"	4.7465"	1.9341"
PT HB13	212804	9964	30	1.1811"	4.7075"	2.0375"

**DRIVESHAFT CENTER SUPPORT
IMPORT HANGER BEARINGS**

PTC #	SPICER #	PREC #	INSIDE		OUTSIDE DIAMETER	WIDTH
			BRG DIAM.			
			mm	inches		
PT HB14	216801	9971	30	1.1811"	4.6115"	2.3338"
PT HB16			30	1.1811"	4.3315"	2.6365"
PT HB17	213802	9952	30	1.1811"	4.1845"	2.3355"
PT HB18	212801		30	1.1811"	4.6845"	2.4425"
PT HB20			25	0.9843"	2.1245"	1.5675"
PT HB21	217001		25	0.9843"	2.1321"	1.5375"
PT HB24	213804	9954	30	1.1811"	4.6955"	2.1245"
PT HB25			30	1.1811"	4.6305"	2.3855"
PT HB26	213805	9956	30	1.1811"	4.2705"	2.29"
PT HB27			30	1.1811"	4.1875"	2.285"
PT HB28	213807		30	1.1811"	4.29"	2.3125"
PT HB29			25	0.9843"	4.525"	2.625"
PT HB30	227030		30	1.1811"	4.67"	2.35"
PT HB31	223804		30	1.1811"	4.3415"	2.3125"
PT HB32	215501		30	1.1811"	4.64"	2.364"
PT HB33	227033		30	1.1811"	4.64"	2.364"

AEC	PTC
40012	10-4-123
40022	10-4-22
40033	10-4-33
40053	10-4-53
40063	10-4-63
40076	10-4-643
40081	10-4-11
40083	10-4-83
40095	10-4-163
40113	10-4-113
40115	10-4-183
40124	10-4-153
41103	10-3-51
41112	10-3-12
41113	10-3-13
41122	10-3-22
41123	10-3-23
41132	10-3-32
41133	10-3-33
41153	10-3-83
41181	10-3-81
41193	10-3-183
42013	10-4-693
42043	10-4-173
42093	10-4-723

ALLOY	PTC
1001	PT521HD
1002	PT521HD
1004	PT521HD
1005	PT521HD
1006	PT350
1007	PT456
1008	PT1622
1010	PT1200
1011	PT675
1012	PT1203
1013	PT1204
1014	PT3105
1015	PT3105
1016	PT1625
1017	PT1619
1018	PT1620
1019	PT266
1020	PT231
1021	PT504
1022	PT1623
1023	PT501
1024	PT260
1025	PT260
1027	PT514
1028	PT521H DU
1029	PT1610
1030	PT501
1031	PT514
1032	PT521HD
1034	PT534
1038	PT521H DU
1039	PT521H DU
1040	PT530
1041	PT248
1042	PT3188

ALLOY	PTC
1043	PT1621
1046	PT356
1048	PT260
1049	PT1604
1050	PT1604
1051	PT1602
1052	PT1603
1053	PT1605
1056	PT1750G
1057	PT1601
1058	PT1616
1059	PT1606
1060	PT1617
1061	PT1750G
1063	PT2116
1064	PT2126
1066	PT2140
1067	PT2173
1068	PT2173
1070	PT570
1071	PT2127
1077	PT2500
1078	PT578
1079	PT2530
1085	PT3188
1103	PT233
1105	PT267
1131	PT1200
1153	PT353
1175	PTCVK1
1177	PTCVK5
1178	PTCVK2A
1180	PTCVK5
1181	PTCVK1
1699	PT356
1706	PT4113
1720	PT5100
1722	PT5102
1723	PT5110
1724	PT5102
1728	PT5108
1731	PT5111
1732	PT5111
1739	PT373
1740	PT373
1741	PT456
1742	PT456
1746	PT358
1750	PT560
1751	PT578U
1752	PT560U
1756	PT588
1757	PT515
1758	PT297
1761	PT497
1763	PT1206
1764	PT1206
1774	PT44N
1777	PT6N8
1778	PT6N8
1779	PT12N
1780	PT14N
1781	PT35N

ALLOY	PTC
1784	PT2127
1785	PT55N
1786	PT570
1801	PT565
1802	PT280
1803	PT280
1804	PT524
1805	PT555
1806	PT279
1807	PT279
1808	PT407
1810	PT281
1820	PT6100
1821	PT6101
1822	PT6102
1826	PT6106
1840	PT7105
1841	PT7100
1843	PT7102
1850	PT8105
1851	PT8200
1852	PT8201
1853	PT8202
1854	PT8203
1864	PT9014
1865	PT9017
1866	PT9031
1867	PT9017
1868	PT9031
1876	PT58WB1
1877	PT58WB2
1878	PT58WB
40179	PTSCV79
40180	PTSCV42
40782	PTSCV82
41002	PT521HDSJ
41004	PT521HDSJ
41006	PT350
41008	PT1622
41010	1200SJ
41011	PT675
41012	PT1203SJ
41013	1204SJ
41014	3105SJ
41016	PT1625
41017	1619SJ
41018	PT1620
41019	PT266
41020	PT231
41023	PT501
41025	260SJ
41027	PT514
41029	PT1610
41034	PT534
41043	PT1621
41048	260SJ
41050	PT1604
41051	PT1602
41052	PT1603
41053	PT1605
41057	PT1601
41058	PT1616
41060	PT1617

ALLOY	PTC
41065	PT360
41077	PT2500
41078	578SJ
41103	PT266
41153	PT353
41154	PT495
41155	PT332
41741	456SJ
41742	456SJ
41746	PT358
41750	PT560
41758	297SJ
41761	PT497SJ
41777	PT6N8
41779	PT12N
41780	PT14N
41781	PT35N
51004	PT521HD
51042	PT3188CC
51078	PT578
51699	PT356
0502	10-4-173
0502	10-4-43
0503	10-4-253
0503	10-4-453
0505	10-4-643
0506	10-4-373
0507	10-4-693
0508	10-4-713
0509	10-4-703
0510	10-4-683
0511	10-4-723
0512	10-4-693
0515	10-3-163
0517	10-4-73
0518	10-4-573
0519	10-4-113
0520	10-4-153
0521	10-4-193
0525	10-4-133
0525	10-4-13
0526	10-4-13
0526	10-4-11
0531	10-4-443
0532	10-3-23
0533	10-4-101
0534	10-3-81
0537	10-3-163
0539	10-3-32
0543	10-3-13
0544	10-3-162
0546	10-3-83
0547	10-4-31
0550	10-4-163
0552	10-4-103
0552	10-4-143
0553	10-3-183
4996S	PT102
4999S	PT103
5821S	PT106
6013S	PT105
6025S	PT107
6026S	PT113

BECK-ARNLEY (World Parts)	PTC
102-0023	PT521HD
102-0031	PT504
102-0056	PT514
102-0098	PT514
102-0106	PT504
102-0114	PT521HD
102-0130	PT560
102-0148	PT1601
102-0155	PT514
102-0262	PT1606
102-0288	PT1604
102-0296	PT1605
102-0304	PT1616
102-0312	PT1617
102-0320	PT1610
102-0338	PT1622
102-0353	PT1604
102-0361	PT1603
102-0379	PT1602
102-0387	PT501
102-0395	PT1620
102-0403	PT1602
102-0429	PT1625
102-0437	PT1623S
102-0445	PT514
102-0452	PT1616
102-0460	PT1619
102-0478	PT1619
102-0479	PT1621
102-0481	PT1625
102-0482	PT1601
102-0483	PT2500
102-0486	PT1622
102-0488	PT1606

BORG WARNER	PTC
100-12	10-4-12
100-13	10-4-13
100-22	10-4-22
100-23	10-4-23
100-24	10-4-153
100-33	10-4-33
100-43	10-4-43
100-53	10-4-53
100-63	10-4-63
100-73	10-4-73
100-81	10-4-11
100-83	10-4-83
100-93	10-4-93
100-95	10-4-163
100-103	10-4-103
100-113	10-4-113
100-115	10-4-183
100-123	10-4-123
101-12	10-3-12
101-13	10-3-13
101-22	10-3-22
101-23	10-3-23

BORG WARNER	PTC
101-32	10-3-32
101-33	10-3-33
101-53	10-3-83
101-81	10-3-81
101-103	10-3-51
102-13	10-4-133
102-43	10-4-173
102-93	10-4-723
11-76	10-4-643
54342	10-4-183
54347	10-3-51
65111	10-4-13
65112	10-4-43
65113	10-4-63
65114	10-4-73
65115	10-4-93
65116	10-4-113
65117	10-4-153
65125	10-4-123
65134	10-4-11
65136	10-4-43
65139	10-4-83
65157	10-3-23
65159	10-3-81
65171	10-4-22
65173	10-3-32
65176	10-3-12
65178	10-3-22
6518	10-4-123
65183	10-3-13
65184	10-3-33
65186	10-3-83
65189	10-4-12
65191	10-4-163
65193	10-4-52
65196	10-4-103
65199	10-3-183
65217	10-3-122
65268	10-4-23
65338	10-4-643
65371	10-4-133
65372	10-4-173
65375	10-4-723
114-1HD	PT231
114-2HD	PT266
114-3HD	PT521HD
114-4HD	PT3105
114-5HD	PT1203
114-6HD	PT1204
114-7HD	PT1200
114-8HD	PT675
114-9HD	PT356
114-10HD	PT578
114-1HP	PT231
114-2-HP	PT266
114-3HD	PT521HD
114-4HD	PT3105
114-5HD	PT1203
114-6HD	PT1204
114-7HD	PT1200
114-8HD	PT675

BORG WARNER	PTC
114-9HD	PT356
114-10HD	PT578
114-103	PT12N
114-104	PT14N
114-105	PT35N
114-107	PT58WB
114-108	PT58WB1
114-109	PT58WB2
114-121	PT1206
114-122	PT1203
114-123	PT1204
114-125	PT1200
114-126	PT675
114-150	PT55N
114-151	PT44N
114-212	PT3188
114-213	PT1203
114-215	PT280HR
114-231	PT231
114-232	PT231
114-233	PT233
114-255	PT266
114-266	PT266
114-266M	PT233/PT266
114-301	PT514
114-302	PT1603
114-303	PT1604
114-304	PT1602
114-305	PT1616
114-306	PT1605
114-307	PT1604
114-308	PT1617
114-309	PT1606
114-310	PT1601
114-311	PT1610
114-315	PT456
114-316	PT353
114-317	PT1625
114-320	PT1620
114-321	PT1619
114-350	PT350
114-362	PT373
114-372	PT373
114-373	PT373
114-407	PT407
114-418UB	PT103
114-428UB	PT102
114-438	PT279HR
114-438UB	PT105
114-448SK	PT106
114-456	PT456
114-460	PT358
114-458SK	PT108
114-468SK	PT107
114-500	PT521HD
114-501	PT501
114-504	PT504
114-513	PT521HD
114-513R	PT521HD
114-513X	PT521HD
114-514	PT514

BORG WARNER	PTC
114-515	PT515
114-515R	PT515
114-515X	PT515
114-516	PT279
114-516R	PT279
114-516X	PT279
114-517	PT280
114-517R	PT280
114-517X	PT280
114-520	PT521HD
114-520U	PT521HDU
114-521	PT521HD
114-521HD	PT521HD
114-521R	PT521HD
114-521U	PT521HDU
114-521RU	PT521HDU
114-521X	PT521HD
114-524	PT524
114-527	PT360
114-530	PT1203
114-536	PT3188
114-548	PT248
114-549	PT521HD
114-552	PT534
114-553	PT521HD
114-555	PT555
114-560	PT560
114-560R	PT560
114-560U	PT560U
114-565	PT565
114-570	PT570
114-572	PT501
114-573	PT260
114-573B	PT496
114-577	PT280
114-578	PT578
114-578B	PT498
114-578R	PT578
114-578U	PT578U
114-581	PT514
114-588	PT588
114-588R	PT588
114-636	PT332
114-640	PT281
114-645	PT297
114-645B	PT497
114-1002	PT6N8
114-1003	PT6N8
114-1004	PT6N8
114-1005	PT6N8
114-1007	PT6N8
114-1009	PT6N8
114-1750	PT1750G
114-1762	PT1750G
114-1763	PT1750G
114-1765	PT1750G
114-1767	PT1750G
114-1771	PT1750G
114-1773	PT1750G
114-2005	PT2126
114-2007	PT2127

BORG WARNER	PTC
114-2010	PT2126
114-2011	PT2127
114-2016	PT2127
114-2031	PT2126
114-2036	PT2126
114-2039	PT2127
114-2040	PT2126
114-2045	PT2126
114-2046	PT2127
114-2048	PT2126
114-2050	PT2127
114-2063	PT2127
114-2064	PT2127
114-2076	PT2126
114-2077	PT2126
114-2100	PT2126
114-2101	PT2127
114-2104	PT2116
114-2108	PT2127
114-2111	PT2126
114-2112	PT2127
114-2115	PT2116
114-2116	PT2116
114-2118	PT2126
114-2119	PT2127
114-2121	PT2127
114-2122	PT2126
114-2124	PT2127
114-2126	PT2126
114-2127	PT2127
114-2130	PT2116
114-2131	PT2127
114-2132	PT2127
114-2133	PT2127
114-2134	PT2126
114-2137	PT2127
114-2140	PT2140
114-2143	PT2116
114-2144	PT2127
114-2145	PT2127
114-2148	PT2126
114-2151	PT2127
114-2153	PT2140
114-2155	PT2126
114-2156	PT2116
114-2157	PT2126
114-2158	PT2126
114-2160	PT2127
114-2161	PT2127
114-2163	PT2126
114-2164	PT2127
114-2165	PT2173
114-2168	PT2127
114-2170	PT2116
114-2172	PT2116
114-2173	PT2173
114-2174	PT2127
114-2175	PT2173
114-2177	PT2127
114-2178	PT2173
114-2179	PT2127

BORG WARNER	PTC
114-2180	PT2173
114-2181	PT2173
114-2182	PT2127
114-2184	PT2127
114-2185	PT2116
114-2187	PT2127
114-2188	PT2126
114-2206	PT2116
114-2500	PT2500
114-2501	PT2500
114-2505	PT2500
114-2518	PT2530
114-2530	PT2530
114-2531	PT2530
114-2532	PT2500
114-3008	PT3105
114-3011	PT3105
114-3033	PT3105
114-3105	PT3105
114-3111	PT3105
114-3114	PT3105
114-3127	PT3105
114-3133	PT3105
114-3147	PT3105
114-4110	PT4140
114-4111	PT4140
114-4113	PT4113
114-4118	PT4113
114-4120	PT4113
114-4121	PT4113
114-4130	PT4140
114-4140	PT4140
114-4143	PT4113
114-4146	PT4140
114-4149	PT4113
114-4158	PT4113
114-4162	PT4140
114-4179	PT4140
114-5000	PT5100
114-5003	PT5100
114-5008	PT5110
114-2011	PT5100
114-5014	PT5100
114-5024	PT5100
114-5036	PT5110
114-5055	PT5100
114-5100	PT5100
114-5103	PT5110
114-5108	PT5108
114-5111	PT5111
114-5117	PT5108
114-5118	PT5100
114-5120	PT5100
114-5122	PT5100
114-5123	PT5100
114-5124	PT5100
114-5125	PT5102
115-5128	PT5100
114-5129	PT5108
114-5130	PT5102
114-5131	PT5111

BORG WARNER	PTC
114-5132	PT5110
114-5134	PT5110
114-5135	PT5110
114-5137	PT5100
114-5140	PT5111
114-5143	PT5111
114-5145	PT5100
114-5146	PT5108
114-5149	PT5102
114-5152	PT5111
114-5154	PT5111
114-5161	PT5111
114-5163	PT5108
114-5173	PT5102
114-5174	PT5108
114-5175	PT5111
114-5176	PT5102
114-5177	PT5108
114-5178	PT5100
114-5180	PT5108
114-6000	PT6100
114-6003	PT6100
114-6004	PT6101
114-6016	PT6100
114-6022	PT6102
114-6029	PT6101
114-6100	PT6100
114-6101	PT6101
114-6102	PT6102
114-6106	PT6106
114-6110	PT6106
114-6113	PT6100
114-6114	PT6102
114-6115	PT6102
114-6117	PT6100
114-6118	PT6106
114-6119	PT6106
114-6120	PT6100
114-6121	PT6101
114-6122	PT6102
114-6125	PT6102
114-6127	PT6106
114-6128	PT6106
114-6129	PT6100
114-6130	PT6106
114-6132	PT6106
114-6133	PT6100
114-6137	PT6100
114-6141	PT6100
114-6142	PT6102
114-6143	PT6100
114-6144	PT6102
114-6145	PT6101
114-6146	PT6106
114-6151	PT6106
114-6152	PT6101
114-6155	PT6106
114-6161	PT6101
114-6172	PT6100
114-6173	PT6106
114-6181	PT6106

BORG WARNER	PTC
114-7000	PT7100
114-7003	PT7100
114-7033	PT7100
114-7034	PT7102
114-7035	PT7100
114-7100	PT7100
114-7102	PT7102
114-7105	PT7105
114-7107	PT7105
114-7110	PT7105
114-7111	PT7105
114-7112	PT7105
114-7113	PT7105
114-7114	PT7102
114-7116	PT7100
114-7117	PT7105
114-7118	PT7100
114-7119	PT7105
114-7120	PT7100
114-7121	PT7105
114-7122	PT7105
114-7123	PT7105
114-7124	PT7105
114-7125	PT7105
114-7126	PT7105
114-7127	PT7105
114-7129	PT7105
114-7130	PT7105
114-7131	PT7105
114-7200	PT7100
114-7202	PT7102
114-7205	PT7100
114-7207	PT7102
114-7211	PT7100
114-7212	PT7100
114-7213	PT7100
114-7216	PT7100
114-7217	PT7102
114-7218	PT7100
114-7220	PT7102
114-7221	PT7100
114-7222	PT7100
114-7223	PT7102
114-7225	PT7100
114-7226	PT7102
114-7227	PT7102
114-7228	PT7100
114-7230	PT7100
114-7231	PT7102
114-7234	PT7100
114-7242	PT7100
114-7245	PT7102
114-7246	PT7102
114-7248	PT7100
114-7249	PT7102
114-7270	PT7102
114-8000	PT8200
114-8002	PT8200
114-8003	PT8201
114-8018	PT8200
114-8023	PT8201

BORG WARNER	PTC
114-8025	PT8200
114-8100	PT8200
114-8101	PT8201
114-8102	PT8202
114-8103	PT8203
114-8105	PT8105
114-8107	PT8105
114-8111	PT8105
114-8112	PT8105
114-8113	PT8105
114-8115	PT8105
114-8116	PT8105
114-8117	PT8105
114-8118	PT8105
114-8119	PT8105
114-8120	PT8105
114-8121	PT8105
114-8200	PT8200
114-8201	PT8201
114-8202	PT8202
114-8203	PT8203
114-8205	PT8200
114-8206	PT8201
114-8207	PT8202
114-8208	PT8203
114-8210	PT8200
114-8211	PT8201
114-8212	PT8200
114-8213	PT8202
114-8215	PT8202
114-8216	PT8202
114-8217	PT8200
114-8218	PT8200
114-8219	PT8202
114-8221	PT8201
114-8222	PT8200
114-8223	PT8200
114-8224	PT8200
114-8226	PT8200
114-9016A	PT9031
114-9035	PT9014
114-9036	PT9014
114-9037	PT9014
114-9038	PT9031
114-9039	PT9031
114-9040	PT9031
114-9041	PT9031
114-9043	PT9031
114-9044	PT9031
114-9045	PT9031
114-9046	PT9014
114-9047	PT9017
114-9048	PT9014
114-9050	PT9031
114-9058	PT9014
117-110	PTCVK-1
117-111	PTCVK-1
117-112	PTCVK-2A
117-115A	PTCVK-5
117-116	PTCVK-5
117-118	PTSCV76

BORG WARNER	PTC
117-119	PTSCV82A
117-1342J	PTSCV42
117-1779J	PTSCV79
117-1782J	PTSCV82
CP5N	PT515
CPL6N	PT6N8
CPL12N	PT12N
CPL14N	PT14N
CP35N-3	PT35N
CP35N-4	PT35N
CP58WB	PTCP58WB
CP58WB-1	PT58WB1
CP58WB-2	PT58WB2
055-55-2	PT1206
P55-55-2	PT1203
P55-55-675	PT1204
S55-55-1	PT1200
S55-55-2	PT1200
S55-55-675	PT675
X55-55	PT570

CATERPILLAR	PTC
159670	PT6106
542213	PT560
641152	PT7100
643633	PT6102
673626	PT2126
686343	PT8105
686690	PT6102
773127	PT560
775152	PT279
775226	PT578
815009	PT22GB
817189	PT570
817190	PT570
826860	PT504
8331834	PT560
942737	PT5100
943235	PT5100
945581	PT2116
982915	PT501
9C0397	PT58WB1
9C0398	PT58WB2
9C0779	PT555
9C4537	PT521HD
9C8367	PT555
2D1844	PT4113
2D3765	PT2126
4D8212	PT2126
7D2059	PT570
8D0537	PT5108
8D2909	PT6N8
8D3144	PT9031
8D7719	PT7105
7F3679	PT35N
6G4356	PT5108
7G9555	PT6108
2H0858	PT7105
3H0301	PT6106
3H6104	PT7105

CATERPILLAR	PTC
3H6263	PT6N8
3H6449	PT9031
3H7364	PT6106
4H7808	PT2126
5H2308	PT8105
5H3756	PT9031
6H2577	PT7105
6H2579	PT8105
7H3958	PT9031
9H2477	PT6106
9H2478	PT6106
9H9491	PT6014
1J0843	PT5108
7J5242	PT7102
7J5251	PT5100
2K3631	PT5108
3K7276	PT7105
5K5012	PT4113
6K0316	PT4113
6K0885	PT9031
7K2220	PT6N8
7K3526	PT6106
8K6042	PT7105
8K7002	PT6106
3L7363	PT35N
4L6325	PT7102
4L6929	PT8105
1M8804	PT8105
5M0800	PT4140
6M9762	PT9031
9P0356	PT7105
9P0604	PT9031
9P4809	PT8105
2R0801	PT9031
5R0056	PT2126
8R7752	PT560
1S0678	PT6N8
1S0687	PT6N8
1S9670	PT6106
5S5680	PT9031
5S7579	PT6N8
6S6902	PT2116
6S9266	PT5108
7S0990	PT4140
2T0095	PT6106
5T1362	PT5108
5T8739	PT5108
4V4735	PT9031
5V1168	PT4113
5V5474	PT555
5V7199	PT578
7V3842	PT280HR
7V4077	PT279HR
8V6431	PT555
8V6435	PT555
8V7177	PT279HR
8V7336	PT588
9V3812	PT9031
9V7705	PT9031
9V7710	PT9031
6W2916	PT280HR
8W9912	PT9031

CATERPILLAR	PTC
7X4960	PT578
7X4961	PT560
7X8698	PT570
2Y6471	PT6106
2Y7347	PT4113
8Y0809	PT5108
D2X2202	PT2126
D2X2203	PT2116
D0740028	PT22GB
R2X1972	PT3105
R7X7355	PT3105
XX1894-7	PT5100
XX7146	PT8200

CHRYSLER (Detroit)	PTC
575784	PT373
747556	PT560
966932	PT560
1150809	PT521HD
1463491	PT2126
3218363	PT22GB
3276694	PT279
3306813	PT501
5037918	PT501
5038495	PT501
5038930	PT514
5039570	PT504
5040692	PT560
5040693	PT22GB
5041525	PT279
5044943	PT504
5057939	PT521HD
7080421	PT501
7080428	PT501
75060444	PT514
D18049	PT560
D18363	PT22GB
D4220/1	PT560
D18888/5	PT504
D19834/7	PT279
K18244	PT501
K18246	PT504
K22173	PT22GB
K22318	PT578
K23645	PT560
K23703	PT514
K23704	PT514
K23958	PT514
K26110	PT279
K26345	PT560
M21005	PT279
11614L	PT514
34224	PT514
34244Y	PT501
34254S	PT501
947547	PT504
947553	PT373
1064846	PT373
1321115	PT521HD
1516853	PT560

CHRYSLER (Detroit)	PTC
1516854	PT578
1643242	PT521HD
1752307	PT588
1752317	PT279
1752325	PT515
1752412	PT560
1752624	PT266
1818920	PT521HD
1818921	PT521HD
1828824	PT106
1843030	PT570
1843143	PT260
1843347	PT1200
1881657	PT373
1925252	PT1200
2084313	PT555
2196041	PT280
2240231	PT570
2298823	PT578
2298908	PT266
2495043	PT565
2505767	PT55N
2533202	PT1203
2852175	PT231
3004900	PT233
3480934	PT353
3634563	PT231
3736380	PT12N
3744918	PT297
3780250	PT266
3780272	PT373
3780280	PT353
3820254	PT280
3820255	PT279
3822292	PT281
3827046	PT521HD
3837585	PT332
4030848	PT3105
4049697	PTCVK-2A
4057025	PT231
4137757	PT297
4137780	PT332
4213200	PT373
4364400	PT266
4364562	PT521HD
4384514	PT233
4384661	PT353
4384662	PT521HD
4384663	PTSCV82
4428723	PT110UJ
4428800	PT560
4443100	PT233
4504575	PT231
4720822	PT233
4728937	PT521HD
4741304	PT362
4746936	PT1203
4773162	PT362
4797307	PT578
4882793	PT521HD
4897484	PTSCV82

CHRYSLER (Detroit)	PTC
5003004AA	PT332
5003146AA	PT560
52097559	PT231
52125237	PT231
53000029	PT521HD
J3203992	PT2127
J3208473	PT521HD
J3233715	PT353
J3240553	PT107UJ
J8126613	PT521HD
J8126614	PT521HD
J8126636	PT266
J8126637	PT260
J8126638	PT297
J8130303	PTSCV82
J8130750	PT495
MA126433	PT1601
MB000345	PT1601
MB000390	PT1601
MB000391	PT1601
MB000393	PT1601
MB000776	PT1625
MB000823	PT1625
MB000826	PT1625
MB000827	PT1601
MB000948	PT1625
MB154261	PT1625
MB154485	PT1625
MB154554	PT1601
MR196899	PT1601
MST00024	PT1601
MST05012	PT1601

EUCLID/ TEREX	PTC
20268	PT2127
21296	PT279
21682	PT7100
21683	PT7100
21686	PT8200
22623	PT7100
44138	PT9031
47079	PT7100
47097	PT7100
47903	PT524
47985	PT280
84559	PT524
695232	PT280
2173956	PT279
2173960	PT280
2222853	PT280
2222854	PT279
22223567	PT515
2224005	PT524
2298621	PT560
2322134	PT515
2322136	PT279
2322137	PT280
2322138	PT280
2335006	PT524

EUCLID/ TEREX	PTC
2336727	PT524
2354320	PT521HD
2362830	PT521HD
2366108	PT280
2400938	PT555
2403229	PT565
4016484	PT280
4016929	PT565
4025348	PT281
4026301	PT524
7500055	PT280
7501016	PT578
9020268	PT2126
9020304	PT6N8
9021251	PT8200
9021683	PT7100
9021686	PT8200
9021875	PT9014
9022503	PT8200
9022625	PT8200
9022626	PT7102
9022733	PT8202
9022734	PT7100
9022735	PT9031
9022756	PT8201
9022763	PT8200
9022766	PT9014
9023360	PT6N8
9023656	PT515
9023672	PT8105
9023673	PT521HD
9023940	PT7105
9024660	PT7100
9024673	PT8200
9024678	PT8202
9024705	PT7105
9024786	PT7102
9024790	PT7100
9024791	PT8202
9024794	PT8200
9024795	PT8202
9024891	PT6106
9024892	PT6N8
9024893	PT6N8
9024959	PT9014
9025207	PT8200
9025322	PT9014
9025543	PT9031
9025561	PT2126
9025578	PT5100
9025579	PT7102
9025580	PT8105
9025634	PT9014
9025635	PT9031
9025903	PT6106
9026434	PT9017
9026501	PT7102
9026503	PT7100
9026504	PT8202
9026505	PT8200
9026536	PT8201

EUCLID/ TEREX	PTC
9026892	PT8105
9026919	PT4140
9027735	PT9031
9027758	PT9031
9027855	PT7105
9027856	PT8105
9029107	PT9017
9030220	PT7105
9030836	PT524
9031316	PT524
9032043	PT7105
9033903	PT6100
9033904	PT6102
9034661	PT9031
9036203	PT555
9036325	PT7105
9037580	PT6102
9038235	PT7100
9038445	PT6100
9038448	PT6N8
9038734	PT5102
9039278	PT280
9042934	PT2500
9044138	PT9031
9044943	PT2500
9046306	PT8200
9046315	PT7100
9049686	PT524
9049775	PT9014
9051383	PT6102
9051384	PT6106
9052137	PT7105
9052140	PT7102
9052141	PT7100
9052499	PT6N8
9052692	PT281
9053683	PT9017
9053744	PT555
9053745	PT565
9053746	PT280
9053747	PT9017
9053828	PT6N8
9054662	PT280
9244286	PT9031
9385348	PT524
9385452	PT279
9388999	PT279
9389358	PT524
9390589	PT501
9392534	PT524
9395159	PT565
9397204	PT6102
15265162	PT7105
15266671	PT280

FORD	PTC
EOA-7039	PT504
O1T-7039	PT578
O1Y-7039	PT521HD
100E-7039	PT514

FORD	PTC
105E-7039	PT504
105E-7039A	PT514
116E-4635A	PT501
116E-4635B	PT501
204E-7039	PT501
204E-7042	PT501
213E-4635A	PT504
400A-4635A	PT514
404E-4635A	PT504
508E-7039	PT22GB
528E-7039	PT560
568E-7039	PT22GB
2002E-4635A	PT279
2002E-4635B	PT280
2400E-4635A	PT504
2402E-4635A	PT521HD
3008E-4635A	PT501
3010E-4635A	PT504
3012E-4635A	PT501
243250	PT14N
1555456	PT501
1792216	PT501
A-281868	PT515
A0T-7039-A	PT578
A8Q-7039-A	PT515
A9LY-4635	PT521HD
A9LY-4635-A	PT521HD
B-4635-A	PT560
B2Q-7039-A	PT515
B2TZ-4635-A	PT515
B3TZ-4635-A	PT6100
B3TZ-4635-B	PT6100
B4TZ-4635-C	PT6102
B4TZ-4635-D	PT7100
B4TZ-4635-E	PT7102
B4TZ-4635-F	PT534
B4TZ-4635-H	PT6102
B4TZ-4635-K	PT7102
B5A-7039	PT2126
B5A-7039-A	PT2126
B5A-7042-A	PT2127
B5AZ-4635-A	PT2126
B5AZ-4635-B	PT2127
B5AZ-7039-A	PT2126
B5T-7039-A	PT578
B5TZ-4635-A	PT578
B6D-7039-A	PT521HD
B6S-7039-A	PT521HD
B6T-7039-A	PT560
B6TZ-4635	PT560
B6TZ-4635-A	PT521HD
B6TZ-4635-B	PT560
B6TZ-4635-C	PT2140
B7A-039-A	PT521HD
B7AZ-4635-A	PT521HD
B7S-7039-A	PT521HD
B8QH-4635-A	PT8200
B8QH-4635-B	PT8202
B8QH-4635-C	PT8200
B8QH-465-D	PT8202
B9A-7039-A	PT2140
B9AZ-4635-A	PT2140

FORD	PTC
B9TT-4724-A	PT534
B9TZ-3249-A	PT260
CAR 107625	PT504
CAR 116859	PT521HD
CBPN-3550-A	PT6N8
CBPN-3550-B	PT6N8
CTBA-18310	PT501
CODZ-4635-A	PT1750G
CODZ-7039-A	PT1750G
C1AA-4724-A	PT1200
C1AA-4724-B	PT675
C1AZ-4635-A	PT675
C1AZ-4635-C	PT1200
C1AZ-4635-D	PT675
C1TT-4529-B	PT109
C1TT-4724-A	PT588
C1TZ-3249-A	PT578
C1TZ-4635-A	PT588
C1TZ-4635-B	PT534
C1UZ-4635-A	PT1750
C1VV-4497-A	PT521HD
C1VV-4997-A	PT521HD
C3AA-4635-A	PT1200
C3AA-4635-B	PT675
C3AZ-4635-A	PT1200
C3AZ-4635-B	PT675
C3AZ-4635-C	PT521HD
C3AZ-4635-D	PT675
C3AZ-4635-E	PT1200
C3AZ-4635-F	PT675
C3AZ-4635-G	PT1203
C3AZ-4635-H	PT1204
C3AZ-4635-J	PT1200
C3AZ-4635-K	PT675
C3AZ-4635-L	PT1203
C3AZ-4635-M	PT1204
C3DZ-4635-A	PT1750
C3SZ-4635-A	PT1200
C3TZ-3815-A	PT6N8
C3UZ-4635-A	PT1750
C3UZ-4635-B	PT1750
C3VY-4497-A	PT530
C3VY-4997-A	PT530
C4AZ-4635-A	PT8200
C4SZ-4635-A	PT530
C4SZ-4635-B	PT530
C4TA-4635-A	PT521HD
C4TA-4635-B	PT7100
C4TA-4635-E	PT6102
C4TA-4635-H	PT7102
C4TA-4635-J	PT8202
C4TA-4724-A	PT521HD
C4TZ-4635-A	PT521HD
C4TZ-4724-A	PT521HD
C4VW-4635-A	PT3188
C5DZ-4635-A	PT2173
C5DZ-4635-B	PT2127
C5TZ-3815-A	PT6N8
C5TZ-4635-B	PT1206
C5TZ-4635-C	PT521HD
C5TZ-4635-D	PT521HD
C5TZ-4635-E	PT578

FORD	PTC
C5TZ-4635-F	PT534
C5TZ-4635-G	PT1206
C5UZ-4635-A	PT1750
C5UZ-4635-B	PT1750
C6TZ-3249-A	PT260
C6TZ-3815-A	PT6N8
C6TZ-3815-B	PT6N8
C6TZ-4635	PT279
C6TZ-635-A	PT2530
C6TZ-4635-C	PT521HD
C6TZ-4635-E	PT565
C6TZ-4635-F	PT280
C6TZ-4635-G	PT279
C6TZ-4635-H	PT2500
C6TZ-4635-J	PT565
C6TZ-4635-K	PT280
C6TZ-4635-L	PT279
C7TZ-4635-A	PT524
C8SZ-4A031	PTCVK-1
C8SZ-4635-A	PT3105
C8UZ-4529-A	PT102
C9TZ-4635-A	PT530
C9TZ-4635-B	PT521HD
D1HZ-4635-A	PT524
D1TZ-3249-A	PT58WB1
D2HA-4635-AA	PT8200
D2HA-4635-BA	PT7102
D2HA-4635-CA	PT7100
D2HA-4635-DA	PT8202
D2HZ-4635-A	PT281
D2HZ-4635-B	PT524
D2TZ-4782-A	PTSCV82
D2TZ-4635-A	PT1610
D3AZ-4529-A	PT105
D3AZ-4529-B	PT105
D3AZ-4529-C	PT105
D3HZ-4635-A	PT7100
D3HZ-4635-B	PT7102
D3HZ-4635-C	PT8200
D3HZ-4635-D	PT8202
D3TZ-3249-A	PT297
D3TZ-4635-A	PT279
D3TZ-4635-B	PT280
D4HZ-4635-B	PT6100
D4NN-4N167-A	PT560
D8TZ-3249-A	PT332
D8UZ-4529-A	PT102
D8UZ-4529-B	PT103
D8UZ-529C	PT102
D8UZ-4529-E	PT103
D9HZ-4635-A	PT555
D9HZ-4635-B	PT407
D9OZ-4635-A	PT3105
DPTZ-4782-A	PTSCV79
E0TZ-3249-A	PT578
E3TZ-3249-A	PT456
E3TZ-4Z254-A	PT107A
E3TZ-4635-A	PT456
E3TZ-4635-B	PT315
E3TZ-4782-A	PTSCV42
E4HZ-4A254-B	PT110
E7HZ-4635-A	PT280HR

FORD	PTC
E7HZ-4635-B	PT279HR
E7TZ-4635-A	PT1204
E7TZ-4635-B	PT3105
E7TZ-4635-C	PT3188
E8HZ-4635-A	PT281HR
E8HZ-4635-B	PT407HR
E8TZ-4635-A	PT560
E9SZ-4635-W	PT521HD
E9SZ-4635-Z	PT530
E9TZ-4635-A	PT1204
E9TZ-4635-B	PT675
F1TZ-4635-A	PT521HD
F1TZ-4635-B	PT530
F1TZ-4635-C	PT521HD
F2AZ-4635-A	PT521HD
F2AZ-4635-B	PT675
F2AZ-4635-C	PT530
F2AZ-4635-D	PT1204
F2TZ-4635-B	PT530
F3TZ-4635-C	PT1204
F3TZ-4635-A	PT578
F4HZ-4635-A	PT5PL90
F5TZ-4635-A	PT578
F6ZZ-4635-A	PT530
F6ZZ-4635-AA	PT530
GP-18397	PT521HD
GPW-18397	PT521HD
G8T-18397	PT578
LD-44610-A	PT521HD
MEK-7039-A	PT2126
MEK-7042-A	PT2127
MFK-7039	PT521HD
MFK-7039-A	PT521HD
MFK-7039-B	PT521HD
MIK-7039-A	PT2126
O1T-7039	PT578
O1Y-7039	PT521HD
O1Y-18397	PT521HD
SFD 17201T2	PT7102
SFD 901538T2	PT8202
TGAA-4635-A	PT6100
TWAA-4635-A	PT6102
TWAA-4635-B	PT7102
TWAA-4635-D	PT7100
XD-500818	PT515
XL-512825	PT521HD
XY-501497	PT521HD
Z1C-18397	PT521HD
Z1C-18397-B	PT521HD
1M-7039	PT2126
1M-7039-A	PT2126
1M-7042	PT2127
1T-7039	PT578
1Y-7039	PT521HD
7EQ-7039	PT515
8M-7039	PT2126
8M-7042	PT2127
8MTH-7039	PT560
21C-7039	PT521HD
21C-7039-A	PT521HD
107-854	PT6N8

FORD	PTC
145-421	PT35N
148-357	PT12N
171-333	PT6N8
175-423	PT6N8
221-613	PT14N
243-250	PT14N
243-424	PT35N
291-297	PT6N8
291-971	PT6N8
309-575	PT6N8
4050350	PT521HD
4487436	PT521HD

GENERAL MOTORS (Holden, Bedford, Opel)	PTC
45802	PT1750G
45807	PT1750G
100315	PT588
374246	PT578
386451	PT521HD
386452	PT356
390133	PT530
390134	PT3188
419976	PT2127
462809	PT332
509296	PT2127
516405	PT2127
518645	PT521HD
518648	PT521HD
522163	PT3105
535554	PT3105
565987	PT3105
570816	PT356
570817	PT521HD
608194	PT515
609515	PT578
609948	PT578
611934	PT7100
659973	PT7100
661805	PT7102
667501	PT58WB1
667502	PT58WB2
678512	PT524
688016	PT280
694969	PT1206
695232	PT280
695909	PT279
701639	PT281
702129	PT280
703325	PT570
707747	PT515
1181735	PT260
1358938	PT102UJ
1388249	PT530
1389604	PT3188
1389837	PT3188
1389839	PT530
1389865	PT530
1393838	PTCVK5

GENERAL MOTORS (Holden, Bedford, Opel)	PTC
1456525	PT3105
1463548	PT3105
1470373	PT530
1470374	PT3188
1482672	PT530
1604073	PT1750G
2011875	PT6N8
2029986	PT588
2040210	PT407
2041235	PT58WB2
2041472	PT7102
2041859	PT7100
2041860	PT58WB1
2051472	PT7102
2055552	PT281
2057273	PT578
2057289	PT588
2058300	PT280
2066840	PT103UJ
2098536	PT524
2185901	PT560
2186972	PT578
2186973	PT578
2200211	PT6N8
2222853	PT280
2222854	PT279
2223567	PT515
2223568	PT560
2224005	PT524
2230781	PT578
2263882	PT560
2284935	PT515
2294607	PT570
2298621	PT560
2322134	PT515
2322135	PT515
2322136	PT279
2322138	PT280
2325029	PT521HD
2325829	PT521HD
2330781	PT578
2335005	PT524
2335006	PT524
2341648	PT588
2345726	PT588
2354320	PT521HD
2354324	PT515
2362830	PT521HD
2366108	PT280
2370728	PT521HD
2370733	PT280
2386331	PT6N8
2398294	PT58WB1
2398295	PT58WB2
2400938	PT555
2403229	PT565
2403700	PT260
2404877	PT570
2409783	PT260

GENERAL MOTORS (Holden, Bedford, Opel)	PTC
2417789	PT565
2420606	PT6N8
2448100	PT521HD
2448382	PT521HD
2450093	PT578
2460455	PT521HD
2466726	PT6N8
3218621	PT560
3707163	PT578
3707830	PT560
3707891	PT578
3708931	PT578
3708961	PT578
3713926	PT521HD
3724205	PT109UJ
3737508	PT588
3737589	PT588
3741635	PT521HD
3741653	PT521HD
3750686	PT521HD
3780158	PT260
3817179	PT6N8
3823102	PT578
3828469	PT521HD
3830580	PT521HD
3849500	PT521HD
3851520	PT578
3869039	PT6N8
3877040	PT578
3882979	PT107UJ
3889690	PT521HD
3889696	PT578
3910235	PT521HD
3918866	PT6N8
3920486	PT113UJ
3937988	PT530
3953659	PT521HD
3955571	PT521HD
3979617	PT578
3981590	PT260
5671712	PT3105
5675412	PT2127
5675414	PT2127
5675415	PT2127
5677659	PT3105
5698221	PT3188
6258549	PTSCV82
6268535	PT588
6273940	PT297
6342814	PT514
6371722	PT501
6933772	PT9014
7068345	PT501
7068345	PT501
7084449	PT501
7084449	PT514
7088368	PT22GB
7088368	PT22GB
7088370	PT22GB

GENERAL MOTORS (Holden, Bedford, Opel)	PTC
7090700	PT560
7090700	PT560
7156132	PT501
7156132	PT501
7156340	PT501
7156340	PT501
7156385	PT22GB
7178684	PT22GB
7178684	PT22GB
7178934	PT560
7178934	PT560
7190326	PT504
7190326	PT504
7206809	PT279
7206809	PT279
7405065	PT1750G
7421879	PT1750G
7423286	PT1750G
7423287	PT1750G
7806140	PT3105
7808308	PT6N8
7809156	PTCVK1
7810416	108UJ
7814308	PTCVK1
7815848	PTCVK2A
7816006	PTCVK1
7825819	PT350
7826048	PT521HD
7828953	PTCVK2A
7833892	PT3105
7834387	PT578
7840893	PT445
7842007	PT350
8845370	PT521HD
8845379	PT514
8845636	PT501
8871795	PT7100
10147926	PT356
12385742	PT560
12522048	PT578
12543573	PT530
12543576	PT3188
12545626	PT530
12545628	PT3188
12547189	PT578
14034819	PT3188
14046907	PT110UJ
14067677	PT578
14067678	PT521HD
15510800	PT588
15510801	PT588
15515792	PT588
15515793	PT560
15532574	PT281
15535490	PT555
15536284	PT555
15576468	PT530
15577432	PT3188
15580369	PT530

GENERAL MOTORS (Holden, Bedford, Opel)	PTC
15582093	PT530
15583283	PT578
15599179	PT560
15617319	PT455
15617322	PT521HD
15633733	PT6N8
15634912	PT560
15634970	PT578
26001170	PT6N8
26002697	PT3188
26008858	PT445
26015249	PT521HD
26042371	PT3105
26049843	PT578
91021384	PT22GB
94021281	PT514
94027724	PT514
94027819	PT1621
94059482	PT555
94238930	PT1621
94326273	PT1621
94332683	PT1621
94335589	PT1621
94479054	PT1621
96058353	PT1601
96063533	PT1601
97020279	PT521HD
97071811	PT1621
97071812	PT1621
97081330	PT560
97714891	PTSPL90
678510B	PT524
TB94402	PT1750G
X47259	PT280

GMB	PTC
2650121	102UJ
210-0105	PT1750G
210-0134	PT534
210-0153	PT521HD
210-0160	PT560
210-0178	PT578
210-0260	PT260
210-0278	PT521HD
210-0297	PT297
210-0332	PT332
210-0433	PT495
210-0443	PT456
210-0456	PT456
210-1200	PT1200
210-1201	PT675
210-1203	PT1203
210-1204	PT1204
210-1206	PT1206
210-1301	PT373
210-1306	PT266
210-1309	PT231
210-2011	PT2127

GMB	PTC
210-2173	PT2173
210-2500	PT2500
210-3009	PT3188
210-3105	PT3105
211-0297	PT497
211-1306	PT233
215-0012	PT1616
215-0017	PT1619
215-0027	PT1603
215-0029	PT1602
215-0134	PT534
215-0153	PT521HD
215-0178	PT578
215-0260	PT260
215-0297	PT297
215-0356	PT356
215-0358	PT358
215-1200	PT1200
215-1201	PT675
215-1203	PT1203
215-1204	PT1204
215-1306	PT266
215-1307	PT233
215-1309	PT231
215-2500	PT2500
215-3105	PT3105
220-0006	PT1610
220-0007	PT1606
220-0009	PT1622
220-0010	PT1623S
220-0011	PT1604
220-0012	PT1616
220-0013	PT1605
220-0014	PT1617
220-0020	PT1620
220-0021	PT1619
220-0027	PT1603
220-0029	PT1602
220-0052	PT1621
220-0081	PT1601
220-0088	PT1625
220-0098	PT521HD
220-0500	PT501
220-1100	PT504
260-0266G3	106UJ

INT'L HARVESTER (HOUGH/DRESSER)	PTC
20713	PT501
65-343-R91	PT2126
65-345-R91	PT2126
65-351-R93	PT6100
69-557-R93	PT8200
71-783-C1	PT7102
73-551-R93	PT6100
74-289-R91	PT560
75-351-R93	PT6100
77-979-R91	PT2127
78-020-R91	PT2126

INT'L HARVESTER (HOUGH/DRESSER)	PTC
79-557-R92	PT8200
85-351-R91	PT6100
93-326-C1	PT5108
102-684-R91	PT7100
110-859-R91	PT2127
110-860-R91	PT2126
118-122	PT7100
118-122-H1	PT7100
118-123	PT8202
118-123-H1	PT8202
121-345-R91	PT578
121-406-R91	PT521HD
121-684-R92	PT279
121-762-R92	PT280
122-188	PT7105
122-188-H1	PT7105
124-645-R91	PT7100
126-815	PT6102
126-815-H1	PT6102
126-819	PT6100
1266-819-H1	PT6100
127-002	PT8200
127-002-H1	PT8200
127-019	PT8201
127-019-H1	PT8201
127-573-R91	PT578
127-574-R91	PT560
133-137-C91	PT588
133-508HB	PT5110
133-508HC	PT5110
135-764	PT4113
135-764-H1	PT4113
135-465	PT6106
135-765-H1	PT6106
135-766	PT8105
135-766-H2	PT8105
136-142	PT7105
136-142-H1	PT7105
136-488H	PT5100
136-488-HA	PT5100
136-512H	PT7100
136-512HA	PT7100
136-512-HB	PT7100
137-100H	PT6100
139-764	PT6N8
140-604-R92	PT7102
142-133-C1	PT5108
142-136-C1	PT6106
142-823-R91	PT3105
142-923-R91	PT3105
142-973-R91	PT3105
147-511	PT6N8
147-512	PT6N8
149-318	PT2116
149-318-H1	PT2116
150-635-R92	PT6N8
152-227-R92	PT8202
152-275-R91	PT8200
152-276-R92	PT8202

INT'L HARVESTER (HOUGH/DRESSER)	PTC
153-915-H1	PT521HD
154-073	PT588
154-073-H1	PT588
154-081	PT578
154-081-H1	PT578
154-926-R91	PT260
157-794-R91	PT2127
158-746-H1	PT555
158-900	PT5100
158-900-H1	PT5100
159-900	PT5100
159-900-H1	PT5100
161-850-H1	PT4140
175-045	PT7105
175-045-H1	PT7105
176-297-H1	PT578
177-428	PT8200
177-428-H1	PT8200
179-867-H1	PT55N
184-843-H5	PT9031
186-874-R91	PT1200
186-894-R91	PT1200
187-908	PT8105
187-908-H1	PT8105
196-343	PT9031
196-343-H1	PT9031
197-035-R91	PT6N8
197-603	PT6106
197-603-H1	PT6106
198-507	PT6106
198-507-H1	PT6106
200-464-C91	PT14N
202-339-H1	PT58WB
202-347-C91	PT6N8
202-348-C91	PT6N8
203-787-H1	PT501
203-791-H1	PT560
208-959-R91	PT570
213-882-R91	PT555
216-448-H1	PT9031
217-938-H1	PT6N8
226-800-R91	PT588
237-899-R91	PT7100
238-075-R91	PT6100
238-077-R91	PT7100
238-079-R91	PT8200
238-386-R91	PT8202
238-448-R91	PT6100
238-449-R91	PT7100
238-450-R91	PT8200
238-796-R91	PT5100
238-797-R91	PT5110
238-798-R91	PT5110
239-723-R91	PT280
240-178-R91	PT555
240-190-R91	PT555
255-341-R91	PT7100
259-770-R93	PT7105
271-421-R91	PT8105

INT'L HARVESTER (HOUGH/DRESSER)	PTC
279-470-R92	PT6106
279-986-R91	PT5102
290-312-C91	PT260
290-928-R91	PT5100
296-596-R91	PT5100
301-587-R91	PT9031
301-592-R91	PT8105
302-725-C91	PT8200
302-726-C91	PT8202
303-294-R91	PT9031
303-852-R91	PT8105
304-105-R91	PT9031
304-106-R92	PT8105
304-608-C91	PT9014
304-609-C91	PT9017
305-852-R91	PT8105
305-952-R91	PT8105
307-949-R91	PT35N
317-712-R92	PT5102
317-721-R91	PT5111
317-722-R91	PT5110
321-291-R91	PT524
321-485-R91	PT2127
321-921-R91	PT524
324-550-R91	PT9031
324-667-R91	PT8105
325-326-R91	PT6102
327-204-R92	PT6102
328-592-C91	PT521HD
337-439-R91	PT6N8
338-412-R91	PT7105
338-591-R91	PT8105
338-799-R92	PT524
347-385-R91	PT280
347-960-R91	PT35N
350-254-R91	PT6N8
357-439-R91	PT6N8
357-606-R91	PT6N8
357-607-R91	PT6N8
358-412-R91	PT7105
363-308-R91	PT6N8
363-312-R91	PT6N8
363-313-R91	PT6N8
366-312-R91	PT6N8
366-313-R91	PT6N8
368-730-R91	PT6N8
376-892-C91	PT7100
387-097-R91	PT588
399-040-C91	PT6N8
416-946-C91	PT7100
422-910-C91	PT281
427-804-C91	PT260
432-433-C91	PT9014
432-473-C91	PT6N8
447-797-C91	PT570
453-999-R91	PT3105
470-077-R91	PT55N
474-792-R91	PT2127
474-793-R91	PT2127

INT'L HARVESTER (HOUGH/DRESSER)	PTC
476-674-R91	PT6N8
509-047-R91	PT14N
511-644-R91	PT6N8
561-452-C91	PT6N8
569-047-R91	PT14N
581-954-R91	PT2127
607-917-R91	PT14N
609-144-R91	PT12N
613-471-R91	PT35N
613-630-C91	PT6102
613-878-C91	PT6102
615-155-C91	PT6102
630-389-C91	PT7105
631-042-C93	PT6106
631-934-C91	PT7102
634-362-C91	PT524
634-539-C91	PT280
644-137-C91	PT565
645-573-R91	PT521HD
645-574-R92	PT578
645-578-R91	PT521HD
647-869-R93	PT515
656-222-R91	PT3105
656-223-R92	PT2127
659-262-R91	PT12N
660-116-R91	PT35N
661-372-R91	PT6N8
661-677-R91	PT6N8
663-120-R91	PT6N8
667-496-R91	PT14N
667-558-R91	PT14N
669-564-R91	PT12N
682-597-R91	PT588
697-689-R91	PT279
697-690-R91	PT280
698-997-R91	PT9014
702-952-C91	PT9031
751-762-C91	PT565
753-931-R91	PT3105
867-635-C91	PT555
870-638-R91	PT8202
871-280-R91	PT2140
875-952-C91	PT6106
875-952-H1	PT6106
878-624-C91	PT560
881-908-C91	PT5108
886-759-R91	PT521HD
886-890-R91	PT578
886-919-R91	PT560
896-057-C1	PT9014
899-392-R91	PT565
913-774-R91	PT588
925-397-C91	PT7100
965-620-R91	PT588
965-621-R91	PT555
967-379-R91	PT578
974-180-R93	PT524
974-446-R1	PT578
974-499-R91	PT501

INT'L HARVESTER (HOUGH/DRESSER)	PTC
975-663-R91	PT570
983-268-R91	PT6N8
983-922-R91	PT514
1110-935-C91	PT7105
1111-731-C91	PT9031
1111-793-C91	PT6106
1200-046-H91	PT5102
1221-486-H1	PT560
1232-393-H1	PT8105
1232-394-H1	PT8105
1261-950-H91	PT6106
1277-256-C1	PT332
1287-712-C1	PT332
1658-880-C91	PT280HR
1961-779-C1	PT588
3100-758-R91	PT504

MASSEY-FERGUSON	PTC
195379M91	PT55N
316726M91	PT6N8
665137M91	PT14N
830962M91	PT12N
835501M91	PT35N
835512M91	PT3105
835727M91	PT560
835771M91	PT570
835790M91	PT14N
835799M91	PT14N
835991M91	PT35N
836413M91	PT6106
836616M91	PT6106
836664M91	PT6102
836666M91	PT7102
836666M92	PT7102
836667M91	PT7105
836668M91	PT7105
836775M91	PT7102
836775M92	PT7102
836776M91	PT7100
836776M92	PT7100
836891M91	PT6N8
836947M91	PT6106
836948M91	PT6106
837372M91	PT6106
840302M92	PT2126
840303M92	PT2127
840824M91	PT6N8
840824M92	PT6N8
840899M91	PT35N
840899M92	PT35N
841193M91	PT6N8
841193M92	PT6N8
841235M91	PT55N
841236M91	PT12N
841237M91	PT14N
841603M91	PT12N
841604M91	PT14N

MASSEY-FERGUSON	PTC
1016245M91	PT3105
1029144M91	PT5110
1029148M91	PT5111
1052614M91	PT7105
1052619M91	PT6106
1087314M91	PT6102
1089666M91	PT35N
1091060M91	PT515
1091075M91	PT7100
1094925M91	PT5102
1421352M1	PT6106
1423444M1	PT521HD
1429021M1	PT578
3310344M91	PT521HD
3310490M91	PT504
3427330M91	PT578
3427346M91	PT504
3427352M91	PT521HD
3475808M1	PT521HD

MCQUAY-NORRIS	PTC
U01-29HD	521HD
U03-46	10-4-22
U03-47	10-4-133
U03-48	10-4-23
U03-49	10-4-43
U03-50	10-4-12
U03-51	10-4-53
U03-52	10-4-63
U03-53	10-4-163
U03-54	10-4-52
U03-55	10-4-83
U03-56	10-4-93
U03-57	10-4-163
U03-58	10-4-143
U03-59	10-4-113
U03-60	10-4-153
U03-61	10-4-183
U03-62	10-4-193
U03-63	10-3-13
U03-64	10-3-23
U03-65	10-3-22
U03-66	10-3-33
U03-67	10-3-32
U03-68	10-3-32
U03-69	10-3-51
U03-70	10-4-723
4	PT504
74	PT574
100	PT1750G
101	PT501
105	PT1750G
111	PT514
134	PT534
153	PT521HD
160	PT560
178	PT578
212	PT3188
248	PT248

MCQUAY-NORRIS	PTC
260	PT260
297	PT297
332	PT332
350	PT350
353	PT353
354	PT356
357	PT357
443	PT315
456	PT456
460	PT358
467	PT521HD
521	PT530
527	PT360
539	PT353
541	PT3188CC
1200	PT1200
1201	PT675
1203	PT1203
1204	PT1204
1205	PT1750G
1206	PT1206
1301	PT373
1306	PT266
1309	PT231
1312	PT352
1500	PT1604
1501	PT1603
1502	PT1605
1503	PT1601
1504	PT1606
1505	PT1602
1507	PT1610
1508	PT1616
1509	PT1617
1510	PT1619
1511	PT1620
1513	PT1622
1514	PT1623
1515	PT1621
1516	PT1625
1520	PT2500
2011	PT2127
2031	PT2126
2140	PT2140
2173	PT2173
2530	PT2530
3022	PT356
3147	PT3105
3163	PT355
9100	PTSCV76
9101	PTSCV41
9103	PTCVK1
9104	PTCVK1
9108	PTCVK5
9109	PTSCV79
9112	PTSCV42
9119	PTCVK2A
9182	PTSCV82
9418	PT103UJ
9428	PT102UJ
9458	PT105UJ

MCQUAY-NORRIS	PTC
9718	PT107UJ
9728	PT113UJ
9738	PT106UJ
9748	PT108UJ
1306-1	PT233
1510-1	PT1619
260-1	PT496
297-1	PT497
433-1	PT495
544U	PT356
U01-1	PT1750G
U01-10	PT501
U01-12	PT1750G
U01-13	PT504
U01-19	PT266
U01-21	PT3105
U01-28	PT3188
U01-28CC	PT3188CC
U01-29	PT521HD
U01-29CC	PT521HD
U01-29HD	PT495
U01-30	PT574
U01-31CC	PT530
U01-35	PT534
U01-36	PT231
U01-37	PT675
U01-38	PT1204
U01-39	PT1203
U01-4	PT2127
U01-40	PT1604
U01-41	PT1603
U01-42	PT1605
U01-43	PT1601
U01-44	PT1606
U01-45	PT1602
U01-46	PTCVK1
U01-47	PTCVK2A
U01-55	PT353
U01-6	PT2500
U01-64	PT350
U01-66	PT1200
U01-7	PT2530
U01-75	PT353
U01-76	PT356
U01-76CC	PT356
U01-77	PT356
U01-78	PT358
U01-79	PT355
U01-8	PT2173
U01-80	PT1625
U01-81	PT456
U01-82	PT1623
U01-83	PT1622
U01-85	PT1616
U01-86	PT1621
U01-9	PT514
U01-90	PT1620
U02-1	PT2140
U02-10	PT560
U02-12	PT1750G
U02-13	PT1206

MCQUAY-NORRIS	PTC
U02-19	PT373
U02-3	PT233
U02-33	PT1619
U02-34	PT1610
U02-35	PTSCV82
U02-36	PT357
U02-37	PT332
U02-5	PT260
U02-6	PT297
U02-6HD	PT497
U02-7	PT578
U04-23	PT102UJ
U04-24	PT103UJ
U04-26	PT105UJ
U04-27	PT106UJ
U04-28	PT107UJ
U04-29	PT108UJ

MOTOR MASTER	PTC
1587-A	PT6N8
1587-P	PT6N8
2025-A	PT1750G
2060-C	PT2126
2060-D	PT2127
2060-HA	PT2126
2060-V	PT2500
2060-VF	PT2530
2060-W	PT2140
2060-WF	PT2173
2060-XE	PT2116
2060-Y	PT2116
2060-YA	PT2116
2060-YB	PT2116
2060-YD	PT2116
2119-A	PT315
2125-A	PT248
2125-BE	PT248
2207-A	PT570
2207-AS	PT570
2207-P	PT570
2225-B	PT514
2225-BLB	PT501
2225-C	PT501
2225-D	PT514CL
2225-E	PT456
2225-ELB	PT315
2225-G	PT501
2225-W	PT248
2226-A	PT1750G
2226-B	PT1750G
2275-B	PT504
2275-C	PT504
2290-A	PT521HD
2290-D	PT1201
2297-A	PT521HD
2297-AU	PT521HD
2387-E	PT266
2387-EA	PT233

MOTOR MASTER	PTC
2387-EC	PT266
2387-EHP	PT266
2387-ELB	PT233
2387-F	PT267
2387-FHP	PT267
2525-A	PT12N
2531-A	PT12N
2537-A	PT14N
2593-A	PT35N
279X	PT279
2800-A	PT1604
2800-ALB	PT1604
2800-B	PT1623
280X	PT280
281X	PT281
2825-A	PT1603
2825-ALB	PT1603
2825-ALB2	PT1603
2825-B	PT1605
2825-C	PT1601
2825-D	PT1606
2852-A	PT1622
2872-A	PT1621
2875-A	PT1625
2875-B	PT1619
2875-BCL	PT1619
2875-BL	PT1619
2875-BLB	PT1619
2887-A	PT1602
2887-B	PT1616
2887-C	PT1617
2887-D	PT1610
3031-2B	PT3105
3031-B	PT3105
3031-BHP	PT3105
3031-BLB	PT3105
3031-V	PT3188
3031-VCC	PT3188CC
3100-A	PT353
3100-B	PT353
3100-C	PT353
3130-A	PT356
3130-C	PT356
3131-A	PT354
3133-A	PT355
3133-B	PT352
3133-C	PT360
3137-B	PT362
3137-C	PT3188
3140-B	PT358
3140-BLB	PT358
3140-C	PT402
3140-D	PT366
3140-F	PT358
3175-A	PT370
3187-B	PT348
3190-A	PT357
3200-A	PT521HD
3200-ACC	PT521HD
3200-AHP	PT521HDP
3200-AJ	PT521HD

MOTOR MASTER	PTC
3200-ALB	PT495
3200-ALBP	PT495
3200-B	PT521HDU
3200-C	PT574
3200-D	PT260
3200-DLB	PT496
3200-E	PT350
3200-F	PT521HD
3200-G	PT521HD
3210-A	PT297
3210-ALB	PT497
3237-A	PT530
3237-ACC	PT530
3237-B	PT1203
3237-C	PT3188
3240-A	PT578
3240-ACC	PT578
3240-AF	PT578
3240-AHP	PT578
3240-ALB	PT498
3240-B	PT578
3240-C	PT578
3240-D	PT578
3275-AE	PT534
3287-A	PT588
3287-AF	PT588
3287-AXL	PT588
3287-AXL	PT588
3287-C	PT332
3287-CLB	PT332
3290-A	PT560
3290-AF	PT560
3290-B	PT560
3290-C	PT560
3290-D	PT560
3331-A	PT231
3331-AHP	PT231
3331-ALB	PT231
3400-B	PT675
3400-BHP	PT675
3400-BHP	PT675
3437-A	PT1205
3437-C	PT1204
3437-CHP	PT1204
3437-CLB	PT1204
3437-DLB	PT1203
3475-A	PT1202
3493-A	PT1206
3575-B	PT44N
3834-A	PT1620
4000-1E	PT4113
4000-1P	PT4140
4000-E	PT4113
4000-P	PT4110
4025-A	PT5100
4025-ALFL	PT5100
4025-B	PT5108
4025-BLFL	PT5108
4025-E	PT5102
4025-FA	PT5101
4025-G	PT5111

MOTOR MASTER	PTC
4025-GH	PT5111
4025-S	PT5110
407X	PT407
4100-A	PT345
4165-A	PT220
4165-B	PT221
4165-C	PT328
4165-D	PT329
4225-A	PT515
4225-AF	PT515
4225-B	PT22GB
4265-A	PT555
4265-AF	PT555
4300-A	PT373
4465-A	PT555
4575-B	PT58WB1
4575-C	PT58WB2
4575-D	PT58WB
4575-D2	PT58WB
5025-A	PT6100
5025-ALFL	PT6100
5025-ALFL	PT6102
5025-B	PT6106
5025-BAC	PT6106
5025-BLFL	PT6106
5025-G	PT6101
5025-J	PT6102
5050-A	PT7100
5050-ASLFL	PT7100
5050-CA	PT7102
5050-CA4	PT7102
5050-DA	PT7105
5050-DAD	PT7105
5050-DALFL	PT7105
5050-MO	PT7105
5100-AG	PT279HR
5100-AGD	PT279HRK
5118-B	PT331
5178-BG	PT280HR
5178-BGD	PT280HRK
5200-AG	PT279
5218-A	PT565
5278-ADR	PT280
5278-AG	PT280
5278-AG4	PT280
5278-AGS	PT280
5278-ODG	PT280
6000-B	PT8502
6228-AG	PT524
6228-AGF	PT524
6269-A	PT407
6269-ADR	PT407
6269-AGS	PT407
6269-BG	PT407HR
6269-BGD	PT407HRK
7075-A	PT8200
7075-B	PT8105
7075-F	PT8201
7075-G	PT8202
7075-G4	PT8202
7075-H	PT9014

MOTOR MASTER	PTC
7075-HB	PT9031
7075-HBD	PT9031
7075-HBG	PT9031
7075-HBGW	PT9031
7075-HBGWD	PT9031
7075-HBSS	PT9031
7075-HBW	PT9031
7075-HD	PT9017
7075-J	PT8203
7144-A	PT324
7159-A	PT9031
7225-ADR	PT281
7225-AG	PT281
7225-AGS	PT281
7225-BG	PT281HR
7225-BGD	PT281HRK
7244-DC	PT326

NEAPCO	PTC
1-0005	PT504
1-0011	PT1604
1-0012	PT1616
1-0013	PT1605
1-0014	PT1617
1-0023	106UJ
1-0024	107UJ
1-0025	108UJ
1-0027	PT1603
1-0028	PT1604
1-0029	PT1602
1-0029BF	PT1602
1-0045	PT111UJ
1-0046	PT112UJ
1-0089	PT102UJ
1-0099	PT103UJ
1-0105	PT1750G
1-0109	PT109UJ
1-0134	PT534
1-0134BF	PT534
1-0153	PT521HD
1-0153BF	PT521HDSJ
1-0154	PT495
1-0170	PT570
1-0174	PT260
1-0174BF	260SJ
1-0175	PT496
1-0189	PT105
1-0200	PT521HD
1-0221	PT514
1-0248	PT248
1-0278	PT521HD
1-0297	PT297
1-0297BF	497SJ
1-0298	PT497
1-0300	PT514
1-0301	PT501
1-0350	PT350
1-0421	PT504
1-0443	PT315
1-0443BF	315SJ

NEAPCO	PTC
1-0458	PT456
1-1275	PT12N
1-1475	PT6N8
1-1516	PT1625
1-1555	PT1750G
1-1557	PT1601
1-1606	PT1606
1-1608	PT1622
1-1610	PT1610
1-1612	PT1619
1-1612BF	1619SJ
1-1875	PT2127
1-2075	PT14N
1-2173	PT2173
1-2185	PT2116
1-3600	PT2127
1-4635	PT675
1-5800	PT2500
1-5900	PT1200
1-5900BF	1200SJ
1-6300	PT233
1-6301	PT266
1-6301BF	233SJ
2-0020	PT1620
2-0053	PT578
2-0053BF	578SJ
2-0054	PT560
2-0383	PT1621
2-0456	PT456
2-0456BF	456SJ
2-0527	PT360
2-1153	PT366
2-1175	PT231
2-1569	PT3188
2-2157	PT2126
2-2169	PT2126
2-2230	PT2116
2-2275	PT35N
2-2276	PT35N
2-3010	PT3105
2-3011	PT3105
2-3011BF	3105SJ
2-3012	PT3105
2-3100	PT353
2-3111	PT3105
2-4800	PT1203
2-4800BF	1203SJ
2-4801	PT1203
2-4900	PT1204
2-4900BF	1204SJ
2-6302	PT266
2-6600	PT1206
2-9201	PTCVK-1
2-9203	PTCVK-3
2-9205	PTCVK-5
2-9301	PTCVK-2
2-9302	PTCVK-2A
2-9303	PTCVK-4
2-9305	PTCVK-6
3-0044	PT44N
3-0045	PT55N
3-0055	PT22GB

NEAPCO	PTC
3-0056	PT373
3-0155	PT555
3-0188	PT588
3-0332	PT332
3-0621	PT578
3-0821	PT588
3-3130	PT356
3-3140	PT358
3-4143	PT4113
3-5132	PT5110
3-6700	PT588
3-6800	PT555
4-0165	PT565
4-0279	PT279
4-2791	PT279HR
4-5122	PT5100
4-5177	PT5108
4-5262	PT5108
4-5800	PT58WB
4-5801	PT58WB1
4-5802	PT58WB2
4-6114	PT6102
4-6128	PT6106
4-6143	PT6100
4-6937	PT6106
5-0280	PT280
5-2801	PT280HR
5-7126	PT7105
5-7205	PT7100
5-7956	PT7105
6-0124	PT524
6-0281	PT281
6-0324	PT324
6-0407	PT407
6-2811	PT281HR
6-4071	PT407HR
6-8113	PT8105
6-8205	PT8200
6-8207	PT8202
6-9014	PT9014
6-9016	PT9031
6-9017	PT9017
6-9500	PT9031
7-0041	PTSCV-41
7-0042	PTSCV-42
7-0079	PTSCV-79
7-0081	PTSCV-82A
7-0082	PTSCV-82
7-0088	PTSCV-88

PRECISION	PTC
1397	2-4-533
1510	10-4-373
1512	10-4-13
1512	10-4-133
1513	10-4-173
1513	10-4-43
1516	10-4-253
1516	10-4-453
1517	10-4-33
1518	10-4-63

PRECISION	PTC
1519	10-4-73
1520	10-4-643
1521	10-4-573
1522	10-4-493
1522	10-4-93
1523	10-4-443
1525	10-4-163
1526	10-4-113
1527	10-4-103
1527	10-4-143
1528	10-4-153
1529	10-4-193
1530	10-4-123
1534	10-4-22
1535	10-4-23
1537	10-4-12
1537	10-4-62
1539	10-4-52
1540	10-4-32
1541	10-4-101
1542	10-4-11
1544	10-4-21
1545	10-4-31
1546	10-4-53
1548	10-4-83
1552	10-4-183
1553	10-4-293
1560	10-4-282
1567	10-4-481
1700	10-4-693
1702	10-4-713
1703	10-4-703
1704	10-4-683
1705	10-4-723
1750	10-3-13
1751	10-3-23
1752	10-3-33
1754	10-3-83
1755	10-3-183
1756	10-3-163
1763	10-3-81
1765	10-3-51
1766	10-3-32
1772	10-3-162
229	PT1200SJ
230	PT675
231	PT578SJ
232	PT578SJ
233	PT1203SJ
234	PT3105SJ
235	PT3105SJ
237	PT456SJ
240	PT315SJ
245	PT266
246	PT233SJ
248	PT231
250	PT1200SJ
253	PT534
254	PT530SJ
255	PT675
260	PT1203SJ
264	PT1204SJ

PRECISION	PTC
265	PT1204SJ
269	PT521HD
270	PT530SJ
275	PT534
280	PT521HDSJ
285	PT1619SJ
287	PT1619SJ
290	PT3188
304	PT373
315	PT266
315G	PT266
316	PT231
317	PT233
318-10	PT106UJ
319	PT353
320	PT320
329	PT521HD
329-10	PT102UJ
330	PT560
330-10	PT103UJ
331	PT578
331AG	PT578
331-10	PT110UJ
332	PT515
333	PT279
334	PT280
335	PT524
338	PT570
340	PT501
341	PT514
341AG	PT514CL
342	PT514
344	PT504
344AG	PT504
347	PT360
348	PT358
351	PT588
351AG	PT588
351R	PT588
353	PT534
354	PT530
355	PT3188
358	PT555
358-10	PT109UJ
358R	PT555
359	PT565
360-10	PT107UJ
361	PT248
362	PT357
365	PT260
368	PT350
369	PT521HD
369U	PT521HDU
370	PT22GB
371	PT297
372	PT356
374	PT332
375	PT352
376	PT407
377	PT497
378	PT496
379	PT521HD

PRECISION	PTC
380	PT495
381	PT281
383	PT1621
384	PT1610
385	PT1623S
386	PT1622
387	PT1619
389	PT1620
390	PT1616
391	PT1603
392	PT1604
393	PT1602
394	PT1605
395	PT1604
396	PT1617
397	PT1606
398	PT1601
399	PT1625
427	PT1206
429	PT1200
430	PT675
433	PT1203
434	PT1204
436	PT456
437	PT456
437-10	PT107AUJ
437G	PT315
445	PT445
447	PT366
448	PT402
449	PT354
452	PT2116
455	PT455
457	PT457
458	PT362
459	PT459
460	PTSPL90
466	PT456
466	PT315
470	PT221
474	PT220
475	PT279HR
475-10	PT111UJ
476	PT280HR
476-10	PT112UJ
477	PT407HR
478	PT281HR
480	PT324
482	PT7105
484	PT328
488	PT326
492	PT3105
492-10	PT113UJ
497	PT2530
498	PT2173
505	PT2140
507	PT2127
508	PT2126
513	PT2500
514G	PT1750G
515	PT2127
530-10	PT108

PRECISION	PTC
534	PT3105
534-10	PT105
534G	PT3105
550	PT5100
554	PT5110
560	PT6100
561	PT6101
563	PT6102
570	PT7100
574	PT7102
581	PT8200
582	PT8201
583	PT8202
584	PT8203
603	PTCVK-5
604	PTCVK-1
605	PTCVK-1
606	PTCVK-2A
607	PTSCV82
608	PTSCV79
609	PTSCV42
612	PTSCV82A
613	PTSCV34
615	PTSCV41
616	PTSCV76
760	PT6100
763	PT6102
770	PT7100
774	PT7102
781	PT8200
783	PT8202
792	PT9017
793	PT9014
832M	PT266
838	PT570
839	PT6N8
860	PT6N8
861	PT6N8
880	PT14N
882	PT14N
888	PT44N
889	PT55N
894	PT58WB
895	PT58WB1
896	PT58WB2
905	PT6106
911	PT9031
927	PT7105
928	PT8105
929	PT4140
933	PT5102
934	PT35N
952	PT2116
964	PT35N
968	PT5108
969	PT4113
995	PT12N
997	PT5111

ROCKFORD POWERTRAIN	PTC
3-65708	PT2126
3-65745	PT2116
3-65789	PT3105
3-65856	PT4140
3-65863	PT4113
3-65893	PT5100
3-65901	PT5110
3-65903	PT5108
3-65910	PT5111
3-65913	PT5102
3-65970	PT6102
3-65979	PT6106
3-65983	PT6100
3-65990	PT6101
3-66075	PT7105
3-66083	PT7100
3-66087	PT7102
3-66161	PT8105
3-66164	PT8200
3-66166	PT8201
3-66168	PT8202
3-74476	PT5108
3-75937	PT6106
3-75956	PT7105
3-75957	PT8105
3-75999	PT9031
3-76001	PT9017
3-76004	PT9014
3-76871	PT9031
3-80152	PT570
3-80153	PT514
3-80155	PT1200
3-80157	PT1206
3-80158	PT588
3-80159	PT555
3-80160	PT279
3-80161	PT279HR
3-80162	PT565
3-80163	PT280
3-80164	PT280HR
3-80165	PT407
3-80166	PT281
3-80167	PT58WB2
3-80178	PT6N8
3-80179	PT12N
3-80180	PT14N
3-80181	PT35N
3-80731	PT530

ROCKWELL	PTC
L6R-30	PT6N8
L6R-34	PT6N8
L6R-39	PT6N8
L6R-47	PT6N8
170X	PT570
105X	PT1750G
72625-3	PT266
72625-4	PT267
L15N	PT233/PT266
1306-1X	PT233/PT266

ROCKWELL	PTC
1306X	PT266
260-1X	PT496
260X	PT260
297-1X	PT497
297X	PT297
527X	PT360
2011X	PT2127
1200X	PT1200
3022X	PT356
3088	PT3105
3147X	PT3105
1301X	PT373
332X	PT332
1206X	PT1206
101X	PT501
111X	PT514
200X	PT521HD
153X	PT521HD
134X	PT534
460X	PT358
213X	PT530
178X	PT578
160X	PT560
188X	PT588
155X	PT555
165X	PT565
148N	PT588
155N	PT555
248X	PT248
353X	PT353
2140	PT2140
131N1	PT1204
1201X	PT675
133N	PT1203
1204X	PT1204
133N1	PT1204
357X	PT357
141N	PT1206
354X	PT354
2116	PT2116
4143X	PT4113
5122	PT5100
5177	PT5108
5000	PT5100
58WB-DWT	PT58WB1
58WB-HB	PT58WB2
58WB-HWD	PT58WB
62N-DWT	PT6100
68N-HB	PT6102
62N-HWD	PT6106
72N118	PT7102
72N-136	PT7105
72N-DWT	PT7100
72N-HB	PT7102
72N-HWD	PT7105
82N-77	PT9202
82N-DWT	PT8200
82N-HB	PT8202
82N-HWD	PT8105
92N-70	PT9014
92N-DWT	PT9014
92N-HB	PT9017

ROCKWELL	PTC
92N-HWD	PT9031
2031	PT2126
5154	PT5111
5008	PT5110
18N96	PT324
115X	PT515
279X	PT279
16NS	PT279
280X	PT280
17NS	PT280
124X	PT524
407X	PT407
176NS	PT407
281X	PT281
18NS	PT281
438X	PT279HR
515X	PT280HR
469X	PT407HR
510X	PT281HR
16S1	PT279HR
16S2	PT279HRK
17S1	PT280HR
17S2	PT280HRK
176S1	PT407HR
176S2	PT407HRK
18S1	PT281HR
18S2	PT281HRK

SPICER	PTC
2-70-18X	PT107UJ
2-94-28X	PT102UJ
3-70-28X	PT110UJ
3-94-18X	PT103UJ
3-94-28X	PT109UJ
5-100X	PT1750G
5-101X	PT501
5-102X	PT514
5-103X	PT570
5-105X	PT1750G
5-110X	PT570
5-111X	PT514
5-115X	PT515
5-1200X	PT1200
5-1201X	PT675
5-1203X	PT1203
5-1204X	PT1204
5-1206X	PT1206
5-1214X	PT588
5-124X	PT524
5-129-1X	PT14N
5-129X	PT14N
5-1301X	PT373
5-1306-1X	PT233
5-1306X	PT266
5-1309X	PT231
5-1312X	PT352
5-134X	PT534
5-1500-1X	PT1604
5-1500X	PT1604
5-1501X	PT1603
5-1502X	PT1605

SPICER	PTC
5-1503X	PT1601
5-1504X	PT1606
5-1505X	PT1602
5-1507X	PT1610
5-1508X	PT1616
5-1509X	PT1617
5-1510-1X	PT1619
5-1510X	PT1619
5-1511X	PT1620
5-1514X	PT1623
5-1515X	PT1621
5-1516X	PT1625
5-153X	PT521HD
5-155X	PT555
5-160X	PT560
5-165X	PT565
5-170X	PT570
5-178X	PT578
5-188X	PT588
5-200X	PT521HD
5-2011X	PT2127
5-2031X	PT2126
5-2116X	PT2116
5-212X	PT3188
5-213X	PT530
5-2140X	PT2140
5-2173X	PT2173
5-220X	PT220
5-221X	PT221
5-242X	PT12N
5-243X	PT35N
5-248X	PT248
5-251X	PT521HD
5-2530X	PT2530
5-260-1X	PT496
5-260X	PT260
5-263X	PT588
5-279X	PT279
5-280X	PT280
5-281-4X	PT281
5-281X	PT281
5-297-1X	PT497
5-297X	PT297
5-3011X	PT3105
5-3022X	PT356
5-3147X	PT3105
5-3163X	PT355
5-324X	PT324
5-328X	PT328
5-329X	PT329
5-331X	PT331
5-332X	PT332
5-344X	PT534
5-345X	PT345
5-348X	PT348
5-350X	PT350
5-353X	PT353
5-354X	PT354
5-357X	PT357
5-4002X	PT4113
5-407X	PT407
5-4140X	PT4140

SPICER	PTC
5-4143X	PT4113
5-431X	PT44N
5-432X	PT55N
5-433-1X	PT495
5-438X	PT279HR
5-443X	PT315
5-447X	PT578
5-456X	PT456
5-458X	PT315
5-460X	PT358
5-462X	PT1206
5-469X	PT407HR
5-4X	PT504
5-5000X	PT5100
5-5008X	PT5110
5-510X	PT281HR
5-5121X	PT5101
5-515X	PT280HR
5-5177X	PT5108
5-527X	PT360
5-544X	PT1202
5-547X	PT456
5-5800X	PT58WB
5-6000X	PT6100
5-6102X	PT6102
5-6106X	PT6106
5-617X	PT578
5-618X	PT1203
5-619X	PT3188CC
5-621X	PT3188CC
5-625X	PT521HD
5-625X	PT521HD
5-626X	PT521HD
5-626X	PT521HD
5-627X	PT578
5-631X	PT1203
5-632X	PT521HD
5-633X	PT1203
5-634X	PT353
5-635X	PT3188
5-636X	PT231
5-641X	PT1206
5-647X	PT353
5-674X	PT279HRK
5-675X	PT280HRK
5-676X	PT281HRK
5-677X	PT407HRK
5-696X	PT324
5-7000X	PT7100
5-70-28X	PT111UJ
5-7105X	PT7105
5-718X	PT1200
5-718X	PT521HD
5-719X	PT1200
5-7202X	PT7102
5-74X	PT574
5-8105X	PT8105
5-8200X	PT8200
5-8202X	PT8202
5-86X	PT578
5-88X	PT332
5-9001X	PT9031

SPICER	PTC
5-92X	PT6N8
6.5-70-18X	PT112UJ
SPL90X	PTSPL90
SPL170X	PTSPL170
SPL250X	PTSPL250

TOYOTA	PTC
04371-04010	PT521HD
04371-04020	PT521HD
04371-10010	PT1604
04371-10011	PT1604
04371-20010	PT1605
04371-20011	PT1605
04371-22010	PT1605
04371-22011	PT1605
04371-25010	PT1616
04371-30011	PT1616
04371-30020	PT1619
04371-30021	PT1619
04371-30030	PT1619
04371-30040	PT1619
04371-35020	PT1619
04371-35030	PT1619
04371-35031	PT1619
04371-35040	PT1619
04371-35050	PT1619
04371-36010	PT1617
04371-36011	PT1617
04371-36020	PT1620
04371-36021	PT1620
04371-36030	PT1620
04371-60010	PT1617

TRU-CROSS/ PERFECT CIRCLE/	PTC
4	PT504
92	PT6N8
100	PT1750
101	PT501
102	PT514
103	PT570
105	PT1750
110	PT570
111	PT514
115	PT515
124	PT524
129	PT14N
134	PT534
153	PT521HD
155	PT555
158	PT555
160	PT560
165	PT565
170	PT570
178	PT578
178XU	PT578U
188	PT588
200	PT521HD
212	PT3188
213	PT530

TRU-CROSS/ PERFECT CIRCLE/	PTC
220	PT220
221	PT221
237	PT588
242	PT12N
243	PT35N
243-1	PT35N
248	PT248
252	PT521HD
255	PT521HD
260	PT260
260-1	PT496
263	PT588
278	PT521HD
279	PT279
280	PT280
281	PT281
282	PT578
297	PT297
297-1	PT497
299	PT565
324	PT324
328	PT328
332	PT332
350	PT350
353	PT353
354	PT354
355	PT362
357	PT357
407	PT407
419	PT521HD
420	PT521HD
431	PT44N
432	PT55N
433-1	PT495
438	PT279HR
443	PT315
447U	PT578
456	PT456
460	PT358
467	PT521HD
469	PT407HR
510	PT281HR
515	PT280HR
521	PT530
526	PT456
527	PT360
529	PT521HD
538	PT1204
539	PT353
541	PT3188
544U	PT356
648	PT402
1200	PT1200
1201	PT675
1203	PT1203
1204	PT1204
1206	PT1206
1301	PT373
1306	PT266
1306-1	PT233
1309	PT231

TRU-CROSS/ PERFECT CIRCLE/	PTC
1312	PT352
1500	PT1604
1501	PT1603
1502	PT1605
1503	PT1601
1504	PT1606
1505	PT1602
1507	PT1610
1508	PT1616
1509	PT1617
1510	PT1619
1510-1	PT1619
1511	PT1620
1513	PT1622
1514	PT1623S
1515	PT1621
1516	PT1625
1520	PT2500
2011	PT2127
2031	PT2126
2116	PT2116
2140	PT2140
2173	PT2173
2530	PT2530
3011	PT3105
3022	PT356
3147	PT3105
3162	PT366
4140	PT4140
4143	PT4113
5000	PT5100
5008	PT5110
5177	PT5108
5800	PT58WB
5801	PT58WB1
5802	PT58WB2
6000	PT6100
6102	PT6102
6106	PT6106
7000	PT7100
7105	PT7105
7202	PT7102
8105	PT8105
8200	PT8200
8202	PT8202
9000	PT9014
9001	PT9031
9002	PT9017
9100	PTSCV76
9101	PTSCV41
9103	PTCVK-1
9104	PTCVK-1
9108	PTCVK-5
9109	PTSCV79
9112	PTSCV42
9119	PTCVK-2A
9182	PTSCV82
9418	PT103UJ
9428	PT102UJ
9458	PT105UJ
9718	PT107UJ

TRU-CROSS/ PERFECT CIRCLE/	PTC
9728	PT113UJ
9738	PT106UJ
9748	PT108UJ

TRW	PTC
20001	PT6N8
20003	PT1750G
20007	PT2127
20011	PT2500
20012	PT2530
20013	PT2140
20014	PT2173
20016	PT2116
20017	PT570
20021	PT514
20022	PT248
20023	PT504
20030	PT266
20031	PT266
20036	PT12N
20037	PT14N
20038	PT35N
20040	PT3105
20047	PT3188
20049	PT521HD
20054	PT578
20056	PT534
20057	PT588
20058	PT560
20059	PT231
20060	PT1200
20061	PT675
20063	PT1204
20064	PT1203
20066	PT1206
20067	PT588
20073	PT4113
20080	PT5100
20081	PT5108
20082	PT5110
20083	PT5102
20088	PT22GB
20089	PT555
20090	PT373
20092	PT6100
20093	PT6106
20096	PT6102
20099	PT7100
20101	PT7105
20105	PT565
20109	PT8200
20110	PT8105
20112	PT8202
20113	PT9014
20114	PT9017
20115	PT9031
20123	PT2127
20124	PT233
20128	PT1604
20129	PT1603

TRW	PTC
20130	PT1605
20131	PT1601
20134	PT279
20135	PT280
20136	PT524
20137	PT281
20142	PT58WB1
20143	PTCPWB2
20144	PT58WB
20147	PT1616
20167	PT355
20183	PT1602
20184	PT350
20186	PTSCV-82
20187	PT1610
20188	PT332
20189	PT353
20192	PT260
20193	PT297
20199	PT1617
20203	PT44N
20204	PT55N
20214	PT407
20215	PTSCV-79
20216	PT1621
20218	PT1622
20219	PT1619
20220	PT1620
20221	PT1606
20222	PT1625
20223	PT555
20226	PT360
20227	PT358
20228	PT357
20229	PT356
20293	PTSCV-42
20296	PT456
20303	PT324
20306	PT521HD
20313	PT456
20319	PT362
20323	PT352
20324	PT402
20326	PT455
20331	PT504
20333	PTSCV-82A
20343	PT407HR
20346	PT354
20347	PT279HR
20348	PT280HR
20349	PT281HR
20427	PT514
20429	PT578
20430	PT588
20438	PT456
20439	PT1750G
20457	PT1604
20601	10-4-12
20602	10-4-13
20603	10-4-22
20604	10-4-23
20605	10-4-33

TRW	PTC
20606	10-4-43
20607	10-4-53
20608	10-4-63
20609	10-4-73
20611	10-4-83
20612	10-4-93
20613	10-4-103
20614	10-4-113
20615	10-4-183
20616	10-4-123
20617	10-4-153
20630	10-3-12
20631	10-3-13
20632	10-3-22
20634	10-3-32
20635	10-3-33
20636	10-3-83
20637	10-3-81
20638	10-3-51
20646	10-4-713
20693	10-4-22
20701	PT102UJ
20702	PT103UJ
20703	PT105UJ
20704	PT106UJ
20705	PT108UJ
20706	PTSCV-88
20725	PTCVK-1
20726	PTCVK-3
20727	PTCVK-5
20728	PTCVK-2A
20729	PTCVK-2A
20730	PTCVK-4
20731	PTCVK-6
20732	PT107UJ
20737	PT366
20739	PTSCV-41
20741	PT109UJ
20751	PT111UJ
20752	PT112UJ
21000	10-4-373
21001	10-4-43
21003	10-4-12
21004	10-4-282
21005	10-3-162
21009	10-4-52
21010	10-3-122
21011	10-4-113
21014	10-4-32
21016	10-4-153
21017	10-4-183
21017	10-4-123
21042	10-4-43
21049	10-4-93
21132	10-4-93
21310	10-4-293
21318	10-4-93
21321	10-4-123
21339	10-4-123
21343	10-4-183
21676	10-4-63
20030P	PT266

TRW	PTC
20038E	PT35N
20040E	PT3105
20040P	PT3105
20049E	PT495
20049P	PT521HD
20054P	PT578
20056P	PT534
20060P	PT1200
20063P	PT1204
20064E	PT1203
20064P	PT1203
20183P	PT1602
20192E	PT496
20192P	PT260
20193E	PT497
20193P	PT297
20219P	PT1619
20292P	PT315
20435P	PT456