

LT-2022



INDUSTRIAS AUTOMOTRICES



Partes de transmisión
Transmission parts

www.lodi.com.mx

MAX[®]

performance

CABLES PARA BUJIAS

Spark Plug Wire Set



SILICÓN EPS
7 / 8 mm



EPDM
7 / 8 mm



RACING
8.5 mm



www.lodi.com.mx



LODI Industrias Automotrices

Dale Like !



**CATÁLOGO
PARTES DE
TRANSMISIÓN
LT-2022**

	Iniciales	Pag.
POLITICA DE GARANTÍA		3
1 PARTES PARA TRANSMISIÓN		
Información técnica aro automático		4
1.1 Aros dentados transmisión automática	AA	9-35
1.2 Aros dentados transmisión estándar	AS	36-38
1.3 Aros dentados transmisión estándar dimensiones		38-39
Información técnica filtro y empaque de transmisión automática		40-41
1.4 Filtro y empaque de transmisión automática	FC	42-110
1.5 Moduladores	MO	111-112
1.6 Volantes estándar	WOH	113-117
2 PARTES PARA SISTEMA DE EMBRAGUE		
2.1 Horquilla de clutch	HC, SHC	118-123
2.2 Tornillo de horquilla de clutch	THC	124-126
2.3 Maromas y balancines	MOB	126-127
2.4 Tornillo o varilla de ajuste para horquilla de clutch	T	127
2.5 Templadores, ajustes, porta horquillas de clutch y seguros	CAC, PH, M, CHP, SAP, TC	128
3 PIEZAS VARIAS		
3.1 Tuercas para caja de velocidades	TCV, TCM	129-130
4 PARTES PARA EJE TRASERO		
4.1 Arañas, guasas y tuercas de housing	AH,GH,TH,SB,JTA	131-133
5 PARTES PARA BARRA CARDAN		
5.1 Soportes para barra cardan	BC, HS, B, GP	135-143
6 TABLAS DE EQUIVALENCIAS		
6.1 Filtro y empaque de transmisión automática		144-143

Abreviaturas

A	Admisión	D.I.	Diametro interior	N.D.	No disponible	TT	Tracción trasera
CC	Centimetros cubicos	D. Std.	Dirección standard	NR	No requiere	U.D.	Universal Delgada
CID	Cubic Inch displacement	E	Escape	OEM	Original equipment manufacturer	U.G.	Universal Gruesa
Cil.	Cilindros	EC	Estriado completo	TC	Tornillos de carter	VEL.	Velocidades
D.E.	Diametro exterior	EP	Estriado plano	TD	Tracción delantera	N	Nueva Aplicación
D. Hidr.	Dirección hidraulica	L	Litros				



INDUSTRIAS AUTOMOTRICES

GARANTÍA LIMITADA

Nuestras piezas están garantizadas contra defectos de material o fabricación. Se reponen con mercancía equivalente únicamente las piezas que resulten defectuosas.

Nuestra compañía no asume la responsabilidad por daños consecuentes o incidentales bajo ninguna circunstancia. En ningún caso se aceptarán cargos por otros conceptos.

La garantía solamente es válida para nuestros clientes directos.

La información en este catálogo está correcta a nuestro alcance, puesto que ha sido recopilada de fuentes fiables, aun así no nos hacemos responsables por algún posible error en ella.

NOTA: Los números originales mencionados en este catálogo son utilizados únicamente como referencia para facilitar la localización de la refacción, ya que nosotros utilizamos nuestra propia nomenclatura para nuestras piezas.

No se pretende que nuestras piezas pasen como equipo original.

LIMITED GUARANTEE

Our products are guaranteed against defects in material and workmanship. Our obligation is limited to replacement of the defective part.

Our company is not responsible for any incidental or consequential damages which may result. We will not accept any charge.

The guarantee is only given to our direct customers.

The information in this catalog is correct to the best of our knowledge. However, we will not assume any responsibility for any possible error or omission.

NOTE: The original numbers mentioned in this catalog are used only as a reference, we have our numbers replacement parts. There is no intent to represent any part herein as being that of the original equipment manufacturer.

PIONEER®

Automotive Industries

Ahora en México

Más de 65 años de experiencia en EUA

**Soportes de Motor
y Transmisión para
todas las marcas de vehículos**



811 022 4604



Miembro de Grupo LODI

TOP 10 SOPORTES DE MOTOR DE MAYOR PARQUE VEHICULAR

TSURU III (00-07)



606311
Sop. Motor Frontal
Derecho



606331
Sop. de Torsión



629933
Sop. de palanca
de Transmisión



620694
Sop. Trasero



626324
Sop. Transmisión

AVEO (08-17)



615350
Sop. Motor Frontal



625351
Sop. transmisión



635378
Soporte de Torsión

CHEVY (08-17)



622657
Sop. Trasero



609847
Sop. Transmisión



602656
Sop. Motor
Frontal Izquierdo

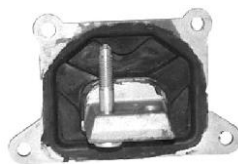

609833
Sop. Motor
Frontal Derecho

NISSAN VERSA (12-19)



619828
Sop. Motor
Frontal Derecho



629678
Sop. Transmisión



639671
Soporte de Torsión

TOP 10 SOPORTES DE MOTOR DE MAYOR PARQUE VEHICULAR

VW POINTER 98-08



606311
Sop. Motor Frontal
Derecho & Izquierdo



629093
Sop. Transmisión

CHEVROLET CORSA (00-08)



609809
Motor Frontal



609807
Sop. de
Torsión



629808
Sop. Transm.



600206
Sop. Trasero



629822
Sop. Trans. Inferior

VW VENTO (11-19)



600900
Sop. Motor Frontal Derecho

CHEVROLET SPARK



615512
Sop. Motor
Frontal Izquierdo



605511
Sop. Transmisión



605521
Soporte de Torsión

TOP 10 SOPORTES DE MOTOR DE MAYOR PARQUE VEHICULAR

NISSAN NP300 (09-15)



608297
Sop. Motor Frontal
Derecho & Izquierdo

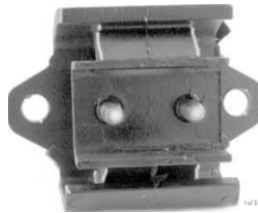

628328
Sop. Transmisión

NISSAN D21 (93-08)



602718
Sop. Motor Frontal
Derecho & Izquierdo

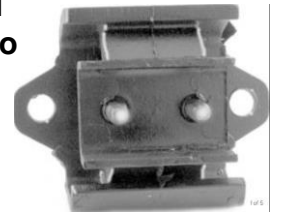

628328
Sop. Transmisión

*Contamos con mas de 3,000
soportes para vehículos
nacionales e importados*

Consulta nuestro catalogo en:

www.lodi.com.mx

¿POR QUÉ SE FRACTURA UN ARO AUTOMÁTICO ALREDEDOR DEL CIGUEÑAL O DE LOS PUNTOS DE APOYO DEL CONVERTIDOR DE TORQUE (TURBINA)?

Los daños en la estructura del aro automático es más a menudo debido a una falla de instalación y/o problemas de balanceo entre el motor y la transmisión.

Cuando esto ocurre, pueden ser varias las causas:

- 1) Falla al instalar el aro automático cuando este no queda completamente perpendicular a la base del cigüeñal.
- 2) Convertidor de torque (turbina) fuera de balance.
- 3) Buje frontal (de la bomba) de la transmisión desgastado.
- 4) Demasiado juego del cigüeñal debido al excesivo desgaste de los cojinetes (metales de cigüeñal).
- 5) Falla por no dar el torque correcto a los tornillos de acuerdo a las y a la secuencia correcta de los mismos.
- 6) Motor de arranque (marcha) en malas condiciones puede causar en los dientes o en el aro dentado un rápido desgaste o ruptura.

7) En algunas aplicaciones de GM, un espaciador especial o *laina* es requerida para alinear correctamente

el motor de arranque con el aro dentado. En tales casos cuando el espaciador es necesario y no fue instalado puede ocurrir daño en el aro dentado.

8) En vehículos de la marca Nissan, el no colocar las guías de la transmisión, ocasiona que se genere una fuerza axial al centro del aro dentado, teniendo como consecuencia que este se estrelle y/o fracture del centro.

TIPS DE IMPORTANCIA

- A) Nunca sobre-torque los tornillos.
- B) Siempre use un torquímetro.
- C) Nunca emplee herramienta neumática para instalarlo.
- D) Procure usar tornillos nuevos al instalar un nuevo aro automático.

Nota: En todo aro dentado que presente este tipo de daño, no procede la garantía.

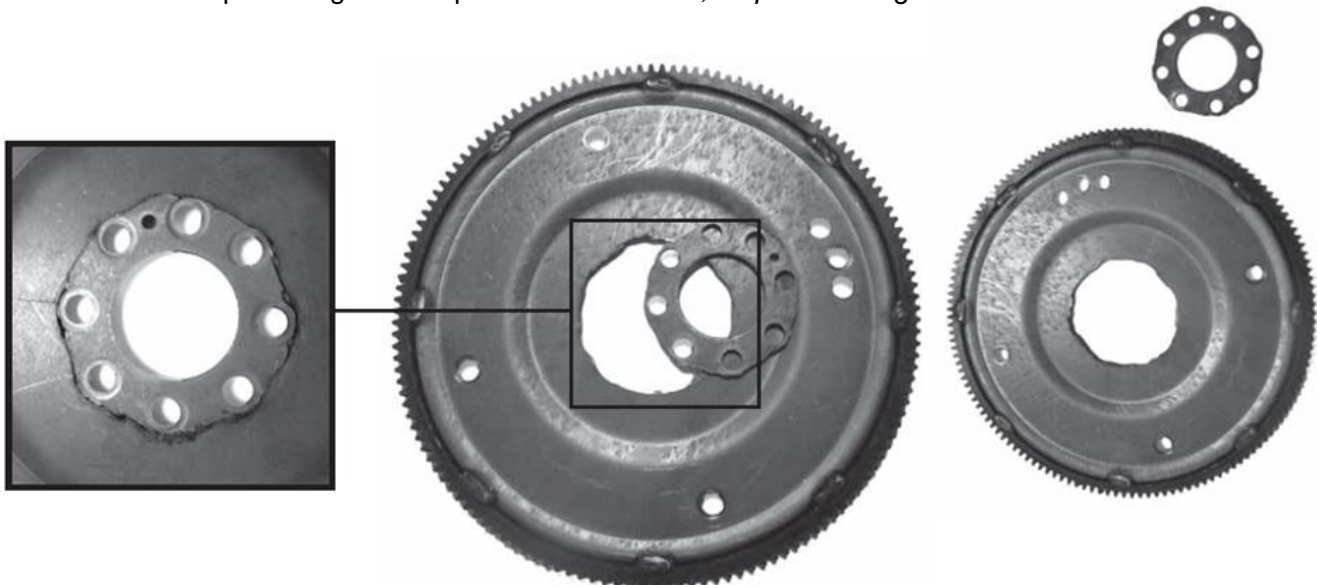











1.1 Aros dentados transmisión automática

Automatic transmission flex plates



American Motor Company / Jeep

 <p>AA-A300</p>	<table border="1"> <tr><td>Dientes</td><td>164</td></tr> <tr><td>Contrapeso</td><td>No</td></tr> <tr><td>Diám Ext.</td><td>13.83"</td></tr> <tr><td>OEM</td><td>3232138</td></tr> <tr><td colspan="2">L6 232, 252, 258 Gremlin, Jeep, Pacer y Rambler (72-88)</td></tr> </table>	Dientes	164	Contrapeso	No	Diám Ext.	13.83"	OEM	3232138	L6 232, 252, 258 Gremlin, Jeep, Pacer y Rambler (72-88)		 <p>AA-A301</p>	<table border="1"> <tr><td>Dientes</td><td>164</td></tr> <tr><td>Contrapeso</td><td>Si</td></tr> <tr><td>Diám Ext.</td><td>13.83"</td></tr> <tr><td>OEM</td><td>3232139</td></tr> <tr><td colspan="2">V8 304, 360 AMC / Jeep (72-87)</td></tr> </table>	Dientes	164	Contrapeso	Si	Diám Ext.	13.83"	OEM	3232139	V8 304, 360 AMC / Jeep (72-87)	
Dientes	164																						
Contrapeso	No																						
Diám Ext.	13.83"																						
OEM	3232138																						
L6 232, 252, 258 Gremlin, Jeep, Pacer y Rambler (72-88)																							
Dientes	164																						
Contrapeso	Si																						
Diám Ext.	13.83"																						
OEM	3232139																						
V8 304, 360 AMC / Jeep (72-87)																							
 <p>AA-A302</p>	<table border="1"> <tr><td>Dientes</td><td>164</td></tr> <tr><td>Contrapeso</td><td>No</td></tr> <tr><td>Diám Ext.</td><td>13.83"</td></tr> <tr><td>OEM</td><td>5351819</td></tr> <tr><td colspan="2">L6 232 y 258 AMC / Jeep (74-79) (excepto Jeeps Serv. Postal USA)</td></tr> </table>	Dientes	164	Contrapeso	No	Diám Ext.	13.83"	OEM	5351819	L6 232 y 258 AMC / Jeep (74-79) (excepto Jeeps Serv. Postal USA)		 <p>AA-A303</p>	<table border="1"> <tr><td>Dientes</td><td>164</td></tr> <tr><td>Contrapeso</td><td>No</td></tr> <tr><td>Diám Ext.</td><td>13.83"</td></tr> <tr><td>OEM</td><td>5351821</td></tr> <tr><td colspan="2">V8 360 AMC / Jeep (74-79) w/TH400</td></tr> </table>	Dientes	164	Contrapeso	No	Diám Ext.	13.83"	OEM	5351821	V8 360 AMC / Jeep (74-79) w/TH400	
Dientes	164																						
Contrapeso	No																						
Diám Ext.	13.83"																						
OEM	5351819																						
L6 232 y 258 AMC / Jeep (74-79) (excepto Jeeps Serv. Postal USA)																							
Dientes	164																						
Contrapeso	No																						
Diám Ext.	13.83"																						
OEM	5351821																						
V8 360 AMC / Jeep (74-79) w/TH400																							
 <p>AA-A305</p>	<table border="1"> <tr><td>Dientes</td><td>164</td></tr> <tr><td>Contrapeso</td><td>No</td></tr> <tr><td>Diám Ext.</td><td>13.83"</td></tr> <tr><td>OEM</td><td>3184926</td></tr> <tr><td colspan="2">V8 360 AMC / Jeep (71-73)</td></tr> </table>	Dientes	164	Contrapeso	No	Diám Ext.	13.83"	OEM	3184926	V8 360 AMC / Jeep (71-73)		 <p>AA-A306</p>	<table border="1"> <tr><td>Dientes</td><td>164</td></tr> <tr><td>Contrapeso</td><td>No</td></tr> <tr><td>Diám Ext.</td><td>13.83"</td></tr> <tr><td>OEM</td><td>3184927</td></tr> <tr><td colspan="2">V8 304 AMC / Jeep (71-73)</td></tr> </table>	Dientes	164	Contrapeso	No	Diám Ext.	13.83"	OEM	3184927	V8 304 AMC / Jeep (71-73)	
Dientes	164																						
Contrapeso	No																						
Diám Ext.	13.83"																						
OEM	3184926																						
V8 360 AMC / Jeep (71-73)																							
Dientes	164																						
Contrapeso	No																						
Diám Ext.	13.83"																						
OEM	3184927																						
V8 304 AMC / Jeep (71-73)																							
 <p>AA-A307</p>	<table border="1"> <tr><td>Dientes</td><td>164</td></tr> <tr><td>Contrapeso</td><td>No</td></tr> <tr><td>Diám Ext.</td><td>13.83"</td></tr> <tr><td>OEM</td><td>5351820</td></tr> <tr><td colspan="2">V8 304 AMC / Jeep (74-79)</td></tr> </table>	Dientes	164	Contrapeso	No	Diám Ext.	13.83"	OEM	5351820	V8 304 AMC / Jeep (74-79)		 <p>AA-A308</p>	<table border="1"> <tr><td>Dientes</td><td>164</td></tr> <tr><td>Contrapeso</td><td>Si</td></tr> <tr><td>Diám Ext.</td><td>13.83"</td></tr> <tr><td>OEM</td><td>5351822</td></tr> <tr><td colspan="2">V8 401 AMC / Jeep (74-78)</td></tr> </table>	Dientes	164	Contrapeso	Si	Diám Ext.	13.83"	OEM	5351822	V8 401 AMC / Jeep (74-78)	
Dientes	164																						
Contrapeso	No																						
Diám Ext.	13.83"																						
OEM	5351820																						
V8 304 AMC / Jeep (74-79)																							
Dientes	164																						
Contrapeso	Si																						
Diám Ext.	13.83"																						
OEM	5351822																						
V8 401 AMC / Jeep (74-78)																							
 <p>AA-A309</p>	<table border="1"> <tr><td>Dientes</td><td>164</td></tr> <tr><td>Contrapeso</td><td>No</td></tr> <tr><td>Diám Ext.</td><td>13.83"</td></tr> <tr><td>OEM</td><td>5900002</td></tr> <tr><td colspan="2">L6 232 AMC / Jeep (72-75) (Jeep del Servicio Postal USA)</td></tr> </table>	Dientes	164	Contrapeso	No	Diám Ext.	13.83"	OEM	5900002	L6 232 AMC / Jeep (72-75) (Jeep del Servicio Postal USA)		 <p>AA-A310</p>	<table border="1"> <tr><td>Dientes</td><td>164</td></tr> <tr><td>Contrapeso</td><td>No</td></tr> <tr><td>Diám Ext.</td><td>13.83"</td></tr> <tr><td>OEM</td><td>33004359</td></tr> <tr><td colspan="2">L6 258 AMC / Jeep Wrangler (87-90)</td></tr> </table>	Dientes	164	Contrapeso	No	Diám Ext.	13.83"	OEM	33004359	L6 258 AMC / Jeep Wrangler (87-90)	
Dientes	164																						
Contrapeso	No																						
Diám Ext.	13.83"																						
OEM	5900002																						
L6 232 AMC / Jeep (72-75) (Jeep del Servicio Postal USA)																							
Dientes	164																						
Contrapeso	No																						
Diám Ext.	13.83"																						
OEM	33004359																						
L6 258 AMC / Jeep Wrangler (87-90)																							

1.1 Aros dentados transmisión automática

Automatic transmission flex plates



American Motor Company / Jeep

	AA-A311	Dientes	164
		Contrapeso	Si
		Diám Ext.	13.83"
		OEM	33004361
	V8 360 AMC / Jeep Grand Wagoneer (88-91)		

	AA-A312	Dientes	164
		Contrapeso	Si
		Diám Ext.	13.83"
		OEM	3232141
	V8 401 AMC (72-76)		

	AA-A313	Dientes	164
		Contrapeso	No
		Diám Ext.	13.83"
		OEM	5351485
	L6 232 y 258 AMC / Jeep (71-73) (excepto Jeeps Serv. Postal USA)		

	AA-A314	Dientes	148
		Contrapeso	Si
		Diám Ext.	12.40"
		OEM	53001255
	V6 173 AMC / Jeep (84-86) (motor Chevrolet)		

	AA-A315	Dientes	148
		Contrapeso	No
		Diám Ext.	12.50"
		OEM	33002842
	L4 150 (2.5L) Eagle Premier (88-89)		

	AA-A316	Dientes	164
		Contrapeso	No
		Diám Ext.	13.83"
		OEM	33002675
	L6 242 (4.0L) Jeep Cherokee, Comanche (87-90)		

	AA-A317	Dientes	148
		Contrapeso	No
		Diám Ext.	12.40"
		OEM	53001184
	L4 150 (2.5L) Jeep Cherokee, CJ7 (83-85) (motor Jeep)		

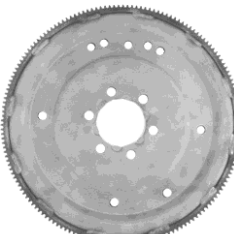
	AA-A318	Dientes	164
		Contrapeso	No
		Diám Ext.	13.83"
		OEM	52117761 / 52118551 53006324
	L6 4.0L Jeep Cherokee, Wrangler, Grand Cherokee (91-96)		

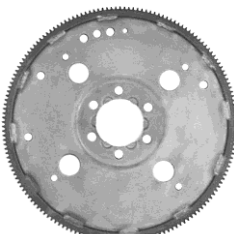
	AA-A319	Dientes	164
		Contrapeso	No
		Diám Ext.	13.83"
		OEM	53006328
	L6 4.0L Jeep Grand Cherokee (93-95), Jeep Wrangler (91-04)		









	AA-A320	Dientes	164
		Contrapeso	No
		Diám Ext.	13.83"
		OEM	52118257
	L6 4.0L Jeep Cherokee, Grand Cherokee (97-03) (turbina 90°)		

1.1 Aros dentados transmisión automática

Automatic transmission flex plates

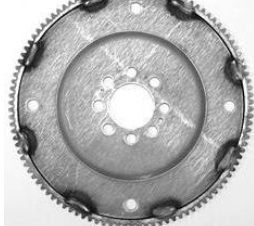

Chrysler / Dodge









 <p>AA-C400</p>	<table border="1"> <tr><td>Dientes</td><td>139</td></tr> <tr><td>Contrapeso</td><td>No</td></tr> <tr><td>Diám Ext.</td><td>11.75"</td></tr> <tr><td>OEM</td><td>4736016</td></tr> <tr><td colspan="2">V6 2.5L, 3.3L, 3.8L (90-00)</td></tr> </table>	Dientes	139	Contrapeso	No	Diám Ext.	11.75"	OEM	4736016	V6 2.5L, 3.3L, 3.8L (90-00)		 <p>AA-C401</p>	<table border="1"> <tr><td>Dientes</td><td>139</td></tr> <tr><td>Contrapeso</td><td>No</td></tr> <tr><td>Diám Ext.</td><td>11.75"</td></tr> <tr><td>OEM</td><td>4348286</td></tr> <tr><td colspan="2">L4 135 (2.2L), Serie K (81-85)</td></tr> </table>	Dientes	139	Contrapeso	No	Diám Ext.	11.75"	OEM	4348286	L4 135 (2.2L), Serie K (81-85)	
Dientes	139																						
Contrapeso	No																						
Diám Ext.	11.75"																						
OEM	4736016																						
V6 2.5L, 3.3L, 3.8L (90-00)																							
Dientes	139																						
Contrapeso	No																						
Diám Ext.	11.75"																						
OEM	4348286																						
L4 135 (2.2L), Serie K (81-85)																							
 <p>AA-C402</p>	<table border="1"> <tr><td>Dientes</td><td>139</td></tr> <tr><td>Contrapeso</td><td>No</td></tr> <tr><td>Diám Ext.</td><td>11.75"</td></tr> <tr><td>OEM</td><td>4348287</td></tr> <tr><td colspan="2">L4 156 (2.6L), Serie K (81-85) (motor Mitsubishi)</td></tr> </table>	Dientes	139	Contrapeso	No	Diám Ext.	11.75"	OEM	4348287	L4 156 (2.6L), Serie K (81-85) (motor Mitsubishi)		 <p>AA-C403</p>	<table border="1"> <tr><td>Dientes</td><td>N / A</td></tr> <tr><td>Contrapeso</td><td>N / A</td></tr> <tr><td>Diám Ext.</td><td>12.125"</td></tr> <tr><td>OEM</td><td>2204768</td></tr> <tr><td colspan="2">V8 318, 340, 360, 383, 426, 440 (62-77) (trans. A727 / TF8) (Agujeros del centro no simétricos)</td></tr> </table>	Dientes	N / A	Contrapeso	N / A	Diám Ext.	12.125"	OEM	2204768	V8 318, 340, 360, 383, 426, 440 (62-77) (trans. A727 / TF8) (Agujeros del centro no simétricos)	
Dientes	139																						
Contrapeso	No																						
Diám Ext.	11.75"																						
OEM	4348287																						
L4 156 (2.6L), Serie K (81-85) (motor Mitsubishi)																							
Dientes	N / A																						
Contrapeso	N / A																						
Diám Ext.	12.125"																						
OEM	2204768																						
V8 318, 340, 360, 383, 426, 440 (62-77) (trans. A727 / TF8) (Agujeros del centro no simétricos)																							
 <p>AA-C404</p>	<table border="1"> <tr><td>Dientes</td><td>N / A</td></tr> <tr><td>Contrapeso</td><td>N / A</td></tr> <tr><td>Diám Ext.</td><td>10.75"</td></tr> <tr><td>OEM</td><td>4058429</td></tr> <tr><td colspan="2">L6 225, V8 318, 340, 360, 383, 426, 440 (62-89) (trans. A904 / TF6) (Agujeros del centro no simétricos)</td></tr> </table>	Dientes	N / A	Contrapeso	N / A	Diám Ext.	10.75"	OEM	4058429	L6 225, V8 318, 340, 360, 383, 426, 440 (62-89) (trans. A904 / TF6) (Agujeros del centro no simétricos)		 <p>AA-C405</p>	<table border="1"> <tr><td>Dientes</td><td>N / A</td></tr> <tr><td>Contrapeso</td><td>N / A</td></tr> <tr><td>Diám Ext.</td><td>12.125"</td></tr> <tr><td>OEM</td><td>2204719</td></tr> <tr><td colspan="2">L6 198, 225, (62-77) (trans. A904 / TF6) (Agujeros del centro simétricos)</td></tr> </table>	Dientes	N / A	Contrapeso	N / A	Diám Ext.	12.125"	OEM	2204719	L6 198, 225, (62-77) (trans. A904 / TF6) (Agujeros del centro simétricos)	
Dientes	N / A																						
Contrapeso	N / A																						
Diám Ext.	10.75"																						
OEM	4058429																						
L6 225, V8 318, 340, 360, 383, 426, 440 (62-89) (trans. A904 / TF6) (Agujeros del centro no simétricos)																							
Dientes	N / A																						
Contrapeso	N / A																						
Diám Ext.	12.125"																						
OEM	2204719																						
L6 198, 225, (62-77) (trans. A904 / TF6) (Agujeros del centro simétricos)																							
 <p>AA-C406</p>	<table border="1"> <tr><td>Dientes</td><td>N / A</td></tr> <tr><td>Contrapeso</td><td>N / A</td></tr> <tr><td>Diám Ext.</td><td>10.75"</td></tr> <tr><td>OEM</td><td>4058428</td></tr> <tr><td colspan="2">L6 198, 225, (62-87) (trans. A904 / TF6) (Agujeros del centro simétricos)</td></tr> </table>	Dientes	N / A	Contrapeso	N / A	Diám Ext.	10.75"	OEM	4058428	L6 198, 225, (62-87) (trans. A904 / TF6) (Agujeros del centro simétricos)		 <p>AA-C407</p>	<table border="1"> <tr><td>Dientes</td><td>106</td></tr> <tr><td>Contrapeso</td><td>No</td></tr> <tr><td>Diám Ext.</td><td>10.68"</td></tr> <tr><td>OEM</td><td>4567143</td></tr> <tr><td colspan="2">L4 2.0L, 2.4L Neon, Stratus, Sebring (95-06)</td></tr> </table>	Dientes	106	Contrapeso	No	Diám Ext.	10.68"	OEM	4567143	L4 2.0L, 2.4L Neon, Stratus, Sebring (95-06)	
Dientes	N / A																						
Contrapeso	N / A																						
Diám Ext.	10.75"																						
OEM	4058428																						
L6 198, 225, (62-87) (trans. A904 / TF6) (Agujeros del centro simétricos)																							
Dientes	106																						
Contrapeso	No																						
Diám Ext.	10.68"																						
OEM	4567143																						
L4 2.0L, 2.4L Neon, Stratus, Sebring (95-06)																							
 <p>AA-C408</p>	<table border="1"> <tr><td>Dientes</td><td>139</td></tr> <tr><td>Contrapeso</td><td>No</td></tr> <tr><td>Diám Ext.</td><td>11.75"</td></tr> <tr><td>OEM</td><td>4348322</td></tr> <tr><td colspan="2">L4 2.2L, 2.5L, 2.6L, V6 3.0L Shadow, Spirit, Caravan (86-92)</td></tr> </table>	Dientes	139	Contrapeso	No	Diám Ext.	11.75"	OEM	4348322	L4 2.2L, 2.5L, 2.6L, V6 3.0L Shadow, Spirit, Caravan (86-92)		 <p>AA-C409</p>	<table border="1"> <tr><td>Dientes</td><td>139</td></tr> <tr><td>Contrapeso</td><td>No</td></tr> <tr><td>Diám Ext.</td><td>11.75"</td></tr> <tr><td>OEM</td><td>4377411</td></tr> <tr><td colspan="2">L4 156 (2.6L) Mini Van, Ram 50, Raider (86-87) (motor Mitsubishi)</td></tr> </table>	Dientes	139	Contrapeso	No	Diám Ext.	11.75"	OEM	4377411	L4 156 (2.6L) Mini Van, Ram 50, Raider (86-87) (motor Mitsubishi)	
Dientes	139																						
Contrapeso	No																						
Diám Ext.	11.75"																						
OEM	4348322																						
L4 2.2L, 2.5L, 2.6L, V6 3.0L Shadow, Spirit, Caravan (86-92)																							
Dientes	139																						
Contrapeso	No																						
Diám Ext.	11.75"																						
OEM	4377411																						
L4 156 (2.6L) Mini Van, Ram 50, Raider (86-87) (motor Mitsubishi)																							

1.1 Aros dentados transmisión automática

Automatic transmission flex plates

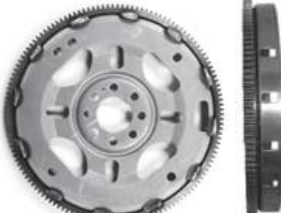

Chrysler / Dodge

<p>AA-C410</p> 	<table border="1"> <tr><td>Dientes</td><td>139</td></tr> <tr><td>Contrapeso</td><td>No</td></tr> <tr><td>Diám Ext.</td><td>11.75"</td></tr> <tr><td>OEM</td><td>4736190</td></tr> <tr><td colspan="2">V6 3.0L, 3.3L, 3.8L Caravan, Voyager (98-04), Intrepid V6 3.5L (1997) (turbina 90°)</td></tr> </table>	Dientes	139	Contrapeso	No	Diám Ext.	11.75"	OEM	4736190	V6 3.0L, 3.3L, 3.8L Caravan, Voyager (98-04), Intrepid V6 3.5L (1997) (turbina 90°)		<p>AA-C411</p> 	<table border="1"> <tr><td>Dientes</td><td>139</td></tr> <tr><td>Contrapeso</td><td>No</td></tr> <tr><td>Diám Ext.</td><td>11.75"</td></tr> <tr><td>OEM</td><td>N / D</td></tr> <tr><td colspan="2">L4 2.2L, 2.5L, 2.6L, V6 3.0L Shadow, Spirit, Caravan (86-92) (conv. 3 y 4 puntos de apoyo)</td></tr> </table>	Dientes	139	Contrapeso	No	Diám Ext.	11.75"	OEM	N / D	L4 2.2L, 2.5L, 2.6L, V6 3.0L Shadow, Spirit, Caravan (86-92) (conv. 3 y 4 puntos de apoyo)	
Dientes	139																						
Contrapeso	No																						
Diám Ext.	11.75"																						
OEM	4736190																						
V6 3.0L, 3.3L, 3.8L Caravan, Voyager (98-04), Intrepid V6 3.5L (1997) (turbina 90°)																							
Dientes	139																						
Contrapeso	No																						
Diám Ext.	11.75"																						
OEM	N / D																						
L4 2.2L, 2.5L, 2.6L, V6 3.0L Shadow, Spirit, Caravan (86-92) (conv. 3 y 4 puntos de apoyo)																							
<p>AA-C412</p> 	<table border="1"> <tr><td>Dientes</td><td>139</td></tr> <tr><td>Contrapeso</td><td>No</td></tr> <tr><td>Diám Ext.</td><td>11.75"</td></tr> <tr><td>OEM</td><td>4376479</td></tr> <tr><td colspan="2">L4 135 (2.2L), Serie K (78-85) (conv. 6 tornillos de cigüeñal y 4 puntos de apoyo)</td></tr> </table>	Dientes	139	Contrapeso	No	Diám Ext.	11.75"	OEM	4376479	L4 135 (2.2L), Serie K (78-85) (conv. 6 tornillos de cigüeñal y 4 puntos de apoyo)		<p>AA-C413</p> 	<table border="1"> <tr><td>Dientes</td><td>N / A</td></tr> <tr><td>Contrapeso</td><td>No</td></tr> <tr><td>Diám Ext.</td><td>11.56"</td></tr> <tr><td>OEM</td><td>53008665</td></tr> <tr><td colspan="2">V6 3.9L Pick ups Ram 1500, Ram Van 1500 (94-00)</td></tr> </table>	Dientes	N / A	Contrapeso	No	Diám Ext.	11.56"	OEM	53008665	V6 3.9L Pick ups Ram 1500, Ram Van 1500 (94-00)	
Dientes	139																						
Contrapeso	No																						
Diám Ext.	11.75"																						
OEM	4376479																						
L4 135 (2.2L), Serie K (78-85) (conv. 6 tornillos de cigüeñal y 4 puntos de apoyo)																							
Dientes	N / A																						
Contrapeso	No																						
Diám Ext.	11.56"																						
OEM	53008665																						
V6 3.9L Pick ups Ram 1500, Ram Van 1500 (94-00)																							
<p>AA-C414</p> 	<table border="1"> <tr><td>Dientes</td><td>N / A</td></tr> <tr><td>Contrapeso</td><td>No</td></tr> <tr><td>Diám Ext.</td><td>11.56"</td></tr> <tr><td>OEM</td><td>53008669</td></tr> <tr><td colspan="2">V8 5.2L, 5.9L Pick ups Ram 1500, 2500, 3500 (94-96)</td></tr> </table>	Dientes	N / A	Contrapeso	No	Diám Ext.	11.56"	OEM	53008669	V8 5.2L, 5.9L Pick ups Ram 1500, 2500, 3500 (94-96)		<p>AA-C415</p> 	<table border="1"> <tr><td>Dientes</td><td>N / A</td></tr> <tr><td>Contrapeso</td><td>Si</td></tr> <tr><td>Diám Ext.</td><td>11.56"</td></tr> <tr><td>OEM</td><td>4863841</td></tr> <tr><td colspan="2">V8 5.2L, 5.9L Pick ups Ram 1500, 2500, 3500 (97-04)</td></tr> </table>	Dientes	N / A	Contrapeso	Si	Diám Ext.	11.56"	OEM	4863841	V8 5.2L, 5.9L Pick ups Ram 1500, 2500, 3500 (97-04)	
Dientes	N / A																						
Contrapeso	No																						
Diám Ext.	11.56"																						
OEM	53008669																						
V8 5.2L, 5.9L Pick ups Ram 1500, 2500, 3500 (94-96)																							
Dientes	N / A																						
Contrapeso	Si																						
Diám Ext.	11.56"																						
OEM	4863841																						
V8 5.2L, 5.9L Pick ups Ram 1500, 2500, 3500 (97-04)																							
<p>AA-C416</p>  <p>5 agujeros</p>	<table border="1"> <tr><td>Dientes</td><td>N / A</td></tr> <tr><td>Contrapeso</td><td>N / A</td></tr> <tr><td>Diám Ext.</td><td>8.875"</td></tr> <tr><td>OEM</td><td>23211-21054</td></tr> <tr><td colspan="2">L4 1.5L, 1.6L Dodge Verna (Hyundai Accent) (03-06)</td></tr> </table>	Dientes	N / A	Contrapeso	N / A	Diám Ext.	8.875"	OEM	23211-21054	L4 1.5L, 1.6L Dodge Verna (Hyundai Accent) (03-06)		<p>AA-C417</p> 	<table border="1"> <tr><td>Dientes</td><td>139</td></tr> <tr><td>Contrapeso</td><td>No</td></tr> <tr><td>Diám Ext.</td><td>11.75"</td></tr> <tr><td>OEM</td><td>4736299AB</td></tr> <tr><td colspan="2">V6 2.7L, 3.5L Intrepid (00-04), V6 2.7L Stratus (05-06), V6 3.3L, 3.8L, 4.0L Caravan, Grand Caravan (04-11) V6 2.7L, 3.5L Charger (06-07), V6 3.8L Jeep Wrangler (07-11)</td></tr> </table>	Dientes	139	Contrapeso	No	Diám Ext.	11.75"	OEM	4736299AB	V6 2.7L, 3.5L Intrepid (00-04), V6 2.7L Stratus (05-06), V6 3.3L, 3.8L, 4.0L Caravan, Grand Caravan (04-11) V6 2.7L, 3.5L Charger (06-07), V6 3.8L Jeep Wrangler (07-11)	
Dientes	N / A																						
Contrapeso	N / A																						
Diám Ext.	8.875"																						
OEM	23211-21054																						
L4 1.5L, 1.6L Dodge Verna (Hyundai Accent) (03-06)																							
Dientes	139																						
Contrapeso	No																						
Diám Ext.	11.75"																						
OEM	4736299AB																						
V6 2.7L, 3.5L Intrepid (00-04), V6 2.7L Stratus (05-06), V6 3.3L, 3.8L, 4.0L Caravan, Grand Caravan (04-11) V6 2.7L, 3.5L Charger (06-07), V6 3.8L Jeep Wrangler (07-11)																							
<p>AA-C418</p> 	<table border="1"> <tr><td>Dientes</td><td>N / A</td></tr> <tr><td>Contrapeso</td><td>No</td></tr> <tr><td>Diám Ext.</td><td>11.56"</td></tr> <tr><td>OEM</td><td>52118255</td></tr> <tr><td colspan="2">V8 5.2L, 5.9L Pick ups Ram 1500, 2500, 3500 (96-03)</td></tr> </table>	Dientes	N / A	Contrapeso	No	Diám Ext.	11.56"	OEM	52118255	V8 5.2L, 5.9L Pick ups Ram 1500, 2500, 3500 (96-03)		<p>AA-C419</p> 	<table border="1"> <tr><td>Dientes</td><td>N / A</td></tr> <tr><td>Contrapeso</td><td>No</td></tr> <tr><td>Diám Ext.</td><td>11.56"</td></tr> <tr><td>OEM</td><td>52118256</td></tr> <tr><td colspan="2">V6 3.9L Pick ups Ram 1500, Dakota (96-03)</td></tr> </table>	Dientes	N / A	Contrapeso	No	Diám Ext.	11.56"	OEM	52118256	V6 3.9L Pick ups Ram 1500, Dakota (96-03)	
Dientes	N / A																						
Contrapeso	No																						
Diám Ext.	11.56"																						
OEM	52118255																						
V8 5.2L, 5.9L Pick ups Ram 1500, 2500, 3500 (96-03)																							
Dientes	N / A																						
Contrapeso	No																						
Diám Ext.	11.56"																						
OEM	52118256																						
V6 3.9L Pick ups Ram 1500, Dakota (96-03)																							

1.1 Aros dentados transmisión automática

Automatic transmission flex plates





Chrysler / Dodge

	AA-C420	Dientes	131
		Contrapeso	No
		Diám Ext.	13.20"
		OEM	04736604AA
	Jeep Liberty V6 3.7L (02-07) Dodge Dakota (00-11), Durango (99-09), Ram 1500, 2500 (02-12), Jeep Grand Cherokee (99-13) V6 3.7L, V8 4.7L, 5.7L HEMI		

	AA-C421	Dientes	139
		Contrapeso	No
		Diám Ext.	11.75"
		OEM	4736179AB
	Chrysler Concorde V6 2.7L, 3.2L (00-01) Sebring V6 2.7L (01-04), Dodge Intrepid V6 2.7L, 3.2L (97-01), 3.5L (00-01) Stratus V6 2.7L (01-04)		

	AA-C422	Dientes	131
		Contrapeso	No
		Diám Ext.	13.20"
		OEM	04752574AB
	Chrysler 300 V8 5.7L (05-16) Ram 1500, 2500 V8 5.7L (13-16) Charger V8 5.7L (06-16)		

	AA-C423	Dientes	152
		Contrapeso	No
		Diám Ext.	15.31"
		OEM	5015709AB,
	Dodge D250, D350 (89-93), Pick up Ram 2500, 3500 (94-09) con motor diesel Cummins L6 5.9L		

	AA-C424	Dientes	131
		Contrapeso	No
		Diám Ext.	13.20"
		OEM	47367844AA
	Dodge Ram 1500, 2500, 3500 V8 5.7L (12-20), Durango V8 5.7L (12-16), Jeep Grand Cherokee V8 5.7L (12-14)		

	AA-C426	Dientes	131
		Contrapeso	No
		Diám Ext.	13.20"
		OEM	04752455AA
	Dodge Charger SRT8 V8 6.1L (06-10), 300 SRT8 V8 6.1L (07-10), Jeep Grand Cherokee SRT8 V8 6.1L (07-10)		

Cummins

	AA-M500	Dientes	146
		Contrapeso	No
		Diám Ext.	14.815"
		OEM	3918957
	L4 239 (3.9L) (Cummins diesel) 4B, 4BT, 4BTA		

	AA-M501	Dientes	159
		Contrapeso	No
		Diám Ext.	16.05"
		OEM	3918959
	Cummins engine B Series 3.9L, 5.9L, 6.7L (Allison transmission)		

1.1 Aros dentados transmisión automática

Automatic transmission flex plates





Ford

AA-F200 	Dientes	164
	Contrapeso	Si
	Diám Ext.	14.23"
	OEM	EOAZ-6375A
	V8 289, 302, 351W (65-85) (transmision C4 o FMX)	

AA-F201 	Dientes	164
	Contrapeso	Si
	Diám Ext.	14.23"
	OEM	D1AZ-6375A
	V8 351M, 400 (71-82) (transmisión C6)	

AA-F202 	Dientes	164
	Contrapeso	No
	Diám Ext.	14.23"
	OEM	C5TZ-6375-T
	L6 240, 250, 300 (65-81) (transmisión C4 o FMX)	

AA-F203 	Dientes	135
	Contrapeso	No
	Diám Ext.	11.30"
	OEM	D4ZZ-6375D
	L4 140 Fairmont, Mustang y Pinto (74-80) (transmisión C3)	

AA-F204 	Dientes	135
	Contrapeso	No
	Diám Ext.	11.30"
	OEM	D5FZ-6375-A
	L4 140 Fairmont, Mustang y Pinto (74-80) (transmisión C4)	

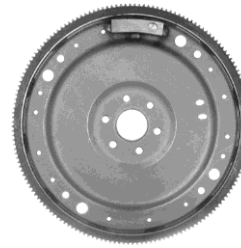
AA-F205 	Dientes	164
	Contrapeso	Si
	Diám Ext.	14.23"
	OEM	D1ZZ-6375A
	V8 302, 351 autos y pick ups F-100, F-150 (71-94) (transmisión C6)	

AA-F206 	Dientes	164
	Contrapeso	Si
	Diám Ext.	14.23"
	OEM	E0SZ-6375-A
	V8 255, 302 Mustang, Thunderbird, Cougar (80-82) (transmisión AOD)	

AA-F207 	Dientes	164
	Contrapeso	No
	Diám Ext.	14.23"
	OEM	D5TZ-6375A
	L6 300 (4.9L) Pick ups F-100, F-150 (75-94) (transmisión C6)	

AA-F208 	Dientes	184
	Contrapeso	No
	Diám Ext.	15.55"
	OEM	C5AZ-6375-D
	V8 352, 360, 390, 427 autos y pick ups (65-76)	











AA-F209 	Dientes	164
	Contrapeso	Si
	Diám Ext.	14.23"
	OEM	E2AZ-6375A
	V8 302 (5.0L) F-100, F-150, Mustang, Thunderbird, Cougar (83-95) (transmisión AOD, AODE)	

1.1 Aros dentados transmisión automática

Automatic transmission flex plates



Ford

<p>AA-F210</p> 	<table border="1"> <tr><td>Dientes</td><td>135</td></tr> <tr><td>Contrapeso</td><td>No</td></tr> <tr><td>Diám Ext.</td><td>11.30"</td></tr> <tr><td>OEM</td><td>D1FZ-6375-A</td></tr> <tr><td colspan="2">L4 122, 140 Pinto (71-74)</td></tr> </table>	Dientes	135	Contrapeso	No	Diám Ext.	11.30"	OEM	D1FZ-6375-A	L4 122, 140 Pinto (71-74)		<p>AA-F211</p> 	<table border="1"> <tr><td>Dientes</td><td>157</td></tr> <tr><td>Contrapeso</td><td>Si</td></tr> <tr><td>Diám Ext.</td><td>13.30"</td></tr> <tr><td>OEM</td><td>C3AZ-6375L</td></tr> <tr><td colspan="2">V8 289, 302 Falcon, Maverick y Mustang (64-77) (transmisión C4 o FMX) Turbina C4 mediana</td></tr> </table>	Dientes	157	Contrapeso	Si	Diám Ext.	13.30"	OEM	C3AZ-6375L	V8 289, 302 Falcon, Maverick y Mustang (64-77) (transmisión C4 o FMX) Turbina C4 mediana	
Dientes	135																						
Contrapeso	No																						
Diám Ext.	11.30"																						
OEM	D1FZ-6375-A																						
L4 122, 140 Pinto (71-74)																							
Dientes	157																						
Contrapeso	Si																						
Diám Ext.	13.30"																						
OEM	C3AZ-6375L																						
V8 289, 302 Falcon, Maverick y Mustang (64-77) (transmisión C4 o FMX) Turbina C4 mediana																							
<p>AA-F212</p> 	<table border="1"> <tr><td>Dientes</td><td>157</td></tr> <tr><td>Contrapeso</td><td>No</td></tr> <tr><td>Diám Ext.</td><td>13.30"</td></tr> <tr><td>OEM</td><td>C9OZ-6375-A</td></tr> <tr><td colspan="2">L6 250 Falcon, Granada, Maverick, Mustang (69-80)</td></tr> </table>	Dientes	157	Contrapeso	No	Diám Ext.	13.30"	OEM	C9OZ-6375-A	L6 250 Falcon, Granada, Maverick, Mustang (69-80)		<p>AA-F213</p> 	<table border="1"> <tr><td>Dientes</td><td>164</td></tr> <tr><td>Contrapeso</td><td>No</td></tr> <tr><td>Diám Ext.</td><td>14.23"</td></tr> <tr><td>OEM</td><td>D1SZ-6375A</td></tr> <tr><td colspan="2">V8 429, 460 autos y pick ups (68-78)</td></tr> </table>	Dientes	164	Contrapeso	No	Diám Ext.	14.23"	OEM	D1SZ-6375A	V8 429, 460 autos y pick ups (68-78)	
Dientes	157																						
Contrapeso	No																						
Diám Ext.	13.30"																						
OEM	C9OZ-6375-A																						
L6 250 Falcon, Granada, Maverick, Mustang (69-80)																							
Dientes	164																						
Contrapeso	No																						
Diám Ext.	14.23"																						
OEM	D1SZ-6375A																						
V8 429, 460 autos y pick ups (68-78)																							
<p>AA-F214</p> 	<table border="1"> <tr><td>Dientes</td><td>N / A</td></tr> <tr><td>Contrapeso</td><td>N / A</td></tr> <tr><td>Diám Ext.</td><td>9.875"</td></tr> <tr><td>OEM</td><td>C3DZ-6375-B</td></tr> <tr><td colspan="2">L6 170, 200 (64-82) (transmisión C4)</td></tr> </table>	Dientes	N / A	Contrapeso	N / A	Diám Ext.	9.875"	OEM	C3DZ-6375-B	L6 170, 200 (64-82) (transmisión C4)		<p>AA-F215</p> 	<table border="1"> <tr><td>Dientes</td><td>164</td></tr> <tr><td>Contrapeso</td><td>Si</td></tr> <tr><td>Diám Ext.</td><td>14.23"</td></tr> <tr><td>OEM</td><td>D9TZ-6375-A</td></tr> <tr><td colspan="2">V8 460 (7.5L) pick ups (79-96) (con contrapeso)</td></tr> </table>	Dientes	164	Contrapeso	Si	Diám Ext.	14.23"	OEM	D9TZ-6375-A	V8 460 (7.5L) pick ups (79-96) (con contrapeso)	
Dientes	N / A																						
Contrapeso	N / A																						
Diám Ext.	9.875"																						
OEM	C3DZ-6375-B																						
L6 170, 200 (64-82) (transmisión C4)																							
Dientes	164																						
Contrapeso	Si																						
Diám Ext.	14.23"																						
OEM	D9TZ-6375-A																						
V8 460 (7.5L) pick ups (79-96) (con contrapeso)																							
<p>AA-F216</p> 	<table border="1"> <tr><td>Dientes</td><td>164</td></tr> <tr><td>Contrapeso</td><td>Si</td></tr> <tr><td>Diám Ext.</td><td>14.23"</td></tr> <tr><td>OEM</td><td>E3DZ-6375-B</td></tr> <tr><td colspan="2">V6 232 LTD, Mustang (83-86) (transmisión C5)</td></tr> </table>	Dientes	164	Contrapeso	Si	Diám Ext.	14.23"	OEM	E3DZ-6375-B	V6 232 LTD, Mustang (83-86) (transmisión C5)		<p>AA-F217</p> 	<table border="1"> <tr><td>Dientes</td><td>164</td></tr> <tr><td>Contrapeso</td><td>Si</td></tr> <tr><td>Diám Ext.</td><td>14.23"</td></tr> <tr><td>OEM</td><td>E3SZ-6375B</td></tr> <tr><td colspan="2">V6 232 Cougar, Thunderbird (83-87) (transmisión C5)</td></tr> </table>	Dientes	164	Contrapeso	Si	Diám Ext.	14.23"	OEM	E3SZ-6375B	V6 232 Cougar, Thunderbird (83-87) (transmisión C5)	
Dientes	164																						
Contrapeso	Si																						
Diám Ext.	14.23"																						
OEM	E3DZ-6375-B																						
V6 232 LTD, Mustang (83-86) (transmisión C5)																							
Dientes	164																						
Contrapeso	Si																						
Diám Ext.	14.23"																						
OEM	E3SZ-6375B																						
V6 232 Cougar, Thunderbird (83-87) (transmisión C5)																							
<p>AA-F218</p> 	<table border="1"> <tr><td>Dientes</td><td>164</td></tr> <tr><td>Contrapeso</td><td>Si</td></tr> <tr><td>Diám Ext.</td><td>14.23"</td></tr> <tr><td>OEM</td><td>E9SZ-6375B</td></tr> <tr><td colspan="2">V6 3.8L (232) Mustang, Thunderbird, Cougar (88-95)</td></tr> </table>	Dientes	164	Contrapeso	Si	Diám Ext.	14.23"	OEM	E9SZ-6375B	V6 3.8L (232) Mustang, Thunderbird, Cougar (88-95)		<p>AA-F219</p> 	<table border="1"> <tr><td>Dientes</td><td>138</td></tr> <tr><td>Contrapeso</td><td>No</td></tr> <tr><td>Diám Ext.</td><td>11.69"</td></tr> <tr><td>OEM</td><td>E7RY-6375B</td></tr> <tr><td colspan="2">V6 177 (88-89) (transmisión A4LD)</td></tr> </table>	Dientes	138	Contrapeso	No	Diám Ext.	11.69"	OEM	E7RY-6375B	V6 177 (88-89) (transmisión A4LD)	
Dientes	164																						
Contrapeso	Si																						
Diám Ext.	14.23"																						
OEM	E9SZ-6375B																						
V6 3.8L (232) Mustang, Thunderbird, Cougar (88-95)																							
Dientes	138																						
Contrapeso	No																						
Diám Ext.	11.69"																						
OEM	E7RY-6375B																						
V6 177 (88-89) (transmisión A4LD)																							

1.1 Aros dentados transmisión automática

Automatic transmission flex plates





Ford

AA-F220 	Dientes	164
	Contrapeso	Si
	Diám Ext.	14.23"
	OEM	E1TZ-6375C
	V8 302 (5.0L) pick ups F-100, F-150 (81-96) (transmisión C6 / E4OD)	

AA-F221 	Dientes	135
	Contrapeso	No
	Diám Ext.	11.30"
	OEM	E83Z-6375A
	L4 140 (2.3L), 153 (2.5L) Tempo, Taurus, Topaz; (84-94)	

AA-F222 	Dientes	135
	Contrapeso	No
	Diám Ext.	11.30"
	OEM	E6DZ-6375
	V6 183 (3.0L) Taurus, Topaz (86-90)	

AA-F223 	Dientes	164
	Contrapeso	No
	Diám Ext.	14.23"
	OEM	F1AZ-6375-A
	V8 4.6L (281) Thunderbird, Cougar, Grand Marquis, Lincoln Town Car (92-95)	

AA-F224 	Dientes	164
	Contrapeso	No
	Diám Ext.	14.23"
	OEM	E3TZ-6375-G
	L6 300 (4.9L) Pick ups F-100, F-150 (83-90) (transmisión C5 / AOD)	

AA-F225 	Dientes	164
	Contrapeso	Si
	Diám Ext.	14.23"
	OEM	E5SZ-6375-A
	V6 232 (3.8L) Thunderbird, Cougar (85-87) (transmisión AOD)	

AA-F226 	Dientes	184
	Contrapeso	Si
	Diám Ext.	15.55"
	OEM	C6AZ-6375-B
	V8 427, 428 autos (66-70) (transmisión C6)	

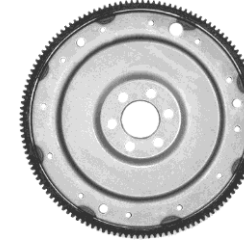
AA-F227 	Dientes	132
	Contrapeso	No
	Diám Ext.	11.187"
	OEM	D8BZ-6375-B
	L6 200 Fairmont, Mustang, Thunderbird (78-81) (transmisión C3)	

AA-F228 	Dientes	164
	Contrapeso	Si
	Diám Ext.	14.23"
	OEM	E2SZ-6375-A
	V6 232 Ford LTD (83-86) (transmisión AOD)	

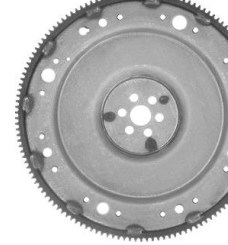







AA-F230 	Dientes	138
	Contrapeso	No
	Diám Ext.	11.69"
	OEM	D4ZZ-6375C
	V6 171 Mustang, Ranger, Bronco II (79-85) (transmisión C4)	

1.1 Aros dentados transmisión automática

Automatic transmission flex plates

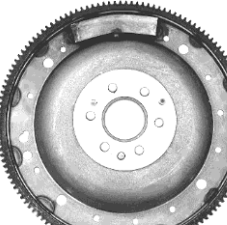
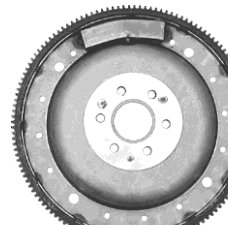

Ford

<p>AA-F231</p> 	<table border="1"> <tr><td>Dientes</td><td>141</td></tr> <tr><td>Contrapeso</td><td>Si</td></tr> <tr><td>Diám Ext.</td><td>11.94"</td></tr> <tr><td>OEM</td><td>D5ZZ-6375-A</td></tr> </table> <p>V8 302 Mustang II, Mustang (75-79)</p>	Dientes	141	Contrapeso	Si	Diám Ext.	11.94"	OEM	D5ZZ-6375-A	<p>AA-F232</p> 	<table border="1"> <tr><td>Dientes</td><td>164</td></tr> <tr><td>Contrapeso</td><td>Si</td></tr> <tr><td>Diám Ext.</td><td>14.23"</td></tr> <tr><td>OEM</td><td>D1ZZ-6375-C</td></tr> </table> <p>V8 351C (Cleveland) Mustang, Cougar, Torino (71-74)</p>	Dientes	164	Contrapeso	Si	Diám Ext.	14.23"	OEM	D1ZZ-6375-C
Dientes	141																		
Contrapeso	Si																		
Diám Ext.	11.94"																		
OEM	D5ZZ-6375-A																		
Dientes	164																		
Contrapeso	Si																		
Diám Ext.	14.23"																		
OEM	D1ZZ-6375-C																		
<p>AA-F233</p> 	<table border="1"> <tr><td>Dientes</td><td>135</td></tr> <tr><td>Contrapeso</td><td>No</td></tr> <tr><td>Diám Ext.</td><td>11.30"</td></tr> <tr><td>OEM</td><td>E5TZ-6375-D</td></tr> </table> <p>L4 2.3L (140), 2.5L (153) Ranger (85-01), Mazda B2300, B2500 (94-00)</p>	Dientes	135	Contrapeso	No	Diám Ext.	11.30"	OEM	E5TZ-6375-D	<p>AA-F234</p> 	<table border="1"> <tr><td>Dientes</td><td>138</td></tr> <tr><td>Contrapeso</td><td>No</td></tr> <tr><td>Diám Ext.</td><td>11.69"</td></tr> <tr><td>OEM</td><td>D5ZZ-6375-B</td></tr> </table> <p>V6 171 Mustang II, Mustang (75-79) (transmisión C3)</p>	Dientes	138	Contrapeso	No	Diám Ext.	11.69"	OEM	D5ZZ-6375-B
Dientes	135																		
Contrapeso	No																		
Diám Ext.	11.30"																		
OEM	E5TZ-6375-D																		
Dientes	138																		
Contrapeso	No																		
Diám Ext.	11.69"																		
OEM	D5ZZ-6375-B																		
<p>AA-F235</p> 	<table border="1"> <tr><td>Dientes</td><td>138</td></tr> <tr><td>Contrapeso</td><td>No</td></tr> <tr><td>Diám Ext.</td><td>11.69"</td></tr> <tr><td>OEM</td><td>F1TZ-6375-A</td></tr> </table> <p>V6 177 (2.9L), 244 (4.0L) Ranger, Explorer (86-96), Mazda B4000, Navajo (91-97)</p>	Dientes	138	Contrapeso	No	Diám Ext.	11.69"	OEM	F1TZ-6375-A	<p>AA-F237</p> 	<table border="1"> <tr><td>Dientes</td><td>135</td></tr> <tr><td>Contrapeso</td><td>No</td></tr> <tr><td>Diám Ext.</td><td>11.30"</td></tr> <tr><td>OEM</td><td>E63Z-6375-A</td></tr> </table> <p>L4 153 (2.5L), Taurus, Sable (86-87)</p>	Dientes	135	Contrapeso	No	Diám Ext.	11.30"	OEM	E63Z-6375-A
Dientes	138																		
Contrapeso	No																		
Diám Ext.	11.69"																		
OEM	F1TZ-6375-A																		
Dientes	135																		
Contrapeso	No																		
Diám Ext.	11.30"																		
OEM	E63Z-6375-A																		
<p>AA-F238</p> 	<table border="1"> <tr><td>Dientes</td><td>135</td></tr> <tr><td>Contrapeso</td><td>No</td></tr> <tr><td>Diám Ext.</td><td>11.30"</td></tr> <tr><td>OEM</td><td>E69Z-6375-A</td></tr> </table> <p>V6 3.0L (183) Ranger (91-08), Mazda B3000 (94-98)</p>	Dientes	135	Contrapeso	No	Diám Ext.	11.30"	OEM	E69Z-6375-A	<p>AA-F239</p> 	<table border="1"> <tr><td>Dientes</td><td>135</td></tr> <tr><td>Contrapeso</td><td>Si</td></tr> <tr><td>Diám Ext.</td><td>11.30"</td></tr> <tr><td>OEM</td><td>E8DZ-6375-A</td></tr> </table> <p>V6 232 (3.8L) Taurus, Sable (88-89)</p>	Dientes	135	Contrapeso	Si	Diám Ext.	11.30"	OEM	E8DZ-6375-A
Dientes	135																		
Contrapeso	No																		
Diám Ext.	11.30"																		
OEM	E69Z-6375-A																		
Dientes	135																		
Contrapeso	Si																		
Diám Ext.	11.30"																		
OEM	E8DZ-6375-A																		
<p>AA-F240</p> 	<table border="1"> <tr><td>Dientes</td><td>135</td></tr> <tr><td>Contrapeso</td><td>Si</td></tr> <tr><td>Diám Ext.</td><td>11.30"</td></tr> <tr><td>OEM</td><td>E9DZ-6375-B</td></tr> </table> <p>V6 232 (3.8L) Taurus, Sable (89-90)</p>	Dientes	135	Contrapeso	Si	Diám Ext.	11.30"	OEM	E9DZ-6375-B	<p>AA-F241</p> 	<table border="1"> <tr><td>Dientes</td><td>135</td></tr> <tr><td>Contrapeso</td><td>Si</td></tr> <tr><td>Diám Ext.</td><td>11.30"</td></tr> <tr><td>OEM</td><td>F1DZ-6375-C</td></tr> </table> <p>V6 3.8L Taurus, Sable, Windstar (91-00)</p>	Dientes	135	Contrapeso	Si	Diám Ext.	11.30"	OEM	F1DZ-6375-C
Dientes	135																		
Contrapeso	Si																		
Diám Ext.	11.30"																		
OEM	E9DZ-6375-B																		
Dientes	135																		
Contrapeso	Si																		
Diám Ext.	11.30"																		
OEM	F1DZ-6375-C																		

1.1 Aros dentados transmisión automática

Automatic transmission flex plates





Ford

AA-F242 	Dientes	135
	Contrapeso	No
	Diám Ext.	11.30"
	OEM	F1DZ-6375-A
	V6 3.0L Taurus, Sable (91-95)	

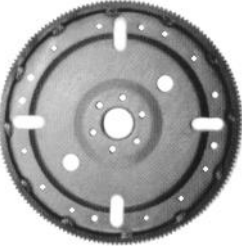
AA-F243 	Dientes	135
	Contrapeso	No
	Diám Ext.	11.30"
	OEM	F3DZ-6375-A
	V6 3.2L Taurus (93-95)	

AA-F244 	Dientes	164
	Contrapeso	No
	Diám Ext.	14.23"
	OEM	E9SZ-6375-C
	V6 3.8L Thunderbird, Cougar (89-95), V6 4.2L F-150 (97-08) (transmission AODE)	

AA-F245 	Dientes	132
	Contrapeso	No
	Diám Ext.	11.187"
	OEM	E1BZ-6375-B
	L6 200 Fairmont, Mustang, Thunderbird, Cougar (81-83) (transmission C3)	

AA-F246 	Dientes	155
	Contrapeso	Si
	Diám Ext.	15.681"
	OEM	F6TZ-6375-AA
	V8 7.3L (Navistar) Super Duty F-250, F-350, F-450 (95-03) (transmission E4OD)	

AA-F247 	Dientes	135
	Contrapeso	No
	Diám Ext.	11.88"
	OEM	F5DZ-6375-A
	V6 3.0L Windstar (95-00)	

AA-F248 	Dientes	138
	Contrapeso	No
	Diám Ext.	11.69"
	OEM	F5RZ-6375-C
	V6 2.5L DOHC Contour, Mystique (95-00)	

AA-F249 	Dientes	164
	Contrapeso	No
	Diám Ext.	14.23"
	OEM	F6AZ-6375-DA
	V8 4.6L F-150, F-250, Lobo, (97-02) (8 agujeros cigüeñal) (transmission 4R70W)	

AA-F250 	Dientes	164
	Contrapeso	No
	Diám Ext.	14.23"
	OEM	E3TZ-6375-G
	L6 300 (4.9L) F-100, F-150 (83-91) (transmission C5 / AOD)	











AA-F251 	Dientes	164
	Contrapeso	No
	Diám Ext.	14.23"
	OEM	F6AZ-6375-BA
	V8 4.6L Crown Victoria (96-08), F-150, Expedition (97-04) (6 agujeros cigüeñal)	

1.1 Aros dentados transmisión automática

Automatic transmission flex plates



Ford

 <p>AA-F252</p>	<table border="1"> <tr><td>Dientes</td><td>164</td></tr> <tr><td>Contrapeso</td><td>No</td></tr> <tr><td>Diám Ext.</td><td>14.13"</td></tr> <tr><td>OEM</td><td>1C3Z-6375-BA</td></tr> </table> <p>V8 5.4L F-150, F-250, Lobo (97-02) (transmision E4OD / 4R100)</p>	Dientes	164	Contrapeso	No	Diám Ext.	14.13"	OEM	1C3Z-6375-BA	 <p>AA-F253</p>	<table border="1"> <tr><td>Dientes</td><td>135</td></tr> <tr><td>Contrapeso</td><td>No</td></tr> <tr><td>Diám Ext.</td><td>11.300"</td></tr> <tr><td>OEM</td><td>F6DZ-6375-A</td></tr> </table> <p>V6 3.0L DOHC Taurus, Sable (96-05)</p>	Dientes	135	Contrapeso	No	Diám Ext.	11.300"	OEM	F6DZ-6375-A
Dientes	164																		
Contrapeso	No																		
Diám Ext.	14.13"																		
OEM	1C3Z-6375-BA																		
Dientes	135																		
Contrapeso	No																		
Diám Ext.	11.300"																		
OEM	F6DZ-6375-A																		
 <p>AA-F254</p>	<table border="1"> <tr><td>Dientes</td><td>138</td></tr> <tr><td>Contrapeso</td><td>No</td></tr> <tr><td>Diám Ext.</td><td>11.655"</td></tr> <tr><td>OEM</td><td>F77Z-6375-AA</td></tr> </table> <p>V6 4.0L Ranger, Explorer (97-02)</p>	Dientes	138	Contrapeso	No	Diám Ext.	11.655"	OEM	F77Z-6375-AA	 <p>AA-F255</p>	<table border="1"> <tr><td>Dientes</td><td>164</td></tr> <tr><td>Contrapeso</td><td>No</td></tr> <tr><td>Diám Ext.</td><td>14.23"</td></tr> <tr><td>OEM</td><td>4C3Z-6375-AA</td></tr> </table> <p>V8 5.4L (24 val.) Lobo, F-150, F-250, F-350 (05-10)</p>	Dientes	164	Contrapeso	No	Diám Ext.	14.23"	OEM	4C3Z-6375-AA
Dientes	138																		
Contrapeso	No																		
Diám Ext.	11.655"																		
OEM	F77Z-6375-AA																		
Dientes	164																		
Contrapeso	No																		
Diám Ext.	14.23"																		
OEM	4C3Z-6375-AA																		
 <p>AA-F256</p>	<table border="1"> <tr><td>Dientes</td><td>135</td></tr> <tr><td>Contrapeso</td><td>No</td></tr> <tr><td>Diám Ext.</td><td>11.88"</td></tr> <tr><td>OEM</td><td>1F2Z-6375-CA</td></tr> </table> <p>V6 3.8L Windstar (01-03), V6 3.9L, 4.2L Freestar (04-07)</p>	Dientes	135	Contrapeso	No	Diám Ext.	11.88"	OEM	1F2Z-6375-CA	 <p>AA-F257</p>	<table border="1"> <tr><td>Dientes</td><td>164</td></tr> <tr><td>Contrapeso</td><td>Si</td></tr> <tr><td>Diám Ext.</td><td>14.23"</td></tr> <tr><td>OEM</td><td>E3DZ-6375-A</td></tr> </table> <p>V6 232 LTD (1984) (transmision AOD)</p>	Dientes	164	Contrapeso	Si	Diám Ext.	14.23"	OEM	E3DZ-6375-A
Dientes	135																		
Contrapeso	No																		
Diám Ext.	11.88"																		
OEM	1F2Z-6375-CA																		
Dientes	164																		
Contrapeso	Si																		
Diám Ext.	14.23"																		
OEM	E3DZ-6375-A																		
 <p>AA-F258</p>	<table border="1"> <tr><td>Dientes</td><td>135</td></tr> <tr><td>Contrapeso</td><td>No</td></tr> <tr><td>Diám Ext.</td><td>11.29"</td></tr> <tr><td>OEM</td><td>E2FZ-6375-A</td></tr> </table> <p>L4 1.6L Escort (81-83)</p>	Dientes	135	Contrapeso	No	Diám Ext.	11.29"	OEM	E2FZ-6375-A	 <p>AA-F259</p>	<table border="1"> <tr><td>Dientes</td><td>112</td></tr> <tr><td>Contrapeso</td><td>No</td></tr> <tr><td>Diám Ext.</td><td>11.38"</td></tr> <tr><td>OEM</td><td>F42Z-6375-A</td></tr> </table> <p>L4 2.0L DOHC Probe (94-97)</p>	Dientes	112	Contrapeso	No	Diám Ext.	11.38"	OEM	F42Z-6375-A
Dientes	135																		
Contrapeso	No																		
Diám Ext.	11.29"																		
OEM	E2FZ-6375-A																		
Dientes	112																		
Contrapeso	No																		
Diám Ext.	11.38"																		
OEM	F42Z-6375-A																		
 <p>AA-F260</p>	<table border="1"> <tr><td>Dientes</td><td>135</td></tr> <tr><td>Contrapeso</td><td>No</td></tr> <tr><td>Diám Ext.</td><td>11.88"</td></tr> <tr><td>OEM</td><td>F5OY-6375-A</td></tr> </table> <p>V8 4.6L Lincoln Continental (98-02) (transmision AX4N)</p>	Dientes	135	Contrapeso	No	Diám Ext.	11.88"	OEM	F5OY-6375-A	 <p>AA-F261</p>	<table border="1"> <tr><td>Dientes</td><td>155</td></tr> <tr><td>Contrapeso</td><td>Si</td></tr> <tr><td>Diám Ext.</td><td>15.63"</td></tr> <tr><td>OEM</td><td>E9TZ-6375-A</td></tr> </table> <p>V8 7.3L (Navistar) F-250, F-350, F-450 (88-91)</p>	Dientes	155	Contrapeso	Si	Diám Ext.	15.63"	OEM	E9TZ-6375-A
Dientes	135																		
Contrapeso	No																		
Diám Ext.	11.88"																		
OEM	F5OY-6375-A																		
Dientes	155																		
Contrapeso	Si																		
Diám Ext.	15.63"																		
OEM	E9TZ-6375-A																		

1.1 Aros dentados transmisión automática

Automatic transmission flex plates





Ford

	Dientes	135
	Contrapeso	No
	Diám Ext.	11.25"
	OEM	F6DZ-6375-AB
	V6 3.4L Taurus (96-99)	

	Dientes	164
	Contrapeso	Si
	Diám Ext.	14.23"
	OEM	XR3Z-6375-CA
	V6 3.8L Mustang (98-04)	

	Dientes	132
	Contrapeso	Si
	Diám Ext.	11.25"
	OEM	FO2Z-6375-A
	L4 2.2L, V6 3.0L Probe (90-92)	

	Dientes	138
	Contrapeso	No
	Diám Ext.	11.25"
	OEM	1L2Z-6375-CA
	V6 4.0L Explorer, Mercury Mountainer (03-10)	

	Dientes	164
	Contrapeso	No
	Diám Ext.	14.23"
	OEM	4W7Z-6375-AA
	V8 4.6L F-150, F-250 Heritage (97-08), Mustang (96-04) (transmisión 4R70W / 4R75W)	

	Dientes	155
	Contrapeso	No
	Diám Ext.	15.68"
	OEM	F3TZ-6375-B
	V8 7.3L (Navistar) F-250, F-350, F-450 (92-96)	

	Dientes	164
	Contrapeso	No
	Diám Ext.	14.23"
	OEM	BL3Z-6375-A
	V6 3.5L, 3.7L, V8 5.0L F-150, Mustang (11-14)	

	Dientes	135
	Contrapeso	No
	Diám Ext.	11.25"
	OEM	F8CZ-6375-AA
	L4 2.0L DOHC Escort ZX2 (98-03), Contour, Mystique (95-00), Focus (00-04)	

	Dientes	141
	Contrapeso	Si
	Diám Ext.	14.28"
	OEM	3C3Z-6375-AA
	Ford F-250, F-350, F-450, F-550 Super Duty motores diesel V8 6.0L (03-07), V8 6.4L (08-10)	

	Dientes	112
	Contrapeso	No
	Diám Ext.	11.36"
	OEM	1S7Z-6375-C
	Focus 2.0L (05-07), 2.3L (03-06), Fusion 2.5L (10-15), 2.0L Ecoboost (13-15) Escape 2.0L Ecoboost (13-15) 2.3L (05-08), 2.5L (09-15)	

1.1 Aros dentados transmisión automática

Automatic transmission flex plates





Ford

	AA-F272	Dientes	138
		Contrapeso	No
		Diám Ext.	11.65"
		OEM	YL8Z-6375-AA
	Escape 2.0L Zetec (01-04), V6 3.0L (01-08), Mercury Mariner V6 3.0L (05-08)		

	AA-F273	Dientes	141
		Contrapeso	Si
		Diám Ext.	14.28"
		OEM	8C3Z-6375-A
	Ford F-250, F-350, F-450 V8 6.4L diesel (08-10)		

	AA-F274	Dientes	164
		Contrapeso	No
		Diám Ext.	14.23"
		OEM	1L2Z-6375-AA
	Ford Expedition V8 4.6L (2003), Explorer V8 4.6L (02-05), Lincoln Aviator V8 4.6L (03-05), Mercury Mountaineer V8 4.6L (02-05)		

	AA-F275	Dientes	164
		Contrapeso	No
		Diám Ext.	14.23"
		OEM	6L2Z-6375-AA
	Ford Explorer V8 4.6L (06-10), Explorer Sport Trac V8 4.6L (07-10), Pick up F-150 V8 4.6L (09-10)		

	AA-F276	Dientes	138
		Contrapeso	No
		Diám Ext.	11.69"
		OEM	4R3Z-6375-AA
	Ford Mustang V6 4.0L (05-10)		

	AA-F277	Dientes	135
		Contrapeso	No
		Diám Ext.	11.30"
		OEM	XS4Z-6375-EA
	Ford Focus 2.0L SOHC (00-04)		

	AA-F278	Dientes	132
		Contrapeso	No
		Diám Ext.	11.25"
		OEM	F1CZ-6375-A
	Ford Escort, Mercury Tracer 1.9L, 2.0L SOHC (91-02) OEM # F1CZ-6375-A		

1.1 Aros dentados transmisión automática

Automatic transmission flex plates

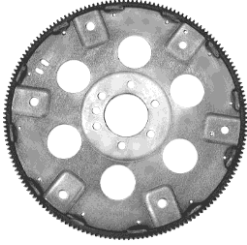

General Motors

	AA-G100	Dientes	168
		Contrapeso	No
		Diám Ext.	14.13"
		OEM	340296
	L6 250, V8 283, 305, 307, 350, 396, 402, 427 (66-81)		

	AA-G101	Dientes	168
		Contrapeso	Si
		Diám Ext.	14.13"
		OEM	340298
	V8 400 (small block) Chevrolet, GMC (70-80)		

	AA-G102	Dientes	168
		Contrapeso	Si
		Diám Ext.	14.13"
		OEM	343738
	V8 454 (70-76)		

	AA-G103	Dientes	153
		Contrapeso	No
		Diám Ext.	12.85"
		OEM	471591
	V6 220, 229, 262, L6 250, V8 262, 267, 305, 350 (79-85)		

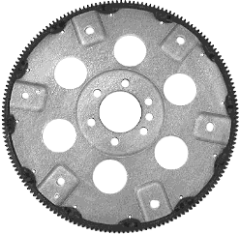
	AA-G104	Dientes	168
		Contrapeso	No
		Diám Ext.	14.13"
		OEM	471598
	L6 250, V8 283, 305, 307, 350, 396, 402, 427 (66-81)		

	AA-G105	Dientes	166
		Contrapeso	Si
		Diám Ext.	13.91"
		OEM	560712
	V8 260, 350, 403, 455 Oldsmobile, Pontiac (68-78)		

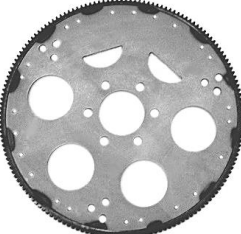
	AA-G106	Dientes	160
		Contrapeso	No
		Diám Ext.	13.42"
		OEM	1255728
	V6 231 Buick, Oldsmobile (75-77)		

	AA-G107	Dientes	160
		Contrapeso	Si
		Diám Ext.	13.42"
		OEM	1262989
	V8 300, 340, 350 (65-81) (motor Buick)		

	AA-G108	Dientes	166
		Contrapeso	Si
		Diám Ext.	13.91"
		OEM	22500807
	V8 260, 307, 350, 403 (79-90) (motor Oldsmobile)		









	AA-G109	Dientes	135
		Contrapeso	Si
		Diám Ext.	13.71
		OEM	22500808
	V8 260, 350 (78-85) (motor Oldsmobile diesel)		

1.1 Aros dentados transmisión automática

Automatic transmission flex plates

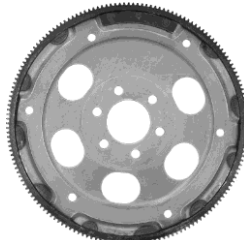

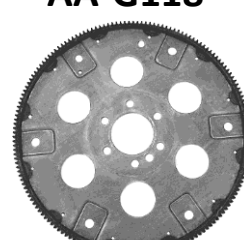
General Motors

 <p>AA-G110</p>	<table border="1"> <tr><td>Dientes</td><td>168</td></tr> <tr><td>Contrapeso</td><td>No</td></tr> <tr><td>Diám Ext.</td><td>14.13"</td></tr> <tr><td>OEM</td><td>361950</td></tr> <tr><td colspan="2">V8 283, 307, 350, 396, 427 (65-78) (transmision TH400)</td></tr> </table>	Dientes	168	Contrapeso	No	Diám Ext.	14.13"	OEM	361950	V8 283, 307, 350, 396, 427 (65-78) (transmision TH400)		 <p>AA-G111</p>	<table border="1"> <tr><td>Dientes</td><td>153</td></tr> <tr><td>Contrapeso</td><td>No</td></tr> <tr><td>Diám Ext.</td><td>12.85"</td></tr> <tr><td>OEM</td><td>471529</td></tr> <tr><td colspan="2">V6 220, 229, 262, L6 250, V8 262, 267, 305, 350 (79-85)</td></tr> </table>	Dientes	153	Contrapeso	No	Diám Ext.	12.85"	OEM	471529	V6 220, 229, 262, L6 250, V8 262, 267, 305, 350 (79-85)	
Dientes	168																						
Contrapeso	No																						
Diám Ext.	14.13"																						
OEM	361950																						
V8 283, 307, 350, 396, 427 (65-78) (transmision TH400)																							
Dientes	153																						
Contrapeso	No																						
Diám Ext.	12.85"																						
OEM	471529																						
V6 220, 229, 262, L6 250, V8 262, 267, 305, 350 (79-85)																							
 <p>AA-G112</p>	<table border="1"> <tr><td>Dientes</td><td>166</td></tr> <tr><td>Contrapeso</td><td>No</td></tr> <tr><td>Diám Ext.</td><td>13.96"</td></tr> <tr><td>OEM</td><td>487651</td></tr> <tr><td colspan="2">V8 326, 350, 389, 400, 421, 428, 455 (65-76) (motor Pontiac)</td></tr> </table>	Dientes	166	Contrapeso	No	Diám Ext.	13.96"	OEM	487651	V8 326, 350, 389, 400, 421, 428, 455 (65-76) (motor Pontiac)		 <p>AA-G113</p>	<table border="1"> <tr><td>Dientes</td><td>142</td></tr> <tr><td>Contrapeso</td><td>No</td></tr> <tr><td>Diám Ext.</td><td>11.95"</td></tr> <tr><td>OEM</td><td>10031262</td></tr> <tr><td colspan="2">L4 151 Buick, Chevrolet, Oldsmobile, Pontiac (80-92)</td></tr> </table>	Dientes	142	Contrapeso	No	Diám Ext.	11.95"	OEM	10031262	L4 151 Buick, Chevrolet, Oldsmobile, Pontiac (80-92)	
Dientes	166																						
Contrapeso	No																						
Diám Ext.	13.96"																						
OEM	487651																						
V8 326, 350, 389, 400, 421, 428, 455 (65-76) (motor Pontiac)																							
Dientes	142																						
Contrapeso	No																						
Diám Ext.	11.95"																						
OEM	10031262																						
L4 151 Buick, Chevrolet, Oldsmobile, Pontiac (80-92)																							
 <p>AA-G114</p>	<table border="1"> <tr><td>Dientes</td><td>166</td></tr> <tr><td>Contrapeso</td><td>Si</td></tr> <tr><td>Diám Ext.</td><td>13.96"</td></tr> <tr><td>OEM</td><td>10005639</td></tr> <tr><td colspan="2">V8 301 Pontiac (77-78)</td></tr> </table>	Dientes	166	Contrapeso	Si	Diám Ext.	13.96"	OEM	10005639	V8 301 Pontiac (77-78)		 <p>AA-G115</p>	<table border="1"> <tr><td>Dientes</td><td>166</td></tr> <tr><td>Contrapeso</td><td>Si</td></tr> <tr><td>Diám Ext.</td><td>13.96"</td></tr> <tr><td>OEM</td><td>10009275</td></tr> <tr><td colspan="2">V8 265, 301 Buick, Pontiac (79-81) (Contrapeso grueso)</td></tr> </table>	Dientes	166	Contrapeso	Si	Diám Ext.	13.96"	OEM	10009275	V8 265, 301 Buick, Pontiac (79-81) (Contrapeso grueso)	
Dientes	166																						
Contrapeso	Si																						
Diám Ext.	13.96"																						
OEM	10005639																						
V8 301 Pontiac (77-78)																							
Dientes	166																						
Contrapeso	Si																						
Diám Ext.	13.96"																						
OEM	10009275																						
V8 265, 301 Buick, Pontiac (79-81) (Contrapeso grueso)																							
 <p>AA-G116</p>	<table border="1"> <tr><td>Dientes</td><td>166</td></tr> <tr><td>Contrapeso</td><td>No</td></tr> <tr><td>Diám Ext.</td><td>13.96"</td></tr> <tr><td>OEM</td><td>10005640</td></tr> <tr><td colspan="2">V8 350, 400 Pontiac (76-78)</td></tr> </table>	Dientes	166	Contrapeso	No	Diám Ext.	13.96"	OEM	10005640	V8 350, 400 Pontiac (76-78)		 <p>AA-G117</p>	<table border="1"> <tr><td>Dientes</td><td>168</td></tr> <tr><td>Contrapeso</td><td>Si</td></tr> <tr><td>Diám Ext.</td><td>14.13"</td></tr> <tr><td>OEM</td><td>14001992</td></tr> <tr><td colspan="2">V8 454 Chevrolet, GMC (73-90)</td></tr> </table>	Dientes	168	Contrapeso	Si	Diám Ext.	14.13"	OEM	14001992	V8 454 Chevrolet, GMC (73-90)	
Dientes	166																						
Contrapeso	No																						
Diám Ext.	13.96"																						
OEM	10005640																						
V8 350, 400 Pontiac (76-78)																							
Dientes	168																						
Contrapeso	Si																						
Diám Ext.	14.13"																						
OEM	14001992																						
V8 454 Chevrolet, GMC (73-90)																							
 <p>AA-G118</p>	<table border="1"> <tr><td>Dientes</td><td>168</td></tr> <tr><td>Contrapeso</td><td>No</td></tr> <tr><td>Diám Ext.</td><td>14.13"</td></tr> <tr><td>OEM</td><td>562949</td></tr> <tr><td colspan="2">V8 350 Chevrolet, GMC (79-85) (transmisión TH400)</td></tr> </table>	Dientes	168	Contrapeso	No	Diám Ext.	14.13"	OEM	562949	V8 350 Chevrolet, GMC (79-85) (transmisión TH400)		 <p>AA-G119</p>	<table border="1"> <tr><td>Dientes</td><td>168</td></tr> <tr><td>Contrapeso</td><td>Si</td></tr> <tr><td>Diám Ext.</td><td>14.13"</td></tr> <tr><td>OEM</td><td>336717</td></tr> <tr><td colspan="2">V8 454 Chevrolet, GMC (70-78)</td></tr> </table>	Dientes	168	Contrapeso	Si	Diám Ext.	14.13"	OEM	336717	V8 454 Chevrolet, GMC (70-78)	
Dientes	168																						
Contrapeso	No																						
Diám Ext.	14.13"																						
OEM	562949																						
V8 350 Chevrolet, GMC (79-85) (transmisión TH400)																							
Dientes	168																						
Contrapeso	Si																						
Diám Ext.	14.13"																						
OEM	336717																						
V8 454 Chevrolet, GMC (70-78)																							

1.1 Aros dentados transmisión automática

Automatic transmission flex plates





General Motors

AA-G120 	Dientes	162
	Contrapeso	Si
	Diám Ext.	13.65"
	OEM	562949
	V8 307, 350 Buick, Cadillac, Oldsmobile (79-85) (motor Oldsmobile)	

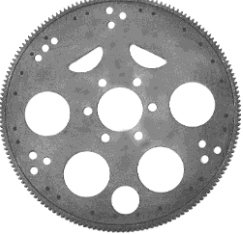
AA-G121 	Dientes	166
	Contrapeso	No
	Diám Ext.	13.96"
	OEM	1616534
	V8 368, 425, 472, 500, Cadillac (68-84)	

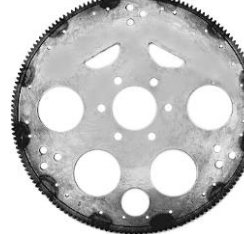
AA-G122 	Dientes	160
	Contrapeso	No
	Diám Ext.	13.42"
	OEM	1257040
	V6 196 Buick, Chevrolet (1978)	

AA-G123 	Dientes	160
	Contrapeso	No
	Diám Ext.	13.42"
	OEM	1257041
	V6 231 Buick, Chevrolet, Oldsmobile, Pontiac (77-78)	

AA-G124 	Dientes	160
	Contrapeso	No
	Diám Ext.	13.42"
	OEM	25501867
	V6 231, 252 Buick, Chevrolet, Cadillac, Oldsmobile, Pontiac (77-80)	

AA-G125 	Dientes	160
	Contrapeso	No
	Diám Ext.	13.42"
	OEM	25501868
	V6 231 Buick, Chevrolet (79-80)	

AA-G126 	Dientes	160
	Contrapeso	No
	Diám Ext.	13.42"
	OEM	25501869
	V6 196 Buick, Chevrolet (1979)	

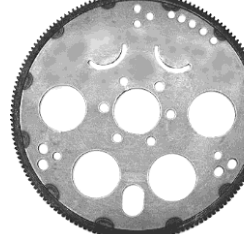
AA-G127 	Dientes	162
	Contrapeso	No
	Diám Ext.	13.63"
	OEM	25501870
	V6 231 Buick (79-80)	

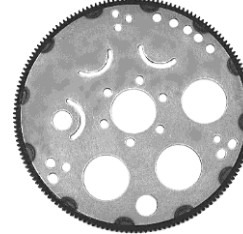
AA-G128 	Dientes	160
	Contrapeso	No
	Diám Ext.	13.42"
	OEM	25512346
	V6 231 Buick, Chevrolet, Oldsmobile, Pontiac (80-83)	

AA-G129 	Dientes	162
	Contrapeso	No
	Diám Ext.	13.63"
	OEM	25512347
	V6 231 Buick (81-85)	

1.1 Aros dentados transmisión automática

Automatic transmission flex plates



General Motors

	Dientes	160
	Contrapeso	No
	Diám Ext.	13.42"
	OEM	25512348
	V6 231, 252 Buick, Chevrolet, Cadillac, Oldsmobile, Pontiac (81-87)	

	Dientes	162
	Contrapeso	No
	Diám Ext.	13.63"
	OEM	25512349
	V6 252 Buick, Cadillac, Oldsmobile (81-84)	

	Dientes	160
	Contrapeso	No
	Diám Ext.	13.42"
	OEM	25512350
	V6 231 Buick, Chevrolet (81-87)	

	Dientes	139
	Contrapeso	Si
	Diám Ext.	14.13"
	OEM	14077157
	V8 379 (6.2L), 395 (6.5L) diesel Chevrolet, GMC, Hummer (82-03) (transmisión TH400 / 4L80E)	

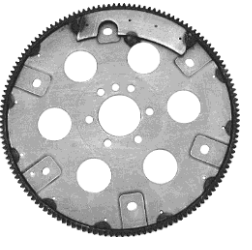
	Dientes	139
	Contrapeso	Si
	Diám Ext.	14.13"
	OEM	14077158
	V8 379 (6.2L), 395 (6.5L) diesel Chevrolet, GMC, Hummer (82-95) (transmisión TH700 / 4L60E)	

	Dientes	142
	Contrapeso	No
	Diám Ext.	11.98"
	OEM	14001182
	L4 98 Chevrolet Chevette, Pontiac T1000 (79-87)	

	Dientes	142
	Contrapeso	No
	Diám Ext.	11.87"
	OEM	14018713
	L4 2.0L (122), 2.2L (134), V6 2.8L (173), 3.1L (189), 3.4L (207) Buick, Chevrolet, Isuzu, Oldsmobile, Pontiac (82-96)	

	Dientes	142
	Contrapeso	Si
	Diám Ext.	11.87"
	OEM	14085471
	V6 173 Buick, Cadillac, Chevrolet, Oldsmobile, Pontiac (82-87)	

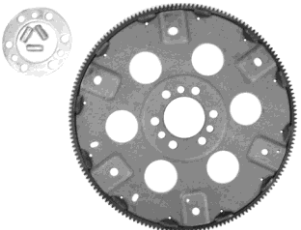
	Dientes	168
	Contrapeso	No
	Diám Ext.	14.13"
	OEM	361051
	L6 292 Chevrolet pick ups (75-78) (transmisión TH350)	

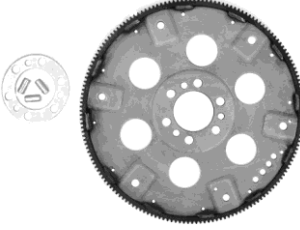
	Dientes	168
	Contrapeso	No
	Diám Ext.	14.13"
	OEM	361052
	L6 292 Chevrolet pick ups (67-78) (transmisión TH400)	





1.1 Aros dentados transmisión automática

Automatic transmission flex plates



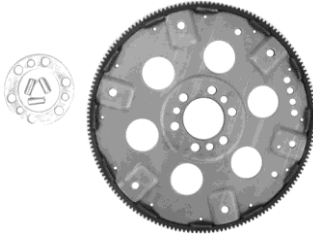

General Motors

	AA-G140	Dientes	168
		Contrapeso	No
		Diám Ext.	14.13"
		OEM	14002590
	L6 292 Chevrolet pick ups (79-89) (transmisión TH400)		

	AA-G141	Dientes	153
		Contrapeso	Si
		Diám Ext.	12.85"
		OEM	14088765
	V6 4.3L (262), V8 5.0L (305), 5.7L (350) autos Buick, Cadillac, Chevrolet, Oldsmobile, Pontiac (86-97)		

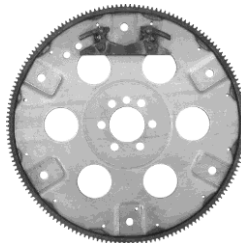
	AA-G142	Dientes	168
		Contrapeso	Si
		Diám Ext.	14.13"
		OEM	14088761
	V6 4.3L (262), V8 5.0L (305), 5.7L (350) Pick ups Chevrolet, GMC, Express 1500 (86-02), Isuzu Hombre (96-98) (transmisión TH700 / 4L60E)		

	AA-G143	Dientes	168
		Contrapeso	Si
		Diám Ext.	14.13"
		OEM	14088767
	V6 4.3L (262), V8 5.0L (305), 5.7L (350) Pick ups Chevrolet, GMC, Express 1500 (86-02) (transmisión 4L80 / 4L80E)		

	AA-G144	Dientes	142
		Contrapeso	No
		Diám Ext.	11.87"
		OEM	10004282
	L4 151 Buick, Chevrolet, Oldsmobile, Pontiac (80-81)		

	AA-G145	Dientes	142
		Contrapeso	Si
		Diám Ext.	11.87"
		OEM	14033245
	V6 173 Buick, Chevrolet, Oldsmobile, Pontiac (80-81)		

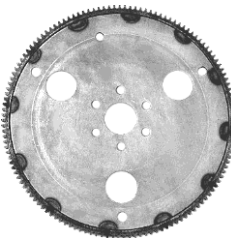
	AA-G146	Dientes	135
		Contrapeso	No
		Diám Ext.	11.375"
		OEM	10018740
	112 (1.8L), 122 (2.0L) Buick, Oldsmobile, Pontiac (82-94)		

	AA-G147	Dientes	148
		Contrapeso	Si
		Diám Ext.	12.40"
		OEM	14085472
	V6 173 Pick up S-10, S-15 (83-87), Camaro (82-87)		

	AA-G148	Dientes	148
		Contrapeso	No
		Diám Ext.	12.40"
		OEM	10044373
	L4 151 (2.5L) Pick up S-10, S-15 (85-93)		









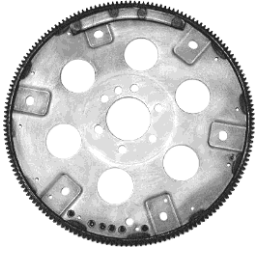

	AA-G149	Dientes	148
		Contrapeso	No
		Diám Ext.	12.40"
		OEM	14100557
	V6 173 (2.8L), 189 (3.1L) Pick up S-10, S-15 (88-93), Camaro (88-92)		

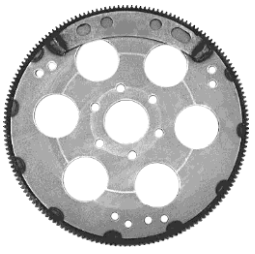
1.1 Aros dentados transmisión automática

Automatic transmission flex plates



General Motors











<p>AA-G150</p> 	<table border="1"> <tr><td>Dientes</td><td>168</td></tr> <tr><td>Contrapeso</td><td>Si</td></tr> <tr><td>Diám Ext.</td><td>14.13"</td></tr> <tr><td>OEM</td><td>340298</td></tr> <tr><td colspan="2">V8 400 (small block) Chevrolet, GMC (70-80)</td></tr> </table>	Dientes	168	Contrapeso	Si	Diám Ext.	14.13"	OEM	340298	V8 400 (small block) Chevrolet, GMC (70-80)		<p>AA-G151</p> 	<table border="1"> <tr><td>Dientes</td><td>162</td></tr> <tr><td>Contrapeso</td><td>No</td></tr> <tr><td>Diám Ext.</td><td>13.63"</td></tr> <tr><td>OEM</td><td>1623936</td></tr> <tr><td colspan="2">V8 252 Cadillac DeVille, El Dorado, Seville (82-85)</td></tr> </table>	Dientes	162	Contrapeso	No	Diám Ext.	13.63"	OEM	1623936	V8 252 Cadillac DeVille, El Dorado, Seville (82-85)	
Dientes	168																						
Contrapeso	Si																						
Diám Ext.	14.13"																						
OEM	340298																						
V8 400 (small block) Chevrolet, GMC (70-80)																							
Dientes	162																						
Contrapeso	No																						
Diám Ext.	13.63"																						
OEM	1623936																						
V8 252 Cadillac DeVille, El Dorado, Seville (82-85)																							
<p>AA-G152</p> 	<table border="1"> <tr><td>Dientes</td><td>166</td></tr> <tr><td>Contrapeso</td><td>Si</td></tr> <tr><td>Diám Ext.</td><td>14.00"</td></tr> <tr><td>OEM</td><td>1233837</td></tr> <tr><td colspan="2">V8 455 Buick Riviera, Electra (70-76)</td></tr> </table>	Dientes	166	Contrapeso	Si	Diám Ext.	14.00"	OEM	1233837	V8 455 Buick Riviera, Electra (70-76)		<p>AA-G153</p> 	<table border="1"> <tr><td>Dientes</td><td>153</td></tr> <tr><td>Contrapeso</td><td>No</td></tr> <tr><td>Diám Ext.</td><td>12.93"</td></tr> <tr><td>OEM</td><td>10006988</td></tr> <tr><td colspan="2">L4 151 Chevrolet, Oldsmobile, Pontiac (77-79)</td></tr> </table>	Dientes	153	Contrapeso	No	Diám Ext.	12.93"	OEM	10006988	L4 151 Chevrolet, Oldsmobile, Pontiac (77-79)	
Dientes	166																						
Contrapeso	Si																						
Diám Ext.	14.00"																						
OEM	1233837																						
V8 455 Buick Riviera, Electra (70-76)																							
Dientes	153																						
Contrapeso	No																						
Diám Ext.	12.93"																						
OEM	10006988																						
L4 151 Chevrolet, Oldsmobile, Pontiac (77-79)																							
<p>AA-G154</p> 	<table border="1"> <tr><td>Dientes</td><td>153</td></tr> <tr><td>Contrapeso</td><td>No</td></tr> <tr><td>Diám Ext.</td><td>12.93"</td></tr> <tr><td>OEM</td><td>10004033</td></tr> <tr><td colspan="2">L4 151 Chevrolet, Oldsmobile, Pontiac (78-80)</td></tr> </table>	Dientes	153	Contrapeso	No	Diám Ext.	12.93"	OEM	10004033	L4 151 Chevrolet, Oldsmobile, Pontiac (78-80)		<p>AA-G155</p> 	<table border="1"> <tr><td>Dientes</td><td>135</td></tr> <tr><td>Contrapeso</td><td>No</td></tr> <tr><td>Diám Ext.</td><td>11.375"</td></tr> <tr><td>OEM</td><td>14076414</td></tr> <tr><td colspan="2">L4 122 (2.0L) Pontiac Grand Am (87-89), Lemans (89-90)</td></tr> </table>	Dientes	135	Contrapeso	No	Diám Ext.	11.375"	OEM	14076414	L4 122 (2.0L) Pontiac Grand Am (87-89), Lemans (89-90)	
Dientes	153																						
Contrapeso	No																						
Diám Ext.	12.93"																						
OEM	10004033																						
L4 151 Chevrolet, Oldsmobile, Pontiac (78-80)																							
Dientes	135																						
Contrapeso	No																						
Diám Ext.	11.375"																						
OEM	14076414																						
L4 122 (2.0L) Pontiac Grand Am (87-89), Lemans (89-90)																							
<p>AA-G156</p> 	<table border="1"> <tr><td>Dientes</td><td>162</td></tr> <tr><td>Contrapeso</td><td>No</td></tr> <tr><td>Diám Ext.</td><td>13.63"</td></tr> <tr><td>OEM</td><td>1618098</td></tr> <tr><td colspan="2">V8 368 Cadillac El Dorado, Seville (80-81)</td></tr> </table>	Dientes	162	Contrapeso	No	Diám Ext.	13.63"	OEM	1618098	V8 368 Cadillac El Dorado, Seville (80-81)		<p>AA-G157</p> 	<table border="1"> <tr><td>Dientes</td><td>168</td></tr> <tr><td>Contrapeso</td><td>Si</td></tr> <tr><td>Diám Ext.</td><td>14.13"</td></tr> <tr><td>OEM</td><td>10101170</td></tr> <tr><td colspan="2">V8 7.4L (454) Pick up C1500, C2500, C3500, Suburban (91-00)</td></tr> </table>	Dientes	168	Contrapeso	Si	Diám Ext.	14.13"	OEM	10101170	V8 7.4L (454) Pick up C1500, C2500, C3500, Suburban (91-00)	
Dientes	162																						
Contrapeso	No																						
Diám Ext.	13.63"																						
OEM	1618098																						
V8 368 Cadillac El Dorado, Seville (80-81)																							
Dientes	168																						
Contrapeso	Si																						
Diám Ext.	14.13"																						
OEM	10101170																						
V8 7.4L (454) Pick up C1500, C2500, C3500, Suburban (91-00)																							
<p>AA-G158</p> 	<table border="1"> <tr><td>Dientes</td><td>142</td></tr> <tr><td>Contrapeso</td><td>Si</td></tr> <tr><td>Diám Ext.</td><td>11.91"</td></tr> <tr><td>OEM</td><td>25535388</td></tr> <tr><td colspan="2">V6 3.3L (204) Buick Century, Cutlass Ciera (89-90)</td></tr> </table>	Dientes	142	Contrapeso	Si	Diám Ext.	11.91"	OEM	25535388	V6 3.3L (204) Buick Century, Cutlass Ciera (89-90)		<p>AA-G159</p> 	<table border="1"> <tr><td>Dientes</td><td>142</td></tr> <tr><td>Contrapeso</td><td>Si</td></tr> <tr><td>Diám Ext.</td><td>11.91"</td></tr> <tr><td>OEM</td><td>25534065</td></tr> <tr><td colspan="2">V6 3.8L (231) Buick Electra, Riviera, Delta 88, Bonneville (88-90)</td></tr> </table>	Dientes	142	Contrapeso	Si	Diám Ext.	11.91"	OEM	25534065	V6 3.8L (231) Buick Electra, Riviera, Delta 88, Bonneville (88-90)	
Dientes	142																						
Contrapeso	Si																						
Diám Ext.	11.91"																						
OEM	25535388																						
V6 3.3L (204) Buick Century, Cutlass Ciera (89-90)																							
Dientes	142																						
Contrapeso	Si																						
Diám Ext.	11.91"																						
OEM	25534065																						
V6 3.8L (231) Buick Electra, Riviera, Delta 88, Bonneville (88-90)																							

1.1 Aros dentados transmisión automática

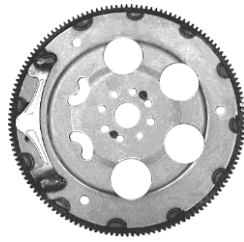
Automatic transmission flex plates



General Motors

<p>AA-G160</p> 	<table border="1"> <tr><td>Dientes</td><td>142</td></tr> <tr><td>Contrapeso</td><td>Si</td></tr> <tr><td>Diám Ext.</td><td>11.91"</td></tr> <tr><td>OEM</td><td>25517709</td></tr> <tr><td colspan="2">V6 181 (3.0L) Buick Century, Cutlass Ciera (83-85)</td></tr> </table>	Dientes	142	Contrapeso	Si	Diám Ext.	11.91"	OEM	25517709	V6 181 (3.0L) Buick Century, Cutlass Ciera (83-85)		<p>AA-G161</p> 	<table border="1"> <tr><td>Dientes</td><td>142</td></tr> <tr><td>Contrapeso</td><td>Si</td></tr> <tr><td>Diám Ext.</td><td>11.91"</td></tr> <tr><td>OEM</td><td>25512172</td></tr> <tr><td colspan="2">V6 181 (3.0L) Buick Century, Cutlass Ciera (82-83)</td></tr> </table>	Dientes	142	Contrapeso	Si	Diám Ext.	11.91"	OEM	25512172	V6 181 (3.0L) Buick Century, Cutlass Ciera (82-83)	
Dientes	142																						
Contrapeso	Si																						
Diám Ext.	11.91"																						
OEM	25517709																						
V6 181 (3.0L) Buick Century, Cutlass Ciera (83-85)																							
Dientes	142																						
Contrapeso	Si																						
Diám Ext.	11.91"																						
OEM	25512172																						
V6 181 (3.0L) Buick Century, Cutlass Ciera (82-83)																							
<p>AA-G162</p> 	<table border="1"> <tr><td>Dientes</td><td>142</td></tr> <tr><td>Contrapeso</td><td>Si</td></tr> <tr><td>Diám Ext.</td><td>11.91"</td></tr> <tr><td>OEM</td><td>25523510</td></tr> <tr><td colspan="2">V6 181 (3.0L) Pontiac Grand Am, Delta 88 (85-88)</td></tr> </table>	Dientes	142	Contrapeso	Si	Diám Ext.	11.91"	OEM	25523510	V6 181 (3.0L) Pontiac Grand Am, Delta 88 (85-88)		<p>AA-G163</p> 	<table border="1"> <tr><td>Dientes</td><td>142</td></tr> <tr><td>Contrapeso</td><td>Si</td></tr> <tr><td>Diám Ext.</td><td>11.91"</td></tr> <tr><td>OEM</td><td>25515222</td></tr> <tr><td colspan="2">V6 231 (3.8L) Buick Century, Electra, Cutlass Ciera (84-88)</td></tr> </table>	Dientes	142	Contrapeso	Si	Diám Ext.	11.91"	OEM	25515222	V6 231 (3.8L) Buick Century, Electra, Cutlass Ciera (84-88)	
Dientes	142																						
Contrapeso	Si																						
Diám Ext.	11.91"																						
OEM	25523510																						
V6 181 (3.0L) Pontiac Grand Am, Delta 88 (85-88)																							
Dientes	142																						
Contrapeso	Si																						
Diám Ext.	11.91"																						
OEM	25515222																						
V6 231 (3.8L) Buick Century, Electra, Cutlass Ciera (84-88)																							
<p>AA-G164</p> 	<table border="1"> <tr><td>Dientes</td><td>142</td></tr> <tr><td>Contrapeso</td><td>Si</td></tr> <tr><td>Diám Ext.</td><td>11.91"</td></tr> <tr><td>OEM</td><td>24501451</td></tr> <tr><td colspan="2">V6 3.8L Buick Regal (90-94), Oldsmobile Silhouette (90-92), Pontiac Trans Sport (90-92)</td></tr> </table>	Dientes	142	Contrapeso	Si	Diám Ext.	11.91"	OEM	24501451	V6 3.8L Buick Regal (90-94), Oldsmobile Silhouette (90-92), Pontiac Trans Sport (90-92)		<p>AA-G165</p> 	<table border="1"> <tr><td>Dientes</td><td>135</td></tr> <tr><td>Contrapeso</td><td>Si</td></tr> <tr><td>Diám Ext.</td><td>13.71"</td></tr> <tr><td>OEM</td><td>22512002</td></tr> <tr><td colspan="2">V6 262 Buick Regal, Cutlass Supreme (82-85) (motor diesel Oldsmobile)</td></tr> </table>	Dientes	135	Contrapeso	Si	Diám Ext.	13.71"	OEM	22512002	V6 262 Buick Regal, Cutlass Supreme (82-85) (motor diesel Oldsmobile)	
Dientes	142																						
Contrapeso	Si																						
Diám Ext.	11.91"																						
OEM	24501451																						
V6 3.8L Buick Regal (90-94), Oldsmobile Silhouette (90-92), Pontiac Trans Sport (90-92)																							
Dientes	135																						
Contrapeso	Si																						
Diám Ext.	13.71"																						
OEM	22512002																						
V6 262 Buick Regal, Cutlass Supreme (82-85) (motor diesel Oldsmobile)																							
<p>AA-G166</p> 	<table border="1"> <tr><td>Dientes</td><td>148</td></tr> <tr><td>Contrapeso</td><td>No</td></tr> <tr><td>Diám Ext.</td><td>12.40"</td></tr> <tr><td>OEM</td><td>14097667</td></tr> <tr><td colspan="2">V6 3.4L Chevrolet Camaro, Pontiac Firebird (92-95)</td></tr> </table>	Dientes	148	Contrapeso	No	Diám Ext.	12.40"	OEM	14097667	V6 3.4L Chevrolet Camaro, Pontiac Firebird (92-95)		<p>AA-G167</p> 	<table border="1"> <tr><td>Dientes</td><td>142</td></tr> <tr><td>Contrapeso</td><td>Si</td></tr> <tr><td>Diám Ext.</td><td>11.91"</td></tr> <tr><td>OEM</td><td>24501753</td></tr> <tr><td colspan="2">V6 3.8L Oldsmobile 98 Regency (92-95), LSS (96-99)</td></tr> </table>	Dientes	142	Contrapeso	Si	Diám Ext.	11.91"	OEM	24501753	V6 3.8L Oldsmobile 98 Regency (92-95), LSS (96-99)	
Dientes	148																						
Contrapeso	No																						
Diám Ext.	12.40"																						
OEM	14097667																						
V6 3.4L Chevrolet Camaro, Pontiac Firebird (92-95)																							
Dientes	142																						
Contrapeso	Si																						
Diám Ext.	11.91"																						
OEM	24501753																						
V6 3.8L Oldsmobile 98 Regency (92-95), LSS (96-99)																							
<p>AA-G168</p> 	<table border="1"> <tr><td>Dientes</td><td>142</td></tr> <tr><td>Contrapeso</td><td>Si</td></tr> <tr><td>Diám Ext.</td><td>11.91"</td></tr> <tr><td>OEM</td><td>24502775</td></tr> <tr><td colspan="2">V6 3.3L Century, Cutlass Ciera, Pontiac Grand Am (92-93)</td></tr> </table>	Dientes	142	Contrapeso	Si	Diám Ext.	11.91"	OEM	24502775	V6 3.3L Century, Cutlass Ciera, Pontiac Grand Am (92-93)		<p>AA-G168SC</p> 	<table border="1"> <tr><td>Dientes</td><td>142</td></tr> <tr><td>Contrapeso</td><td>No</td></tr> <tr><td>Diám Ext.</td><td>11.91"</td></tr> <tr><td>OEM</td><td>24502768</td></tr> <tr><td colspan="2">V6 3.3L Buick Century, Oldsmobile Cutlass, Pontiac Grand Am (sin contrapeso)</td></tr> </table>	Dientes	142	Contrapeso	No	Diám Ext.	11.91"	OEM	24502768	V6 3.3L Buick Century, Oldsmobile Cutlass, Pontiac Grand Am (sin contrapeso)	
Dientes	142																						
Contrapeso	Si																						
Diám Ext.	11.91"																						
OEM	24502775																						
V6 3.3L Century, Cutlass Ciera, Pontiac Grand Am (92-93)																							
Dientes	142																						
Contrapeso	No																						
Diám Ext.	11.91"																						
OEM	24502768																						
V6 3.3L Buick Century, Oldsmobile Cutlass, Pontiac Grand Am (sin contrapeso)																							

1.1 Aros dentados transmisión automática

Automatic transmission flex plates





General Motors

AA-G169 	Dientes	142
	Contrapeso	Si
	Diám Ext.	11.91"
	OEM	24501453
	V6 3.3L Buick Century, Cutlass Ciera, Pontiac Grand Am (91-92)	

AA-G170 	Dientes	142
	Contrapeso	No
	Diám Ext.	11.91"
	OEM	22533252
	L4 2.3L, 2.4L Cavalier, Malibu, Cutlass, Grand Am, Grand Prix, Sunfire (88-99)	

AA-G171 	Dientes	142
	Contrapeso	No
	Diám Ext.	11.91"
	OEM	24575991
	L4 2.2L Pick up S-10 (94-03), GMC Sonoma (94-03), Isuzu Hombre (97-00)	

AA-G172 	Dientes	142
	Contrapeso	No
	Diám Ext.	11.87"
	OEM	24576876
	L4 2.2L Cavalier (96-01), Impala V6 3.4L, 3.5L, 3.9L (00-10), Malibu V6 3.1L, 3.5L, 3.9L (99-09), Uplander V6 3.5L, 3.9L (05-07)	

AA-G173 	Dientes	142
	Contrapeso	No
	Diám Ext.	11.91"
	OEM	1648458
	V8 4.1L, 4.5L Cadillac Deville, El Dorado, Seville (85-92)	

AA-G174 	Dientes	166
	Contrapeso	No
	Diám Ext.	13.96"
	OEM	1481894
	V8 429 Cadillac (65-67)	

AA-G175 	Dientes	142
	Contrapeso	Si
	Diám Ext.	11.91"
	OEM	24508110
	V6 3.8L Buick Lacrosse (05-09), Lesabre (96-05), Impala (00-05), Monte Carlo (96-05), Oldsmobile Intrigue (98-99), Pontiac Grand Prix (04-08)	

AA-G176 	Dientes	142
	Contrapeso	No
	Diám Ext.	11.91"
	OEM	12579453
	V6 3.5L, 3.9L Impala (07-11), Malibu (08-10), Uplander (08-09)	

AA-G177 	Dientes	135
	Contrapeso	No
	Diám Ext.	11.32"
	OEM	96488000
	L4 1.6L Aveo LT, LS (04-08), Aveo5 LS (07-08)	

AA-G178 	Dientes	161
	Contrapeso	No
	Diám Ext.	13.56"
	OEM	12576272
	Trailblazer LS, LT L6 4.2L (02-08), Buick Rainier L6 4.2L (04-07)	

1.1 Aros dentados transmisión automática

Automatic transmission flex plates



General Motors

AA-G180 	Dientes	168
	Contrapeso	No
	Diám Ext.	14.13"
	OEM	12551367
	V8 4.8L, 5.3L, 6.0L Silverado, Yukon, Sierra, Avalanche, Express 1500 (03-10) (transmisión 4L80E / 4L85E) (sin espaciador)	

AA-G182 	Dientes	168
	Contrapeso	Si
	Diám Ext.	14.13
	OEM	12555640
	V6 4.3L Silverado 1500 (99-10), GMC Sierra 1500 (99-10), (trans. 4L60E / 4L65E)	

AA-G183 	Dientes	168
	Contrapeso	Si
	Diám Ext.	14.135"
	OEM	12557584
	V6 4.3L, V8 5.7L C1500, C2500, Silverado (96-02) (transmisión 4L80E)	

AA-G184 	Dientes	168
	Contrapeso	Si
	Diám Ext.	14.13"
	OEM	12557587
	V6 4.3L S-10, Silverado, Van Express 1500 (97-02) (transmisión 4L60E)	

AA-G185 	Dientes	168
	Contrapeso	No
	Diám Ext.	14.13"
	OEM	12561217
	V8 8.1L Suburban, Silverado, Yukon, GMC Sierra, Avalanche (01-07)	

AA-G186 	Dientes	168
	Contrapeso	No
	Diám Ext.	14.13"
	OEM	12606620 / 12580709
	V8 4.8L, 5.3L, 6.0L, 6.2L Cheyenne, Silverado 2500, Avalanche, GMC Sierra 2500, Cadillac Escalade (03-14)	

AA-G187 	Dientes	168
	Contrapeso	No
	Diám Ext.	14.13"
	OEM	12621399
	V8 4.8L, 5.3L, 6.0L, 6.2L Silverado, Yukon, Sierra, Avalanche, Express 1500 (03-14) (transmisión 4L80E / 4L85E) (con espaciador)	

AA-G188 	Dientes	142
	Contrapeso	No
	Diám Ext.	11.91"
	OEM	3544671
	V8 4.6L Cadillac DeVille, Seville SLS, STS, Eldorado (93-02)	

AA-G189 	Dientes	135
	Contrapeso	No
	Diám Ext.	11.32"
	OEM	90236309
	L4 1.6L Chevy Monza, Chevy C2 (98-10), Aveo 1.6L (08-14), Astra 1.8L (01-03)	











AA-G190 	Dientes	142
	Contrapeso	Si
	Diám Ext.	11.91"
	OEM	12609154
	V6 3.8L Impala SS, Montecarlo SS, Grand Prix GTP, supercargados (97-05)	

1.1 Aros dentados transmisión automática

Automatic transmission flex plates



General Motors

	<table border="1"> <tr><td>Dientes</td><td>142</td></tr> <tr><td>Contrapeso</td><td>No</td></tr> <tr><td>Diám Ext.</td><td>11.91"</td></tr> <tr><td>OEM</td><td>12575076</td></tr> <tr><td colspan="2">V6 3.4L, 3.6L Chevrolet Equinox, Pontiac Torrent (05-09)</td></tr> </table>	Dientes	142	Contrapeso	No	Diám Ext.	11.91"	OEM	12575076	V6 3.4L, 3.6L Chevrolet Equinox, Pontiac Torrent (05-09)			<table border="1"> <tr><td>Dientes</td><td>135</td></tr> <tr><td>Contrapeso</td><td>No</td></tr> <tr><td>Diám Ext.</td><td>11.32"</td></tr> <tr><td>OEM</td><td>12647333 / 12593689</td></tr> <tr><td colspan="2">L4 2.4L Captiva Sport (13-15), Equinox (10-15), Malibu (06-14), HHR (05-10) GMC Terrain (14-15) Cavalier L4 2.2L (02-05)</td></tr> </table>	Dientes	135	Contrapeso	No	Diám Ext.	11.32"	OEM	12647333 / 12593689	L4 2.4L Captiva Sport (13-15), Equinox (10-15), Malibu (06-14), HHR (05-10) GMC Terrain (14-15) Cavalier L4 2.2L (02-05)	
Dientes	142																						
Contrapeso	No																						
Diám Ext.	11.91"																						
OEM	12575076																						
V6 3.4L, 3.6L Chevrolet Equinox, Pontiac Torrent (05-09)																							
Dientes	135																						
Contrapeso	No																						
Diám Ext.	11.32"																						
OEM	12647333 / 12593689																						
L4 2.4L Captiva Sport (13-15), Equinox (10-15), Malibu (06-14), HHR (05-10) GMC Terrain (14-15) Cavalier L4 2.2L (02-05)																							
	<table border="1"> <tr><td>Dientes</td><td>142</td></tr> <tr><td>Contrapeso</td><td>No</td></tr> <tr><td>Diám Ext.</td><td>11.91"</td></tr> <tr><td>OEM</td><td>12572042</td></tr> <tr><td colspan="2">Buick LaCrosse (05-08), Buick Rendezvous (04-06), Cadillac CTS, SRX, STS (04-09), Pontiac G8 (08-09)</td></tr> </table>	Dientes	142	Contrapeso	No	Diám Ext.	11.91"	OEM	12572042	Buick LaCrosse (05-08), Buick Rendezvous (04-06), Cadillac CTS, SRX, STS (04-09), Pontiac G8 (08-09)			<table border="1"> <tr><td>Dientes</td><td>142</td></tr> <tr><td>Contrapeso</td><td>Si</td></tr> <tr><td>Diám Ext.</td><td>11.91"</td></tr> <tr><td>OEM</td><td>24506808</td></tr> <tr><td colspan="2">Chevrolet Camaro V6 3.8L (95-02), Pontiac Firebird V6 3.8L (95-02)</td></tr> </table>	Dientes	142	Contrapeso	Si	Diám Ext.	11.91"	OEM	24506808	Chevrolet Camaro V6 3.8L (95-02), Pontiac Firebird V6 3.8L (95-02)	
Dientes	142																						
Contrapeso	No																						
Diám Ext.	11.91"																						
OEM	12572042																						
Buick LaCrosse (05-08), Buick Rendezvous (04-06), Cadillac CTS, SRX, STS (04-09), Pontiac G8 (08-09)																							
Dientes	142																						
Contrapeso	Si																						
Diám Ext.	11.91"																						
OEM	24506808																						
Chevrolet Camaro V6 3.8L (95-02), Pontiac Firebird V6 3.8L (95-02)																							
	<table border="1"> <tr><td>Dientes</td><td>142</td></tr> <tr><td>Contrapeso</td><td>No</td></tr> <tr><td>Diám Ext.</td><td>11.91"</td></tr> <tr><td>OEM</td><td>12572042</td></tr> <tr><td colspan="2">Chevrolet Equinox (15-17), Traverse (16-17), Impala (16-17), Enclave (15-17), Cadillac SRX, XTS (15-17)</td></tr> </table>	Dientes	142	Contrapeso	No	Diám Ext.	11.91"	OEM	12572042	Chevrolet Equinox (15-17), Traverse (16-17), Impala (16-17), Enclave (15-17), Cadillac SRX, XTS (15-17)			<table border="1"> <tr><td>Dientes</td><td>142</td></tr> <tr><td>Contrapeso</td><td>No</td></tr> <tr><td>Diám Ext.</td><td>11.91"</td></tr> <tr><td>OEM</td><td>12553433</td></tr> <tr><td colspan="2">Oldsmobile Intrigue V6 3.5L (99-02), Oldsmobile Aurora V6 3.5L (01-02)</td></tr> </table>	Dientes	142	Contrapeso	No	Diám Ext.	11.91"	OEM	12553433	Oldsmobile Intrigue V6 3.5L (99-02), Oldsmobile Aurora V6 3.5L (01-02)	
Dientes	142																						
Contrapeso	No																						
Diám Ext.	11.91"																						
OEM	12572042																						
Chevrolet Equinox (15-17), Traverse (16-17), Impala (16-17), Enclave (15-17), Cadillac SRX, XTS (15-17)																							
Dientes	142																						
Contrapeso	No																						
Diám Ext.	11.91"																						
OEM	12553433																						
Oldsmobile Intrigue V6 3.5L (99-02), Oldsmobile Aurora V6 3.5L (01-02)																							
	<table border="1"> <tr><td>Dientes</td><td>161</td></tr> <tr><td>Contrapeso</td><td>No</td></tr> <tr><td>Diám Ext.</td><td>13.56"</td></tr> <tr><td>OEM</td><td>24100345</td></tr> <tr><td colspan="2">Chevrolet Colorado, GMC Canyon L4 2.8L (04-06), L4 2.9L (07-12), L5 3.5L (04-06), L5 3.7L (07-12), V8 5.3L (11-12)</td></tr> </table>	Dientes	161	Contrapeso	No	Diám Ext.	13.56"	OEM	24100345	Chevrolet Colorado, GMC Canyon L4 2.8L (04-06), L4 2.9L (07-12), L5 3.5L (04-06), L5 3.7L (07-12), V8 5.3L (11-12)			<table border="1"> <tr><td>Dientes</td><td>168</td></tr> <tr><td>Contrapeso</td><td>No</td></tr> <tr><td>Diám Ext.</td><td>14.13"</td></tr> <tr><td>OEM</td><td>12654640</td></tr> <tr><td colspan="2">Chevrolet Camaro V8 6.2L (11-15), Caprice V8 6.0L (12-16), Cheyenne, Silverado V8 4.8L, 5.3L, 6.0L, 6.2L (14-18), Suburban V8 5.3L, 6.2L (08-18), con transmisión 6L80</td></tr> </table>	Dientes	168	Contrapeso	No	Diám Ext.	14.13"	OEM	12654640	Chevrolet Camaro V8 6.2L (11-15), Caprice V8 6.0L (12-16), Cheyenne, Silverado V8 4.8L, 5.3L, 6.0L, 6.2L (14-18), Suburban V8 5.3L, 6.2L (08-18), con transmisión 6L80	
Dientes	161																						
Contrapeso	No																						
Diám Ext.	13.56"																						
OEM	24100345																						
Chevrolet Colorado, GMC Canyon L4 2.8L (04-06), L4 2.9L (07-12), L5 3.5L (04-06), L5 3.7L (07-12), V8 5.3L (11-12)																							
Dientes	168																						
Contrapeso	No																						
Diám Ext.	14.13"																						
OEM	12654640																						
Chevrolet Camaro V8 6.2L (11-15), Caprice V8 6.0L (12-16), Cheyenne, Silverado V8 4.8L, 5.3L, 6.0L, 6.2L (14-18), Suburban V8 5.3L, 6.2L (08-18), con transmisión 6L80																							
	<table border="1"> <tr><td>Dientes</td><td>105</td></tr> <tr><td>Contrapeso</td><td>No</td></tr> <tr><td>Diám Ext.</td><td>10.66"</td></tr> <tr><td>OEM</td><td>96058097</td></tr> <tr><td colspan="2">Geo Tracker 1.6L (89-98), transmisión TH-180 OEM # 96058097</td></tr> </table>	Dientes	105	Contrapeso	No	Diám Ext.	10.66"	OEM	96058097	Geo Tracker 1.6L (89-98), transmisión TH-180 OEM # 96058097			<table border="1"> <tr><td>Dientes</td><td>105</td></tr> <tr><td>Contrapeso</td><td>No</td></tr> <tr><td>Diám Ext.</td><td>10.66"</td></tr> <tr><td>OEM</td><td>91174526</td></tr> <tr><td colspan="2">Geo Tracker 2.0L (99-04) transmisión A40 OEM # 91174526</td></tr> </table>	Dientes	105	Contrapeso	No	Diám Ext.	10.66"	OEM	91174526	Geo Tracker 2.0L (99-04) transmisión A40 OEM # 91174526	
Dientes	105																						
Contrapeso	No																						
Diám Ext.	10.66"																						
OEM	96058097																						
Geo Tracker 1.6L (89-98), transmisión TH-180 OEM # 96058097																							
Dientes	105																						
Contrapeso	No																						
Diám Ext.	10.66"																						
OEM	91174526																						
Geo Tracker 2.0L (99-04) transmisión A40 OEM # 91174526																							



1.1 Aros dentados transmisión automática

Automatic transmission flex plates





General Motors

	AA-G201	Dientes	142
		Contrapeso	No
		Diám Ext.	11.98"
		OEM	12689004
	Chevrolet Camaro V6 3.6L (13-16), Colorado V6 3.6L (13-17), GMC Canyon V6 3.6L (13-17)		

	AA-G202	Dientes	168
		Contrapeso	No
		Diám Ext.	14.13"
		OEM	12620099
	Chevrolet Silverado V6 4.3L, V8 5.3L (14-19), Cheyenne, Suburban, Tahoe, GMC Sierra V8 5.3L, 6.2L (11-18) (8 tornillos al centro) OEM # 12620099		

Honda

	AA-H900	Dientes	N / A
		Contrapeso	No
		Diám Ext.	11.80"
		OEM	26251-P8F-000
	V6 3.0L, 3.5L Odyssey (05-06), Accord (06-07)		

	AA-H901	Dientes	N / A
		Contrapeso	No
		Diám Ext.	11.27"
		OEM	26251-PNA-000
	L4 2.4L Accord, CR-V (11-13), Element (02-11)		

	AA-H902	Dientes	N/A
		Contrapeso	No
		Diám Ext.	12.58"
		OEM	26251-RDJ-000
	Honda Accord (08-12), Odyssey (07-13), Pilot (11-15), transmisión 5AT		

Kia

	AA-K800	Dientes	112
		Contrapeso	No
		Diám Ext.	11.38"
		OEM	0K32B19020
	L4 1.5L, 1.6L Kia Rio (01-05)		

	AA-K801	Dientes	112
		Contrapeso	No
		Diám Ext.	11.38"
		OEM	0K25R19020A
	L4 1.8L Kia Spectra (00-03), Kia Sephia (98-01)		

1.1 Aros dentados transmisión automática

Automatic transmission flex plates



Kia

 <p>AA-K802</p>	Dientes	120
	Contrapeso	No
	Diám Ext.	12.06"
	OEM	23210-36500
	V6 3.5L Kia Sorento (03-04)	

Mitsubishi

 <p>AA-M700</p>	Dientes	N / A
	Contrapeso	N / A
	Diám Ext.	N / A
	OEM	MD707923
	L4 1.5L Mirage, Vista, Colt (89-96) (5 agujeros al centro)	

 <p>AA-M701</p>	Dientes	N / A
	Contrapeso	N / A
	Diám Ext.	N / A
	OEM	MD707924
	L4 1.8L, 2.0L Cordia, Eclipse, Galant (83-94) (6 agujeros al centro)	

 <p>AA-M702</p>	Dientes	N / A
	Contrapeso	N / A
	Diám Ext.	9.375"
	OEM	N / D
	L4 2.0L, 2.4L Eclipse, Expo, Galant (93-99) (7 agujeros al centro)	

 <p>AA-M703</p>	Dientes	N / A
	Contrapeso	N / A
	Diám Ext.	9.625"
	OEM	MD758464
	L4 1.5L Mitsubishi Mirage (97-02)	

Nissan

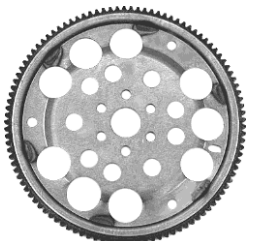
 <p>AA-N501</p>	Dientes	105
	Contrapeso	No
	Diám Ext.	10.735"
	OEM	12331-12M20
	L4 1.5L, 1.6L Tsuru I y II (84-92)	

 <p>AA-N502</p>	Dientes	105
	Contrapeso	No
	Diám Ext.	10.735"
	OEM	12331-75Y10
	L4 1.6L Tsuru III (8 válvulas) (93-95)	

1.1 Aros dentados transmisión automática

Automatic transmission flex plates





Nissan

	Dientes	105
	Contrapeso	No
	Diám Ext.	10.735"
	OEM	12331-78A10
L4 1.6L Tsuru III (16 válvulas) (93-16)		

	Dientes	120
	Contrapeso	No
	Diám Ext.	12.05"
	OEM	12331-U9511
L4 2.2L Pick up 720 (81-82), 280Z L6 2.8L (75-78), 280ZX L6 2.8L (79-83)		

	Dientes	120
	Contrapeso	No
	Diám Ext.	12.05"
	OEM	12303-N9511
L4 1600, 1800 Datsun automovil (74-83)		

	Dientes	120
	Contrapeso	No
	Diám Ext.	12.05"
	OEM	12331-24G02
L4 2.0L, 2.2L, 2.4L Datsun autos y pick ups motores Z20, Z22 y Z24 (80-89)		

	Dientes	105
	Contrapeso	No
	Diám Ext.	10.735"
	OEM	12312-01M01
L4 1488cc (1.5L), 1597cc (1.6L) Nissan 310 (1982), Pulsar NX (83-88) (U.S.A.) (transmision RN / RL3F01A)		

	Dientes	120
	Contrapeso	No
	Diám Ext.	12.05"
	OEM	12331-17C00
L4 2.4L (KA24E) Pick Up D21, SE, XE, 2.4L KA24E (91-98)		

	Dientes	120
	Contrapeso	No
	Diám Ext.	12.05"
	OEM	12331-16E11
V6 3.0L Maxima (85-94)		

	Dientes	122
	Contrapeso	No
	Diám Ext.	10.14"
	OEM	37537-1800R
Nissan Platina 1.6L K4M (02-11)		

	Dientes	120
	Contrapeso	No
	Diám Ext.	12.05"
	OEM	12331-2B600
Nissan Altima 2.4L (93-01), XTerra 2.4L (02-04) OEM # 12331-2B600		





1.1 Aros dentados transmisión automática

Automatic transmission flex plates





Toyota

AA-T600 	Dientes	115
	Contrapeso	No
	Diám Ext.	11.60"
	OEM	32101-20050
	L4 2189cc (2.2L), 2366cc (2.4L) Pick ups Toyota (75-95), 4Runner (84-95), Celica (75-85), motores 20R, 22R, 22RE (6 tornillos cigüeñal)	

AA-T601 	Dientes	115
	Contrapeso	No
	Diám Ext.	11.60"
	OEM	32101-26010
	L4 2.4L, 2.7L Tacoma (95-12), T-100 (95-98), 4Runner (96-00) (10 tornillos cigüeñal)	

AA-T602 	Dientes	106
	Contrapeso	No
	Diám Ext.	10.66"
	OEM	32101-12060
	L4 1.6L, 1.8L Celica (96-97), Corolla (83-97) (6 tornillos cigüeñal)	

AA-T603 	Dientes	120
	Contrapeso	No
	Diám Ext.	11.95"
	OEM	32101-32051
	L4 2.0L, 2.2L Camry (90-01), Celica (90-99), MR2 (91-95), Solara (99-01) (8 tornillos cigüeñal)	

AA-T604 	Dientes	120
	Contrapeso	No
	Diám Ext.	11.95"
	OEM	32101-35010
	V6 3.0L, 3.4L 4Runner (88-02), Tacoma (95-04), T-100 (93-98), Tundra (00-04), Pick ups Toyota (89-95) (8 tornillos cigüeñal)	

AA-T605 	Dientes	106
	Contrapeso	No
	Diám Ext.	10.67"
	OEM	32101-12091
	Corolla 1.8L (98-08), Matrix 1.8L (03-08), Celica 1.8L (00-05), Chevrolet Prizm (98- 02), Pontiac Vibe 1.8L (03-08)	

Volkswagen

AA-VW600 	Dientes	132
	Contrapeso	No
	Diám Ext.	11.12"
	OEM	053105323E
	L4 1588cc (1.6L), 1715cc (1.7L), 1780cc (1.8L) Caribe, Golf, Jetta (76-92)	



1.2 Aros dentados transmisión estándar

Flywheel ring gear



NO LODI	NO ORIGINAL	MOTORES
---------	-------------	---------

American Motors / Jeep

AS-153R	3172419	123, 199, 258 (65-72)
AS-164A	3179741	232, 258, 282, 304, 360, 401 Transmisión MT (72-88)

Chrysler / Dodge

AS-090A	23212-02510	Atos 1.0L, 1.1L (00-adelante)
AS-122T	2121196 / 2863495	170, 225, 272, 273, 318, 360, 426 (62-89)
AS-130C	3515203	Plymouth L6 y V8 (74-89)
AS-130T	1941648 / 2863497	272, 318, 383, 426, 440 (62-87)
AS-139A	5222789	135 (2.2L) Serie K
AS-139 CH	4348276	135 (2.2L) y 156 (2.6L) Serie K
AS-139CF	838177	135 (2.2L) y 156 (2.6L) Serie K (aro delgado)
AS-143N	2843214	225, 318, 360, 383, 440 Embrague 11" o 12" (68-89), Pick up Ram V6 3.9L, V8 5.2L, 5.9L (94-02)
AS-146XF	1138903 / 1119963 / 8057373439	C6, C13, C22, C24, C25, C28, C34, C164 (Camionetas)
AS-148T	2121195 / 2863496	170, 225 (Dodge y Plymouth) 148NC
AS-158A	3732638	Dodge 225, 318, 360, (74-77) Pickups
AS-172S	2863494	225, 273, 318, 326, 361, 383, 392, 413 (60-77)
AS-186T	1733880	318, 360, 361, 383, 413 CID Embrague 13" (Camionetas)

Cummins

AS-103T	6771283 / 4797	L6 250, 400
AS-127D	3905427	Dina V6 y V8 140, 155, 185, 210

Ford

AS-112NR	8BA-6384 A	239 (48-53)
AS-132E	D4FZ-6384 A	98, 116, 140, 153, 182 (Taurus y Topaz), Ranger 2.3L
AS-132F	C0DP-6384 A	144, 170, 200, 223 Turbina de transmisión automática
AS-134XR	9 N 6384	Tractor 4 cil. (39-88)
AS-135A	D1FZ-6384-A	Pinto 1.6 L, 2.0 L (71-74)
AS-138RY	D2RY-6384-A	Bronco, Ranger 2.8L, 2.9L (83-96)
AS-146SR	EAA-6384-A	223, 272, 292, 293, 312 (52-67)
AS-148S	PMB-6384-A / B8A-6375 D	Ford 292 (58-62)
AS-155FT	E5TZ-6384 B	239, 272, 292, 312 Transmisión automática
AS-157N	C2OZ-6384-A / C7OP-6384-A	170, 200, 221, 230, 250, 289, 302 (62-89)
AS-160T		Falcon 170, 188, 221, 250
AS-164N	C5AZ-6384-D	289, 302, 351 (65-96), 4.6L, 5.4L (97-10)
AS-168R	Z5AZ-6384-A	286, 302, 351 (65-70 y 83-84)
AS-180W	D7TZ-6384-A	F600, 335, 351, 370, 400, 429, 460 (77-89)
AS-184T	C5AZ-6384-A	327, 390, 410 (65-78)
AS-188T	C4TZ-6384-A	330, 359, 361, 389, 391 (Camionetas 64-78)

1.2 Aros dentados transmisión estándar

Flywheel ring gear



NO LODI	NO ORIGINAL	MOTORES
---------	-------------	---------

General Motors

AS-135GM		Chevy, Monza, Joy y Swing
AS-139G	14077156	216 6 Cil. (40-54)
AS-142W	359115	173 6 Cil. Celebrity y Citation
AS-148B	14033090	L4 121 (2.0L) y V6 173 (2.8L) 82-89
AS-153N	3789821	C10, C20, 250, 307, 350, 370, 396
AS-168S	460583 / 3991408	250, 283, 292, 307, 350 (69-03), 4.3L, 4.8L, 5.3L (04-10)
AS-191T	2369440	V6 305, 351, 379, 401 (60-76)
AS-197B	3991409	366, 348, 350 (5.7L), 366, 386, 427 (58-88)
AS-197N	3737920	V8 327, 350, 366, 409, 427 (62-78)
AS-204A	14001923	V8 427, 454 (79-89)

Honda

AS-103H		Prelude (88-84)
AS-107S		Legend (86-89)
AS-114A		

Hyundai

AS-110MI	MD040556	Hyundai H-100 2.4L Gasolina
----------	----------	-----------------------------

John Deere

AS-129F	R28811	
---------	--------	--

Mercedes Benz

AS-140Z	615032, 0105	
---------	--------------	--

Mitsubishi

AS-106M	MD030629	Eclipse (92-99), Eagle Talon (92-99)
AS-110MI	MD040556	Autos y pick ups motores 4G32, 4G37, 4G63, 6G72 (83-04)

Navistar

AS-138L	1815440C1	Navistar e International
---------	-----------	--------------------------

1.2 Aros dentados transmisión estándar Flywheel ring gear



NO LODI	NO ORIGINAL	MOTORES
----------------	--------------------	----------------

Nissan / Datsun

AS-105	12312-61A00	Tsuru I, II y III (84-94)
AS-105A	12312-F4100	Tsuru III 16 válvulas GA16DE (95-10)
AS-105G	12312-18000	Datsun 68-84
AS-108T	12312-01M10	Tsuru 1500
AS-115N	12312-09600	1500, 1600
AS-119C	8200279345	Nissan Platina, Renault Clio L4 1.6L (02-11)
AS-120C	12312-6100	1800, 1952, 2187, 2393, 2753
AS-146Z	12312-58000	Z20, Z22 y Z24, 2.0L, 2.2L, 2.4L (81-90)

Perkins

AS-126F	B4010236	354 6 Cil. (60-75)
---------	----------	--------------------

Toyota

AS-106C	13453-10010	L4 1077cc 1166cc, 1290cc (68-86)
AS-115C	13453-20010	4 y 6 cil. (68-85)
AS-136C	13453-60010	6 cil. 4230cc (74-86)

Volkswagen

AS-125C	055 105 275	Caribe 1700 4 cil.
AS-130VW	043 105 275	Sedán 1600
AS-132P	056 105 275C	Pointer, autos y pick ups (97-07)
AS-132VW	068 105 275A	Golf, Jetta, New Beetle (92 en adelante)

1.3 Aros dentados transmisión estándar dimensiones Flywheel ring gear dimensions

Número LODI	Marca	Diámetro exterior	Diámetro interior	Espesor	No. de dientes	Chaflán	Paso
AS-090A	CHRYSLER / HYUNDAI	9.060"	8.340"	0.355"	90	REVERSO	
AS-103T	CUMMINS	17.385"	15.996"	0.871"	103	FRENTE	6/8
AS-103H	HONDA	10.625"	10.450"	0.355"	103	FRENTE	
AS-105G	NISSAN	10.725"	9.425"	0.390"	105	REVERSO	10/12S
AS-105	NISSAN	10.725"	9.425"	0.390"	105	FRENTE	10/12S
AS-105A	NISSAN	10.740"	9.695"	0.399"	105	FRENTE	
AS-106C	TOYOTA	10.670"	9.520"	0.318"	106	FRENTE	
AS-106M	MITSUBISHI	10.669"	9.665"	0.331"	106	FRENTE	
AS-107S	HONDA	10.766"	9.603"	0.354"	107	FRENTE	10
AS-108T	NISSAN	10.740"	9.460"	0.321"	108	FRENTE	8/10
AS-110MI	MITSUBISHI	11.095"	10.400"	0.388"	110	REVERSO	
AS-112NR	FORD	14.180"	12.868"	0.370"	112	REVERSO	8/10
AS-114A	HONDA	11.540"	10.030"	0.381"	114	FRENTE	10/12
AS-115N	NISSAN	11.620"	10.340"	0.475"	115	FRENTE	10
AS-115C	TOYOTA	11.600"	10.200"	0.361"	115	FRENTE	
AS-119C	NISSAN / RENAULT	10.125"	9.240"	0.320"	119	SIN	
AS-120C	NISSAN	12.051"	10.780"	0.475"	120	FRENTE	10

1.3 Aros dentados transmisión estándar dimensiones

Flywheel ring gear dimensions



Número LODI	Marca	Diámetro exterior	Diámetro interior	Espesor	No. de dientes	Chaflán	Paso
AS-122T	CHRYSLER	12.276"	11.190"	0.350"	122	SIN	10
AS-125C	VW	10.588"	9.856"	0.325"	125	SIN	11.85
AS-126F	PERKINS	15.930"	14.819"	0.702"	126	SIN	8/10
AS-127D	CUMMINS	16.050"	14.998"	0.735"	127	FRENTE	8/10
AS-129F	JOHN DEERE	16.353"	15.171"	0.562"	129	FRENTE	8/10
AS-130T	CHRYSLER	13.195"	12.160"	0.375"	130	SIN	10
AS-130VW	VW	10.878"	9.993"	0.375"	130	SIN	12
AS-130C	CHRYSLER	10.878"	9.993"	0.375"	130	SIN	12
AS-132E	FORD	11.256"	10.141"	0.365"	132	SIN	12.025
AS-132F	FORD	11.157"	10.309"	0.365"	132	SIN	12/14
AS-132VW	VW	11.050"	10.150"	0.412"	132	SIN	
AS-132P	VW	11.060"	10.040"	0.318"	132	SIN	
AS-134XR	FORD	13.530"	12.000"	0.364"	134	REVERSO	
AS-135A	FORD	11.293"	10.402"	0.365"	135	SIN	12
AS-135GM	GENERAL MOTORS	11.350"	10.260"	0.353"	135	SIN	
AS-136C	TOYOTA	13.740"	12.525"	0.510"	136	FRENTE	10/12
AS-138RY	FORD	11.642"	10.475"	0.373"	138	SIN	12
AS-138L	INTERNATIONAL / NAVISTAR	17.430"	16.250"	0.640"	138	FRENTE	
AS-139A	CHRYSLER	11.767"	10.823"	0.331"	139	SIN	12
AS-139CF	GENERAL MOTORS	14.015"	13.060"	0.500"	139	FRENTE	10/12
AS-139CH	CHRYSLER	14.130"	13.271"	0.5"	139	FRENTE	10
AS-139G	GENERAL MOTORS	14.130"	13.271"	0.455"	139	FRENTE	
AS-140Z	MERCEDES	11.794"	10.553"	0.468"	140	FRENTE	12
AS-142W	GENERAL MOTORS	11.910"	11.088"	0.453"	142	SIN	12
AS-143N	CHRYSLER	14.568"	13.560"	0.340"	143	SIN	10
AS-146SR	FORD	14.774"	13.352"	0.365"	146	SIN	10
AS-146XF	CHRYSLER	14.640"	13.560"	0.375"	146	FRENTE	10
AS-146Z	NISSAN	14.713"	13.645"	0.560"	146	FRENTE	10
AS-148A	GENERAL MOTORS	12.397"	11.400"	0.375"	148	SIN	
AS-148S	FORD	15.007"	14.013"	0.370"	148	SIN	10/12
AS-148T	CHRYSLER	12.520"	11.189"	0.370"	148	SIN	12
AS-148B	GENERAL MOTORS	12.410"	11.588"	0.453"	148	SIN	12
AS-153N	GM	12.835"	12.003"	0.440"	153	SIN	12/14
AS-153R	AMC	12.825"	11.793"	0.440"	153	SIN	12/14
AS-155FT	FORD	15.700"	14.435"	0.501"	155	FRENTE	
AS-157N	FORD	13.294"	12.025"	0.365"	157	SIN	12/14
AS-158A	CHRYSLER	15.865"	14.650"	0.355"	158	SIN	
AS-160T	FORD	13.250"	12.000"	0.363"	160	SIN	
AS-164A	AMC	13.830"	12.820"	0.420"	164	SIN	12/14
AS-164N	FORD	14.215"	12.955"	0.375"	164	SIN	12 ESP
AS-168R	FORD	14.190"	13.232"	0.440"	168	SIN	12 ESP
AS-168S	GENERAL MOTORS	14.096"	13.268"	0.440"	168	SIN	12//14
AS-172S	CHRYSLER	14.640"	13.561"	0.35"	172	SIN	12
AS-180W	FORD	15.512"	14.518"	0.440"	180	SIN	12
AS-184T	FORD	15.512"	14.210"	0.375"	184	SIN	12/14
AS-186T	CHRYSLER	15.503"	14.691"	0.375"	186	SIN	12
AS-188T	FORD	15.869"	14.728"	0.375"	188	SIN	12
AS-191T	GENERAL MOTORS	16.102"	15.012"	0.485"	191	SIN	12/14
AS-197B	GENERAL MOTORS	15.970"	15.682"	0.453"	197	SIN	12/14 M
AS-197N	GENERAL MOTORS	16.522"	15.670"	0.437"	197	SIN	12
AS-204A	GENERAL MOTORS	17.107"	16.267"	0.453"	204	SIN	12/14



Filtro y empaque de transmisión automática

Existen diferentes tipos de filtros para transmisión automática, la diferencia entre estos radica en el tipo de material usado como elemento filtrante, los cuales son:

Filtro o felpa

El filtro de fieltro o felpa tiene como principal característica, un alto nivel de filtración y un excelente flujo de fluido. Las fibras del filtro, están impregnadas de resina fenólica, añadiéndole la fuerza y capacidad de soportar la temperatura del fluido al más alto nivel del rango de operación de la transmisión. Filtra partículas de hasta aproximadamente 60 micras.

Latón

Elemento filtrante elaborado a base de malla de latón. Fuerte y duradero. La capacidad de filtración varía en función del tamaño de la malla; puede variar de 117 a 205 micras.

Acero

Elemento filtrante elaborado a base de malla de acero. Fuerte y duradero. La capacidad de filtración varía en función del tamaño de la malla, que puede ser de 75 a 190 micras.

Plástico/Nylon

El elemento filtrante es a base de una malla de nylon. Filtra partículas de hasta aproximadamente 130 micras.

Papel

Esta impregnado con resina fenólica, lo cual le adhiere fuerza y la capacidad de soportar altas temperaturas del fluido. Filtra partículas de hasta aproximadamente 30 a 40 micras.

Filtro sellado (Elemento de papel)

Soporta altas temperaturas del fluido. Filtra partículas de hasta aproximadamente 30 a 40 micras.

Filtro magnético

Cuenta con un poderoso imán capaz de atraer los contaminantes ferrosos. Diseñado para proporcionar una eficaz filtración mientras se mantiene el flujo adecuado de fluidos. El elemento de papel filtra las partículas de metales no ferrosos. Filtra partículas de hasta aproximadamente 25 micras.

Empaque o junta de corcho

Combinación balanceada de corcho 100% virgen y nitrilo. Resistente a las altas temperaturas del aceite. Proporciona la compresibilidad exacta para un perfecto sellado.

Empaque o junta de corcho ahulado

Combinación de hule sintético y de corcho. Gran resistencia a las temperaturas elevadas del aceite. Gracias a sus cualidades de compresibilidad y capacidad de recuperación, garantizan un óptimo sellado.

Procedimiento de instalación:

- 1) Coloque una charola o recipiente justo debajo del cárter de la transmisión.
- 2) Retire los tornillos de un lado del cárter y empiece a aflojar los del lado contrario. Con esta acción, el cárter se inclinara, lo que permitirá que el aceite comience a drenar.
- 3) Ya que se haya drenado la mayor parte del aceite, retire el resto de los tornillos junto con el cárter. Vacíe el aceite restante en la charola o recipiente.
- 4) Retire los restos de empaque del cárter y de la superficie de la transmisión. Si el cárter cuenta con un imán, retírelo, límpielo y vuélvalo a instalar.
- 5) Retire el filtro usado, y de ser necesario, compárelo con el nuevo. A continuación, instale el filtro nuevo.
- 6) Presente y coloque el empaque nuevo en el cárter. Coloque algunos tornillos en el cárter, a distancia unos de otros, esto permitirá que el empaque permanezca en su lugar al momento de la instalación. Procure no utilizar ningún tipo de sellador. Continúe con la instalación del cárter, apoyándose con los tornillos instalados previamente en el mismo y luego con el resto de los demás.
- 7) Apriete los tornillos de manera alternada hasta que todos queden ajustados. Procure no apretarlos de mas (10 a 12 lbs/pie son suficientes). Si son apretados de más, existe el riesgo de que el empaque sufra daño y tenga como consecuencia, que se presenten fugas de fluido.
- 8) Agregue la cantidad de aceite nuevo indicada por el fabricante. No lo llene de más.
- 9) Con el motor encendido y en marcha mínima, con la transmisión en parking (P) o en neutral (N), revise el nivel de aceite de la transmisión. Inspeccione debajo del vehículo para descartar alguna fuga.
- 10) Circule en el vehículo para probar que el desempeño sea el apropiado y enseguida repita el paso anterior.

Advertencia: El aceite de transmisión automática alcanza temperaturas extremas. Déjelo enfriar antes de drenarlo.



Pide que sea 

- ✓ **Calidad de equipo original**
- ✓ **Amplia cobertura de aplicaciones**
- ✓ **Productos 100% garantizados**
- ✓ **Altamente confiables**

**¿ALGUNA
DUDA?**

800 227 5634

1.4 Filtro y empaque de transmisión automática

Automatic transmission filter kits



American Motors

FC-BWT35

BW-T35

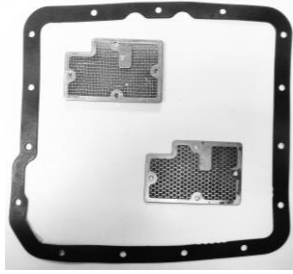

MODELO

AÑOS

American, Super Six, Gremlin, Hornet
(transmisión FLASH-O-MATIC)

62-66

MOTOR

L6, V8

TC 15 TRACC T OEM 3179973 3 VEL

FC-BWT65

BW-T35



MODELO

AÑOS

Custom, Deluxe, Super Six, Gremlin, Hornet,
Javelin, Marlin, Matador, Rebel
(transmisión FLASH-O-MATIC)

67-71

MOTOR

L6, V8

TC 15 TRACC T OEM 3188896 3 VEL

BMW

FC-5L40E

5L40E

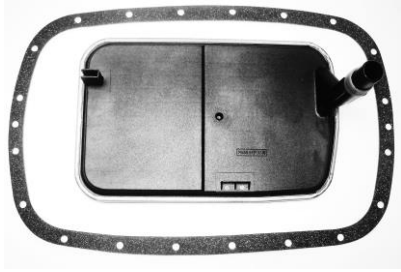

MODELO

AÑOS

325Ci, 330Ci, 525i, 528i, 530i

00-06

MOTOR

TODOS

TC 22 TRACC T OEM 24117-510-012 5 VEL

FC-5L40EA

5L40EA

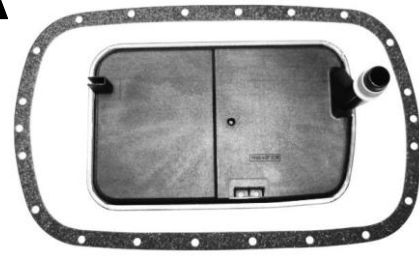

MODELO

AÑOS

X5, Z4

00-06

MOTOR

V6

TC 22 TRACC T OEM 24111-423-604 5 VEL

FC-5L40EB

5L40E/5L50E

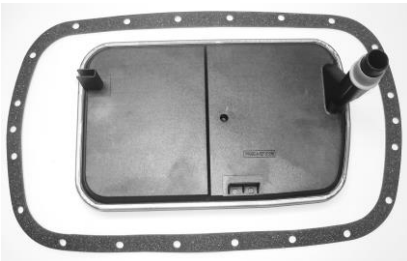

MODELO

AÑOS

318i, Cadillac CTS, SRX

00-09

MOTOR

L4, V6

TC 22 TRACC T OEM 2-4722-000 5 VEL

FC-6L45R

6L45R

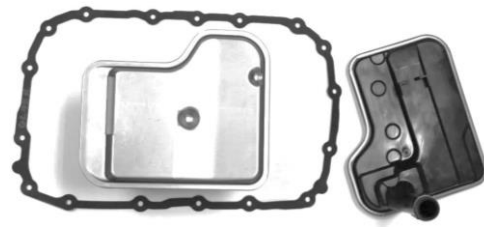

MODELO

AÑOS

BMW X3
328i, 328Xi

06-08

MOTOR

L6

TC 17 TRACC T OEM 24117-593-565 6 VEL

1.4 Filtro y empaque de transmisión automática

Automatic transmission filter kits



BMW

FC-BWT66
BW-T66



MODELO						AÑOS	
3.0CS, 3.0S, 3.0SI, Bavaria						72-76	
						MOTOR	
TC	12	TRACC	T	OEM	4277455	3	VEL

FC-ZF3HP22
ZF3HP22



MODELO						AÑOS	
3.0SI, 318i, 318ic,318is,318ti,320i						76-84	
						MOTOR	
TC	N/R	TRACC	T	OEM	24231-209-747	3	VEL

FC-ZF4HP22
ZF4HP22, ZF4HP24

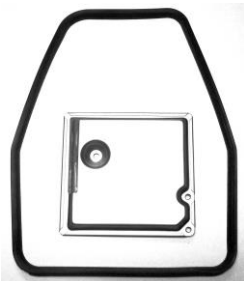

MODELO						AÑOS	
325, 325e						84-91	
						MOTOR	
TC	NR	TRACC	T	OEM	E4LY-7A098-A	4	VEL

FC-ZF5HP18
ZF5HP18



MODELO						AÑOS	
530i, M3						93-96	
						MOTOR	
TC	N/R	TRACC	T	OEM	24341-219-631	5	VEL

FC-ZF5HP30
ZF5HP30



MODELO						AÑOS	
540i, 740i, 750Li,840ci,850						91-01	
						MOTOR	
TC	23	TRACC	T	OEM	24341-422-419	5	VEL

FC-ZF6HP19
ZF6HP19



MODELO						AÑOS	
BMW X5 3.0L BMW X6 3.0L BMW Z4 Roadster 3.0L						05-08	
						MOTOR	
TC	24	TRACC	T	OEM	24117-536-387	6	VEL

1.4 Filtro y empaque de transmisión automática

Automatic transmission filter kits



BMW

FC-ZF6HP26

ZF6HP26



MODELO

AÑOS

BMW X5 V8 4.4L, 4.8L , X6 V8 4.4L ,
6 Series V8 4.4L, 4.8L, 7 Series V8 4.4L,
V12 6.0L

04-08

MOTOR

V8, V12

TC	21	TRACC	T	OEM	24117-522-923	6	VEL
----	----	-------	---	-----	---------------	---	-----

Chrysler / Dodge / Jeep

FC-42RLE

42RLE

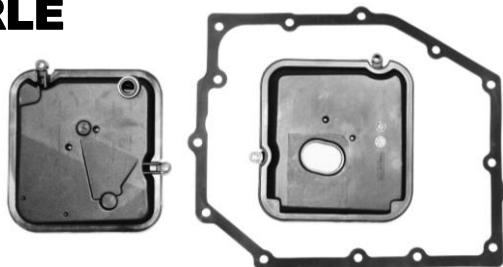

MODELO

AÑOS

Dakota, Durango, Nitro, Challenger,
300, Charger

03-09

MOTOR

L4 , V6

TC	13	TRACC	T	OEM	52852913AB	4	VEL
----	----	-------	---	-----	------------	---	-----

FC-42RLEA

42RLE

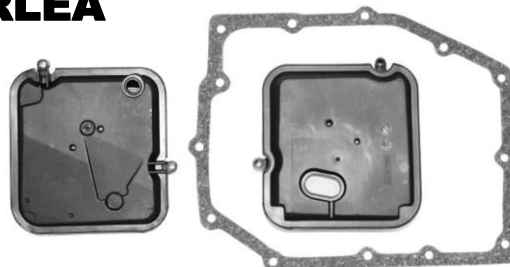

MODELO

AÑOS

Jeep Liberty,
Jeep Wrangler

03-12

MOTOR

L4 , V6

TC	13	TRACC	T	OEM	52852913AB	4	VEL
----	----	-------	---	-----	------------	---	-----

FC-44RE

42, 44, 46, 47 RE

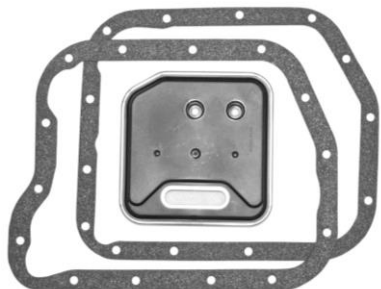

MODELO

AÑOS

Dakota, Durango,
Ram 1500, 2500, 3500

98-03

MOTOR

V6, V8, V10

TC	14	TRACC	T	OEM	52118789	4	VEL
----	----	-------	---	-----	----------	---	-----

FC-45RFE

45RFE, 55RFE



MODELO

AÑOS

Jeep Grand Cherokee 4x 2, Durango,
Ram 1500, 2500, 3500 (2WD)

99-11

MOTOR

V6,V8

TC	15	TRACC	D	OEM	4800029AA	4	VEL
----	----	-------	---	-----	-----------	---	-----

1.4 Filtro y empaque de transmisión automática

Automatic transmission filter kits



Chrysler / Dodge / Jeep

FC-45RFE4
45RFE, 55RFE



MODELO						AÑOS	
Jeep Grand Cherokee 4 x 4, Durango, Ram 1500, 2500, 3500 (4WD)						99-09	
						MOTOR	
TC	15	TRACC	D	OEM	4799507	4	VEL

FC-45RFECA
45RFE, 545RFE



MODELO						AÑOS	
Todos los modelos Chrysler, Dodge, Jeep con trans. 45RFE y 545RFE						99-11	
						MOTOR	
TC	NR	TRACC	T	OEM	4799662	4 y 5	VEL

FC-62TE
62TE



MODELO						AÑOS	
Avenger, Journey, Pacifica, Caravan, Town & Country, Voyager						07-10	
						MOTOR	
TC	12	TRACC	D/AWD	OEM	05078555AA	6	VEL

FC-6F24
6F24

NUEVO PRODUCTO



MODELO						AÑOS	
Jeep Patriot 2.0L, 2.4L Jeep Compass 2.4L Dodge Dart 2.0L, 2.4L						13-17	
						MOTOR	
TC	NR	TRACC	D	OEM	68192984AA	6	VEL

FC-948TE
948TE

NUEVO PRODUCTO



MODELO						AÑOS	
Jeep Cherokee 2.4L, V6 3.2L						14-17	
						MOTOR	
TC	NR	TRACC	D	OEM	4752814AA	9	VEL

FC-A404F
A-404 DACRON



MODELO						AÑOS	
Dart K, Volare K, Lebaron						78-82	
						MOTOR	
TC	14	TRACC	D	OEM	4207219	3	VEL

1.4 Filtro y empaque de transmisión automática

Automatic transmission filter kits



Chrysler / Dodge / Jeep

FC-A404M
A-404-413-470

MODELO					AÑOS		
Neón, Shadow, Spirit					87-02		
					MOTOR		
					L4, V6		
TC	14	TRACC	D	OEM	4207219	3	VEL

FC-A465
A465 / AS68RC

NUEVO PRODUCTO

MODELO					AÑOS		
Pick up Ram 3500, 4500 Heavy Duty, 6.7L diesel					07-12		
					MOTOR		
					L6		
TC	18	TRACC	T	OEM	68019688AA	6	VEL

FC-A4AF
A4B-F3

MODELO					AÑOS		
Verna by Dodge, Hyundai 1.6L y 1.8L					00-06		
					MOTOR		
					L4		
TC	13	TRACC	D	OEM	46321-22731	4	VEL

FC-A604
A-604

MODELO					AÑOS		
Spirit, Shadow, Caravan, Voyager, Grand Voyager, Stratus, PT Cruiser					89-09		
					MOTOR		
					L4, V6		
TC	14	TRACC	D	OEM	4504048	4	VEL

FC-A606
A-606, 42LE

MODELO					AÑOS		
Chrysler 300M, Concorde, Intrepid					93-04		
					MOTOR		
					V6		
TC	13	TRACC	D	OEM	4626449	4	VEL

FC-A727
A904, A727

MODELO					AÑOS		
Chrysler, Dodge, Plymouth (autos y pick ups) trans. A904 y A727 (small filter)					63-72		
					MOTOR		
					L6, V8		
TC	14	TRACC	T	OEM	3621456	3	VEL

1.4 Filtro y empaque de transmisión automática

Automatic transmission filter kits



Chrysler / Dodge / Jeep

FC-AS69RC
AS69RC

NUEVO PRODUCTO

MODELO				AÑOS			
Pick up Ram 2500, 3500, 4500, 5500 L6 6.7L diesel, V8 6.4L				13-17			
				MOTOR			
TC	20	TRACC	T	OEM	68224232AA	6	VEL

FC-A904
TF6/A904

MODELO				AÑOS			
Chrysler, Dodge, Plymouth con trans. TF6 "baby A904" (empaque de cárter corto),				74-92			
				MOTOR			
TC	14	TRACC	T	OEM	3515996	3	VEL

FC-AW4
AW4, AW30LE

MODELO				AÑOS			
Jeep Grand Cherokee, Wagoneer				87-01			
				MOTOR			
TC	19	TRACC	T	OEM	83504032	4	VEL

FC-CVTC
RE0F10A (CVT)

NUEVO PRODUCTO

MODELO				AÑOS			
Dodge Caliber; Jeep Compass; (filtro externo)				05-17			
				MOTOR			
TC	NR	TRACC	D	OEM	31726-1XF00	CVT	VEL

FC-JF011E
RE0F10A (CVT)

NUEVO PRODUCTO

MODELO				AÑOS			
Dodge Caliber ; Jeep Compass ; ,filtro con cuello alto (26.8mm)				07-16			
				MOTOR			
TC	20	TRACC	D	OEM	31728-1XZ0A	CVT	VEL

FC-KM170
KM170

MODELO				AÑOS			
Challenger, Colt, Champ				79-82			
				MOTOR			
TC	12	TRACC	D	OEM	MD707786	4	VEL

1.4 Filtro y empaque de transmisión automática

Automatic transmission filter kits



Chrysler / Dodge / Jeep

FC-KM177
KM171 / KM177

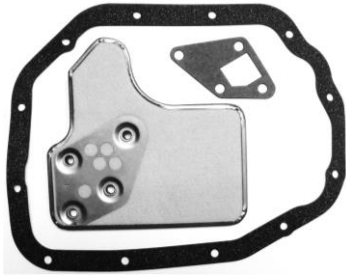

MODELO						AÑOS	
Dodge Colt, Colt Vista, Eagle 2000 GTX, Eagle Summit						87-94	
						MOTOR	
						L4	
TC	12	TRACC	D	OEM	MD729954	4	VEL

FC-TF6/8
T/F 727, 904

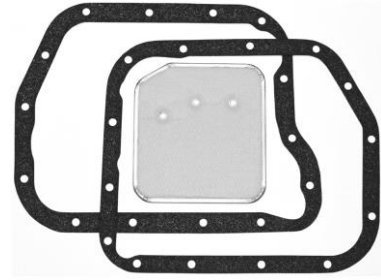

MODELO						AÑOS	
Chrysler, AMC						74-98	
						MOTOR	
						V6, V8	
TC	14	TRACC	T	OEM	3515996	3	VEL

FC-TF6CH
T/F 6-904

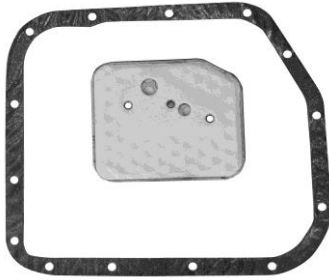

MODELO						AÑOS	
Chrysler, AMC						62-92	
						MOTOR	
						V6	
TC	14	TRACC	T	OEM	3621456	3	VEL

FC-TF6G
TF6-904

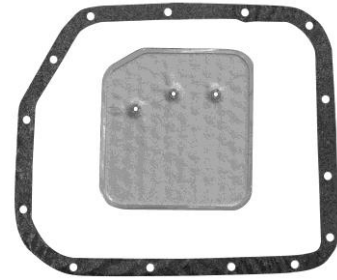

MODELO						AÑOS	
Chrysler, AMC						66-98	
						MOTOR	
						L6	
TC	14	TRACC	T	OEM	3515996	3	VEL

FC-TF8
T/F 8-727

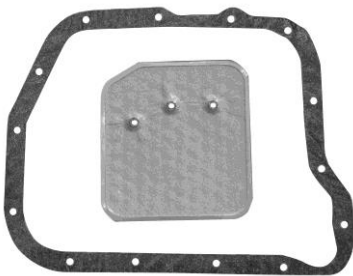

MODELO						AÑOS	
Chrysler, AMC						74-98	
						MOTOR	
						L6	
TC	14	TRACC	T	OEM	3410523	3	VEL

FC-TF8CH
TF8



MODELO						AÑOS	
Chrysler, Dodge, Plymouth (autos y pick ups) (62-66), (small filter)						62-66	
						MOTOR	
						L6, V8	
TC	14	TRACC	T	OEM	2466849	3	VEL

1.4 Filtro y empaque de transmisión automática

Automatic transmission filter kits



Chrysler / Dodge / Jeep

FC-W5A580
W5A580 / 722.6



MODELO		AÑOS					
Charger, SRT, Challenger, Nitro, Chrysler 300C, Magnum, Sprinter Van		05-09					
		MOTOR					
		V6, V8					
TC	6	TRACC	T	OEM	140-277-0095	5	VEL

FC-ZF4HP14
ZF4HP14



MODELO		AÑOS					
Dodge Monaco, Eagle Premier		88-92					
		MOTOR					
		V6					
TC	N/R	TRACC	D	OEM	1036-226-013	4	VEL

Ford

FC-4EAT
4EAT-F/ F4A-EL



MODELO		AÑOS					
Escort, Escort ZX2		91-03					
		MOTOR					
		L4					
TC	19	TRACC	D	OEM	FU61-21-500B	4	VEL

FC-4EATG
4EAT-G, G4A-HL
Filtro de 0.625" alto



MODELO		AÑOS					
Probe, Mazda 626 Turbo		88-92					
		MOTOR					
		L4, V6					
TC	17	TRACC	D	OEM	E92Z-7A098-A	4	VEL

FC-4EATGN
4EAT-G, GF4A-EL



MODELO		AÑOS					
Probe, Mazda 626		93-97					
		MOTOR					
		L4, V6					
TC	17	TRACC	D	OEM	F32Z-7A098-A	4	VEL

FC-4F27E
4F27E (J39A)



MODELO		AÑOS					
Focus, Mazda, Ecosport		00-08					
		MOTOR					
		L4					
TC	20	TRACC	D	OEM	XS4Z-7A098-AB	4	VEL

1.4 Filtro y empaque de transmisión automática

Automatic transmission filter kits



Ford

FC-318

DCT450



MODELO					AÑOS	
Focus L4 1.6L, 2.0L, L5 2.5L					08-12	
					MOTOR	
					L4, L5	
TC	N/R	TRACC	D	OEM	6	VEL

FC-319

HF35



MODELO					AÑOS	
Ford Fusion, Lincoln MKZ					13-17	
					MOTOR	
					L4	
TC	N/R	TRACC	D	OEM	6	VEL

FC-5R110W

5R110W



MODELO					AÑOS		
Pick ups Serie F, Super Duty, Excursion					03-07		
					MOTOR		
					V8		
TC	20	TRACC	T	OEM	3C3Z-7A098-AA	5	VEL

FC-5R110WCA

5R110W

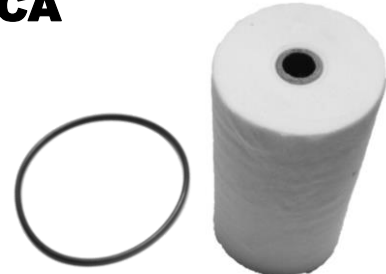

MODELO					AÑOS		
Ford F-250, F-350, F-450, F-550, Excursion, E-250, E-350					03-06		
					MOTOR		
					V8, V10		
TC	N/R	TRACC	T	OEM	3C3Z-7B155-BA	5	VEL

FC-5R110WN

5R110W



MODELO					AÑOS		
Ford Super Duty F-Series					08-12		
					MOTOR		
					V8 Diesel/V10		
TC	20	TRACC	T	OEM	8C3Z-7A098-D	5	VEL

FC-5R55N

5R55N



MODELO					AÑOS		
Lincoln LS, Jaguar S Type, Jaguar X Type					00-02		
					MOTOR		
					V8		
TC	16	TRACC	T	OEM	WX4Z-7A098-BB	5	VEL

1.4 Filtro y empaque de transmisión automática

Automatic transmission filter kits



Ford

FC-5R55S
5R55S



MODELO							AÑOS	
Mustang, Thunderbird							03-09	
							MOTOR	
							V8	
TC	16	TRACC	T	OEM	3W4Z-7A098AB	5	VEL	

FC-5R55W
5R55W



MODELO							AÑOS	
Mercury Mountaineer, Lincoln Aviator, Ford Explorer							02-05	
							MOTOR	
							L6, V8	
TC	16	TRACC	D	OEM	1L2Z-7A098AC	5	VEL	

FC-6F35
6F35



MODELO							AÑOS	
Ford Edge, Escape, Fusion							07-14	
							MOTOR	
							V6	
TC	N / R	TRACC	D/AWD	OEM	9L8P-7G186-CD	6	VEL	

FC-6F35L
6F35



MODELO							AÑOS	
Ford Edge, Explorer, Fusion, Escape, filtro de transmisión con cuello alto (0.600"),							12-16	
							MOTOR	
							L4 / V6	
TC	19	TRACC	D	OEM	BB5P-7G186-BC	6	VEL	

FC-6F35N
6F35



MODELO							AÑOS	
Ford Fusion, Escape, filtro de transmisión con cuello bajo							09-12	
							MOTOR	
							L4 / V6	
TC	19	TRACC	D	OEM	9L8P-7G186-DC	6	VEL	

FC-6R140
6R140



MODELO							AÑOS	
Ford F-250 Super Duty V8 6.7L diesel							11-18	
							MOTOR	
							V8	
TC	19	TRACC	T	OEM	BC3Z-7A098-B	6	VEL	

1.4 Filtro y empaque de transmisión automática

Automatic transmission filter kits



Ford

FC-6R60

6R60



MODELO		AÑOS
Ford Explorer, Mercury Mountaineer		06-08
		MOTOR
		V8

TC	21	TRACC	T	OEM	6L2P-7G186-AA	6	VEL
----	----	-------	---	-----	---------------	---	-----

FC-6R75

6R75 / 6R80

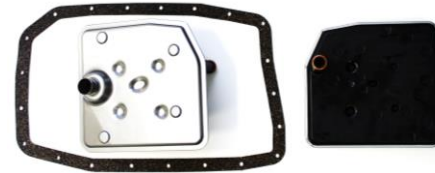

MODELO		AÑOS
Ford F-150, Lobo, Expedition Lincoln Navigator (filtro con cuello alto)		09-16
		MOTOR
		V6, V8

TC	21	TRACC	4WD	OEM	7L1Z-7A098-A	6	VEL
----	----	-------	-----	-----	--------------	---	-----

FC-6R80

6R75 / 6R80

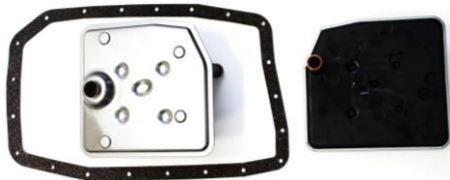

MODELO		AÑOS
Ford F-150, Lobo, Expedition, Lincoln Navigator (09-16), Mustang (11-17)		09-17
		MOTOR
		V6, V8

TC	21	TRACC	T	OEM	BL3Z-7A098-A	6	VEL
----	----	-------	---	-----	--------------	---	-----

FC-6T70

6F50N / 6F55



MODELO		AÑOS
Ford Edge, Taurus, Taurus X, Mercury Sable, Lincoln MKS		07-09
		MOTOR
		V6

TC	N / R	TRACC	D/AWD	OEM	7T4Z-7A098-B	6	VEL
----	-------	-------	-------	-----	--------------	---	-----

FC-A4LD

A4LD 4WD

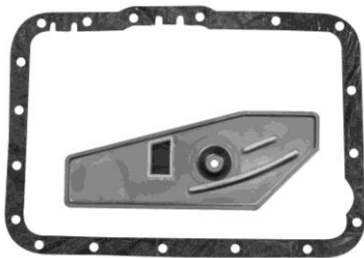

MODELO		AÑOS
Aerostar, Explorer, Ranger (4WD)		86-94
		MOTOR
		L4, V6

TC	18	TRACC	T	OEM	E6TZ-7A098-A	4	VEL
----	----	-------	---	-----	--------------	---	-----

FC-A4LDA

A4LD 2WD

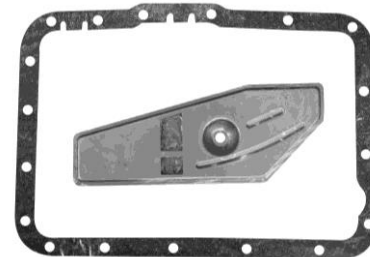

MODELO		AÑOS
Bronco II, Ranger		85-88
		MOTOR
		L4, V6

TC	18	TRACC	T	OEM	E6TZ-7A098B	4	VEL
----	----	-------	---	-----	-------------	---	-----

1.4 Filtro y empaque de transmisión automática

Automatic transmission filter kits



Ford

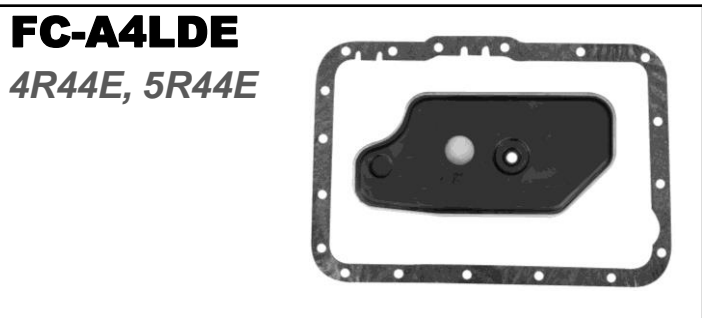

MODELO						AÑOS	
Explorer, Ranger, Mazda Pick Up B2300 (2WD)						95-06	
						MOTOR	
						L4, V6	
TC	18	TRACC	T	OEM	E9TZ-7A098-C	4	VEL



MODELO						AÑOS	
Explorer, Ranger, Mazda Pick Ups (4WD)						95-06	
						MOTOR	
						L4, V6	
TC	18	TRACC	T	OEM	3621456	4	VEL

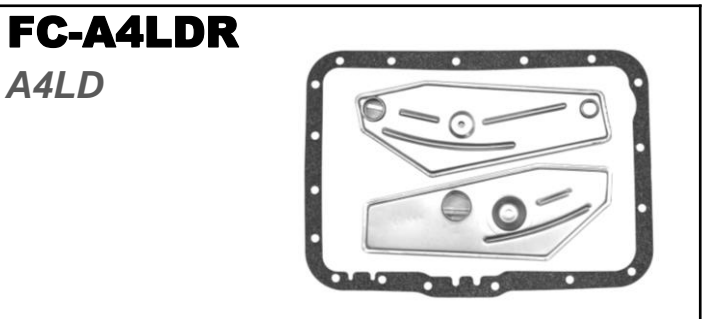

MODELO						AÑOS	
Aerostar, Explorer, Ranger						89-95	
						MOTOR	
						L4, V6	
TC	18	TRACC	T	OEM	E9TZ-7A098-C	4	VEL

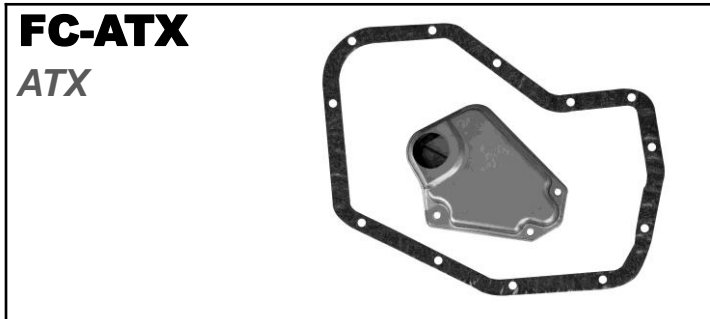

MODELO						AÑOS	
Topaz, Tempo, Sable, Taurus, Escort						81-94	
						MOTOR	
						L4	
TC	13	TRACC	D	OEM	E1EZ-7A098A	3	VEL



MODELO						AÑOS	
Taurus, Sable (sello verde)						96-06	
						MOTOR	
						V6	
TC	19	TRACC	D	OEM	F6DZ-7A098-A	4	VEL

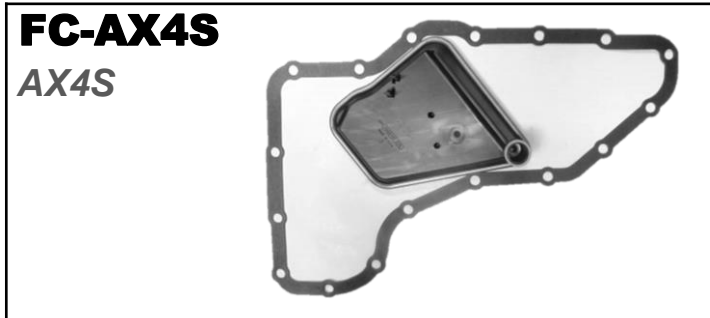

MODELO						AÑOS	
Lincoln Continental, Ford Windstar (sello naranja alto)						94-06	
						MOTOR	
						V8	
TC	17	TRACC	D	OEM	F5DZ-7A098-A	4	VEL

1.4 Filtro y empaque de transmisión automática

Automatic transmission filter kits



Ford

FC-AXOD

AXODE



MODELO						AÑOS	
Taurus, Sable, Windstar (sello naranja bajo)						91-01	
						MOTOR	
						V6	
TC	17	TRACC	D	OEM	E6DZ-7A098-A	4	VEL

FC-AXODA

AXOD



MODELO						AÑOS	
Taurus, Sable (tipo viejo)						86-90	
						MOTOR	
						V6	
TC	17	TRACC	D	OEM	E6DZ-7A098-A	3	VEL

FC-C3

C3



MODELO						AÑOS	
Fairmont, Mustang, Thunderbird						74-86	
						MOTOR	
						L4, V6	
TC	13	TRACC	T	OEM	D4ZZ-7A098-A	3	VEL

FC-C4

C4

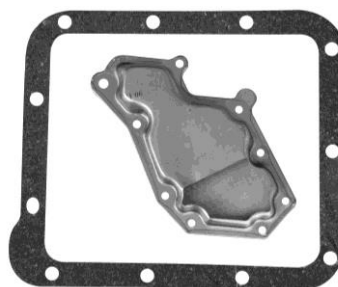

MODELO						AÑOS	
Fairmont, Pick Ups F-100, Mustang						70-82	
						MOTOR	
						L4, L6, V8	
TC	11	TRACC	T	OEM	D0DZ-7A098-B	3	VEL

FC-C4A

C4

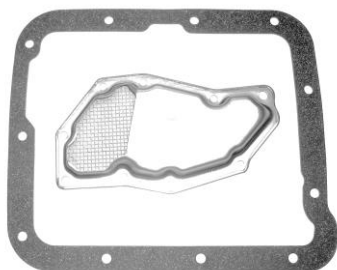

MODELO						AÑOS	
Ford, Mercury automóviles, Pick Ups, Vans						65-70	
						MOTOR	
						V6, V8	
TC	11	TRACC	T	OEM	D0DZ-7A098-B	3	VEL

FC-C4D

C4 (4WD)



MODELO						AÑOS	
Ford Bronco, Pick up F-100, F-150 (4WD)						70-82	
						MOTOR	
						L6, V8	
TC	11	TRACC	T	OEM	D3BZ-7A098-A	3	VEL

1.4 Filtro y empaque de transmisión automática

Automatic transmission filter kits



Ford

FC-C4N
C4



MODELO							AÑOS	
Ford Fairmont, Mustang, Pinto							74-80	
							MOTOR	
							L4, V6	
TC	11	TRACC	T	OEM	D4FZ-7A098-A	3	VEL	

FC-C5
C5



MODELO							AÑOS	
Cougar, Thunderbird , Pick Ups F-100, F-150							82-86	
							MOTOR	
							L4, V6	
TC	11	TRACC	T	OEM	E2AZ-7A098-A	3	VEL	

FC-C54
C5 (4WD)

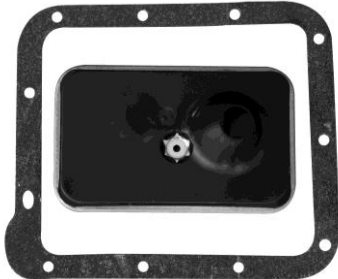

MODELO							AÑOS	
Pick Ups F-100, F-150 (4WD)							82-86	
							MOTOR	
							V6, V8	
TC	11	TRACC	T	OEM	E3TZ-7A098-A	3	VEL	

FC-C6
C6



MODELO							AÑOS	
Bronco, Pick Up F-100, F-150 (4WD)							73-96	
							MOTOR	
							V8	
TC	17	TRACC	T	OEM	D3TZ-7A098-A	3	VEL	

FC-C6A
C6 ANTIGUO



MODELO							AÑOS	
Galaxie, Pick Ups F-100							68-74	
							MOTOR	
							V8	
TC	17	TRACC	T	OEM	C6AZ-7A098-A	3	VEL	

FC-C6E
E4OD/4R100 2WD
(filtro metal/plástico)

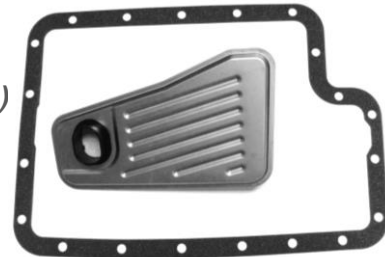

MODELO							AÑOS	
Expedition, Excursion, Lincoln Navigator, Pick ups F-150, Lobo							92-08	
							MOTOR	
							V8	
TC	20	TRACC	T	OEM	E9TZ-7A098A	4	VEL	

1.4 Filtro y empaque de transmisión automática

Automatic transmission filter kits



Ford

FC-C6EP

E40D / 4R100 / 2WD
(filtro de plástico)

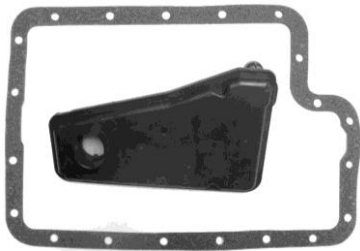

MODELO						AÑOS	
Ford F-150, F-250, F-350, Expedition, 2WD						92-08	
						MOTOR	
						V8	
TC	20	TRACC	T	OEM	YC3Z-7A098-AA	4	VEL

FC-C6N

C6 RECIENTE



MODELO						AÑOS	
Pick ups F-100, F-150, LTD, Mercury Marquis						75-96	
						MOTOR	
						V6, V8	
TC	17	TRACC	T	OEM	D5AZ-7A098-AA	3	VEL

FC-CD4E

CD4E



MODELO						AÑOS	
Contour, Mystique, Escape, Probe (2WD, 4WD)						95-06	
						MOTOR	
						L4	
TC	14	TRACC	D	OEM	F3RZ-7A098-A	4	VEL

FC-CFT23

CVT



MODELO						AÑOS	
Ford Focus C-Max						03-10	
						MOTOR	
						L4	
TC	N/R	TRACC	D	OEM	0501-214-113	CVT	VEL

FC-CFT30

CFT30

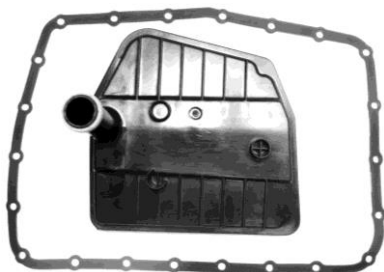

MODELO						AÑOS	
Ford Five Hundred, Freestyle, Mercury Montego						05-07	
						MOTOR	
						V6	
TC	22	TRACC	D/AWD	OEM	5F9Z-7A098A	CVT	VEL

FC-E40D4W

E40D/4R100 4WD
(filtro metal/plástico)



MODELO						AÑOS	
Expedition, Excursion, Lincoln Navigator Pick ups F-150, F-250, Lobo						92-08	
						MOTOR	
						V8	
TC	20	TRACC	T	OEM	E9TZ-7A098B	4	VEL

1.4 Filtro y empaque de transmisión automática

Automatic transmission filter kits



Ford

FC-E40D4WP

EOD/ 4R100 (4WD)
(filtro de plástico)



MODELO					AÑOS		
Lobo, Expedition, Lincoln Navigator Pick ups F-150, F-250, Lobo					92-08		
					MOTOR		
					V6, V8		
TC	20	TRACC	T	OEM	F6TZ-7A098-BB	4	VEL

FC-F3A

F3A

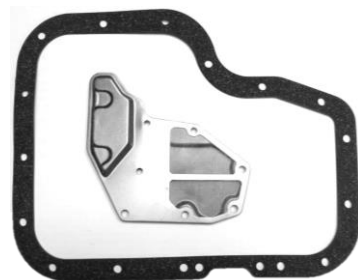

MODELO					AÑOS		
Mercury Tracer					87-90		
					MOTOR		
					L4		
TC	18	TRACC	T	OEM	E7GZ-7A098-A	3	VEL

FC-F3AATX



MODELO					AÑOS		
Aspire					94-97		
					MOTOR		
					L4		
TC	18	TRACC	D	OEM	F4BZ-7A098-A	3	VEL

FC-F3AE

F3A / MX1



MODELO					AÑOS		
Ford Festiva, Mercury Tracer					87-93		
					MOTOR		
					L4		
TC	18	TRACC	D	OEM	E7GZ-7A098-A	3	VEL

FC-F3AF

F3A



MODELO					AÑOS		
Ford Festiva					89-93		
					MOTOR		
					L4		
TC	18	TRACC	D	OEM	E9BZ-7A098-A	3	VEL

FC-FIOD

AOD (2WD)



MODELO					AÑOS		
Cougar, Thunderbird, Grand Marquis, Bronco, Pick ups F-100, F-150 (2WD), Vans Serie "E" (2WD)					81-92		
					MOTOR		
					V6, V8		
TC	14	TRACC	T	OEM	E1AZ-7A098-A	4	VEL

1.4 Filtro y empaque de transmisión automática

Automatic transmission filter kits



Ford

FC-FIOD4 AOD (4WD)



MODELO

AÑOS

Pick F-100, F-150, Bronco (4WD)

81-92

MOTOR

V6, V8

TC 14 TRACC T OEM E5TZ-7A098-C 4 VEL

FC-FIOD4E AODE (4R70W)



MODELO

AÑOS

Explorer (4WD), Expedition,
Lobo, Pick ups F-150, F-250 (4WD)

93-10

MOTOR

V6, V8

TC 14 TRACC T OEM F4TZ-7A098-A 4 VEL

FC-FIODE AODE (4R70W)



MODELO

AÑOS

Grand Marquis, Cougar, Thunderbird,
Pick up F-150, Lobo (2WD)

93-10

MOTOR

V6, V8

TC 14 TRACC T OEM F2VY-7A098-A 4 VEL

FC-FMX FMX (LATON)

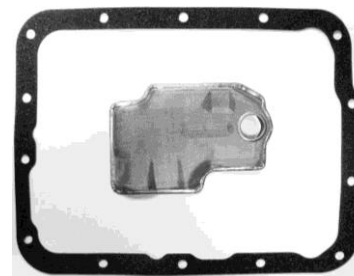

MODELO

AÑOS

Galaxie, LTD, Mustang

68-79

MOTOR

V6, V8

TC 14 TRACC T OEM D0AZ-7A098-A 3 VEL

FC-FMXF FMX (FELPA)



MODELO

AÑOS

Ford LTD, Mustang,
Mercury Marquis

69-81

MOTOR

V8

TC 14 TRACC T OEM D8AZ-7A098-AB 3 VEL

FC-FNR5 FNR5



MODELO

AÑOS

Ford Fusion, Lincoln Zephyr,
Mercury Milan

06-08

MOTOR

L4, V6

TC 20 TRACC D OEM FNC1-21-500 5 VEL

1.4 Filtro y empaque de transmisión automática

Automatic transmission filter kits



Ford

FC-G4AHL
G4A-HL
(1.250" ALTO)

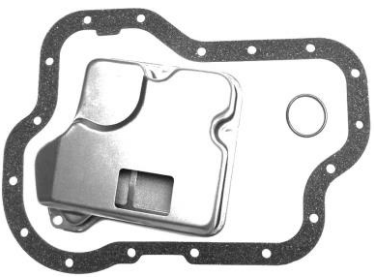

MODELO					AÑOS		
Ford Probe, Mercury Capri, Mazda 323					88-92		
					MOTOR		
					L4		
TC	17	TRACC	D	OEM	FU50-21-500A	4	VEL

FC-JF506E
JF506E



MODELO					AÑOS		
Ford Mondeo					03-06		
					MOTOR		
					V6		
TC	20	TRACC	D	OEM	6L2P-7G186-AA	5	VEL

FC-TF81SC
AWTF81SC



MODELO					AÑOS		
Ford Fusion, Five Hundred, Freestyle, Mercury Milan, Montego, Mariner					05-09		
					MOTOR		
					L4, V6		
TC	12	TRACC	D/AWD	OEM	60-27-0F099-0080	6	VEL

General Motors

FC-320
ZF4HP16

NUEVO PRODUCTO



MODELO					AÑOS		
Optra 1.8L, Epica 2.0L					03-12		
					MOTOR		
					L4		
TC	N/R	TRACC	D	OEM		4	VEL

FC-321
6T30E

NUEVO PRODUCTO



MODELO					AÑOS		
Cruze 1.6L, 1.8L, 2.0L					09-14		
					MOTOR		
					L4		
TC	N/R	TRACC	D	OEM		6	VEL

1.4 Filtro y empaque de transmisión automática

Automatic transmission filter kits



General Motors

FC-322

AW80-40LS



MODELO					AÑOS	
Chevrolet Spark					13-15	
					MOTOR	
					L4	
TC	N/R	TRACC	D	OEM	4	VEL

FC-4L30E

4L30E



MODELO					AÑOS		
GM Pick Ups Luv					90-06		
					MOTOR		
					L4		
TC	16	TRACC	T	OEM	8-96015-062-0	4	VEL

FC-4L30E6

4L30E



MODELO					AÑOS		
Cadillac Catera, BMW					97-01		
					MOTOR		
					V6		
TC	16	TRACC	T	OEM	96015431	4	VEL

FC-4L60E

4L60E



MODELO					AÑOS		
Corvette					97-04		
					MOTOR		
					V8		
TC	16	TRACC	T	OEM	24207600	4	VEL

FC-4L60EA

4L60E

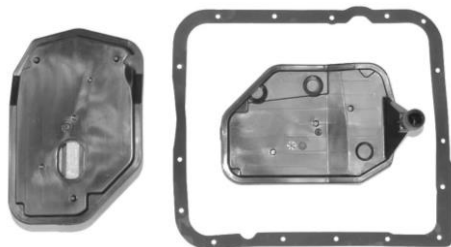

MODELO					AÑOS		
Colorado, GMC Canyon, Hummer H3					04-09		
					MOTOR		
					V6		
TC	16	TRACC	T	OEM	24225323	4	VEL

FC-4L60EB

4L60E

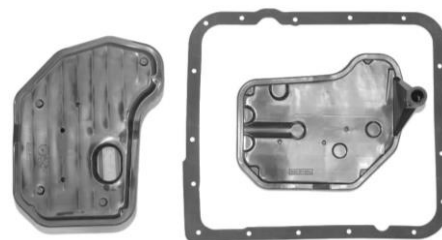

MODELO					AÑOS		
Cheyenne, Silverado, Suburban, Tahoe, Sonora					03-10		
					MOTOR		
					V8		
TC	16	TRACC	T	OEM	24208813	4	VEL

1.4 Filtro y empaque de transmisión automática

Automatic transmission filter kits



General Motors

FC-4L60EH
4L60E



MODELO							AÑOS	
Cadillac Escalade, Silverado, Sierra Tahoe, Yukon V8 6.0L transmisión hibrida 2ML70							08-09	
							MOTOR	
							V8	
TC	16	TRACC	T	OEM	24227080	4	VEL	

FC-4L80E
4L80E



MODELO							AÑOS	
Suburban, Pick ups							91-96	
							MOTOR	
							V8	
TC	17	TRACC	T	OEM	8678757	4	VEL	

FC-4L80ER2
4L80E



MODELO							AÑOS	
Suburban, Avalanche 2500, Pick Ups 2500, 3500 Express Van 2500, 3500							97-10	
							MOTOR	
							V8	
TC	17	TRACC	T	OEM	24204277	4	VEL	

FC-4T40E
4T40E



MODELO							AÑOS	
Chevrolet Cavalier, Malibu, Pontiac Sunfire, Grand Am,							95-05	
							MOTOR	
							L4, V6	
TC	12	TRACC	D	OEM	24221762	4	VEL	

FC-4T45E
4T45E



MODELO							AÑOS	
Buick Lacrosse, Lacrosse II							06-14	
							MOTOR	
							V6	
TC	12	TRACC	D	OEM	24221762	4	VEL	

FC-4T80E
4T80E



MODELO							AÑOS	
Cadillac DeVille, Seville							93-04	
							MOTOR	
							V8	
TC	16	TRACC	D	OEM	8681416	4	VEL	

1.4 Filtro y empaque de transmisión automática

Automatic transmission filter kits



General Motors

FC-4T80E2

4T80E



MODELO

AÑOS

Cadillac De Ville , Seville

93-04

MOTOR

V8

TC 16 TRACC D OEM 8681416 4 VEL

FC-4W60

AW60-40LE



MODELO

AÑOS

Chevy, Chevy Monza, Astra,
Saab 9-3, 9-5

99-10

MOTOR

L4

TC 12 TRACC D OEM 26445-60G10 4 VEL

FC-6L80

6L80



MODELO

AÑOS

Silverado, Sierra, Suburban, Tahoe, Yukon,
Corvette, Avalanche, Escalade

06-09

MOTOR

V8

TC 18 TRACC T OEM 24236933 6 VEL

FC-6L80E

6L80E



MODELO

AÑOS

Cadillac ATS (13-14), Chevrolet Caprice,
Pontiac G8

08-14

MOTOR

V8

TC 18 TRACC OEM 24235900 6 VEL

FC-6L90

6L90



MODELO

AÑOS

Tahoe, Yukon, Silverado, Suburban

07-12

MOTOR

V8

TC 18 TRACC T OEM 24236933 6 VEL

FC-6T40E

6T40E



MODELO

AÑOS

Chevrolet Malibu, Cruze, Captiva,
Buick LaCrosse

08-14

MOTOR

L4

TC 17 TRACC D OEM 24230708 6 VEL

1.4 Filtro y empaque de transmisión automática

Automatic transmission filter kits



General Motors

FC-6T70
6T70E / 6T75E



MODELO					AÑOS		
Acadia, Equinox Sport, Malibu, Traverse, Sonic Buick LaCrosse					07-09		
					MOTOR		
					V6		
TC	NR	TRACC	D/AWD	OEM	24223670	6	VEL

FC-8L45
8L45 / 8L90



MODELO					AÑOS		
Chevrolet Camaro Colorado, Cadillac ATS, CTS, CT6, GMC Canyon					16-18		
					MOTOR		
					V6, V8		
TC	15	TRACC	T	OEM	24268875	8	VEL

FC-8L90
8L90



MODELO					AÑOS		
Chevrolet Silverado, Cheyenne, GMC Sierra V8 5.3L, 6.2L; Colorado V6 3.6L Camaro V6 3.6L, V8 6.2L					15-18		
					MOTOR		
					V6 / V8		
TC	15	TRACC	T	OEM	24274402	8	VEL

FC-A43DE
A43DE



MODELO					AÑOS		
Geo Tracker					96-98		
					MOTOR		
					Todos		
TC	14	TRACC	T	OEM	26582-57800	4	VEL

FC-AW55
AW55-50SN



MODELO					AÑOS		
Chevrolet Equinox, Pontiac Torrent					05-09		
					MOTOR		
					V6		
TC	NR	TRACC	D/T	OEM	24220578	5	VEL

FC-AW81
AW81-40LE / ML4

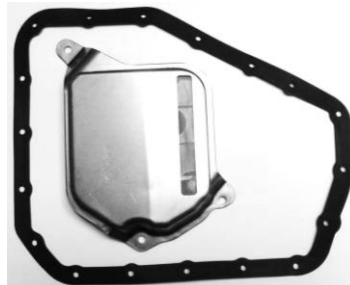

MODELO					AÑOS		
Chevrolet Aveo, Pontiac Wave Pontiac G3					07-17		
					MOTOR		
					L4		
TC	18	TRACC	D	OEM	93741509	4	VEL

1.4 Filtro y empaque de transmisión automática

Automatic transmission filter kits



General Motors

FC-F3AG

F3A

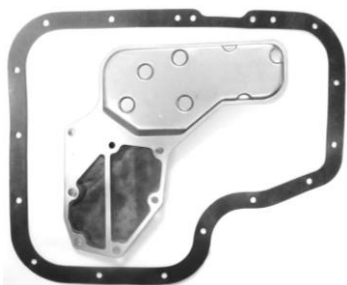

MODELO

AÑOS

Geo Spectrum

85-88

MOTOR

L4

TC 18 TRACC D OEM 94140860 3 VEL

FC-JF403E

JF403E



MODELO

AÑOS

Geo Storm, Isuzu Impulse

90-93

MOTOR

L4

TC 21 TRACC D OEM 94385937 4 VEL

FC-MX1

MX1, F3A



MODELO

AÑOS

Geo Spectrum, Isuzu Stylus

85-93

MOTOR

L4

TC 18 TRACC D OEM 94428489 3 VEL

FC-MX17

MX17, MX1

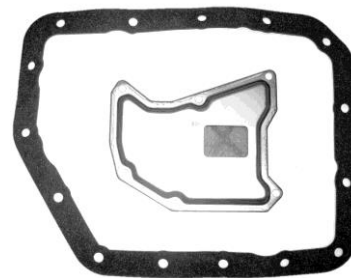

MODELO

AÑOS

GEO Metro, Suzuki Swift

89-01

MOTOR

L3, L4

TC 15 TRACC D OEM 96053975 3 VEL

FC-PWRGLIDE

POWERGLIDE

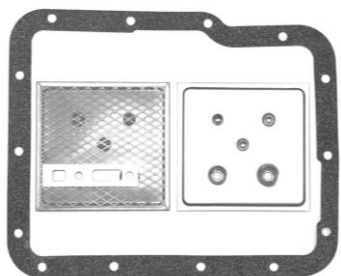

MODELO

AÑOS

Bel-Air, Camaro, Chevelle,
Impala, Pick up C-10

63-73

MOTOR

V8

TC 14 TRACC T OEM 6438815 2 VEL

FC-TAAT

TAAT



MODELO

AÑOS

Saturn S series

91-01

MOTOR

L4

TC NR TRACC D OEM 21002496 4 VEL

1.4 Filtro y empaque de transmisión automática

Automatic transmission filter kits



General Motors

FC-TAATCA
TAAT



MODELO						AÑOS	
Todos los modelos Cartucho GM Silverado, Saturn						91-01	
						MOTOR	
						Todos	
TC	NR	TRACC	D	OEM	21002303	4	VEL

FC-TH125
TH-125C/3T40



MODELO						AÑOS	
Chevrolet, Buick , Isuzu, Oldsmobile, Pontiac						80-02	
						MOTOR	
						L4	
TC	16	TRACC	D	OEM	25010991	3	VEL

FC-TH180
TH-180 (3L30)

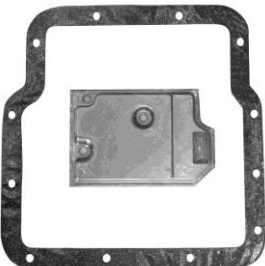

MODELO						AÑOS	
Geo Tracker 2WD, 4WD, Chevette, Pick Up Luv						72-98	
						MOTOR	
						L4, V6	
TC	12	TRACC	T	OEM	26950-61-A00	3	VEL

FC-TH200L
TH-200

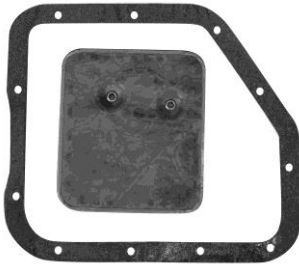

MODELO						AÑOS	
Malibu, Impala						77-79	
						MOTOR	
						V6, V8	
TC	11	TRACC	T	OEM	8628299	3	VEL

FC-TH200NY
TH-200C

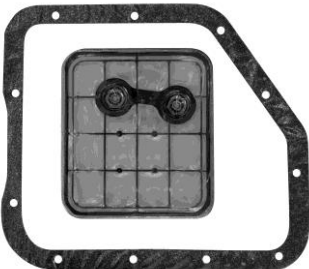

MODELO						AÑOS	
S-10 Pick Ups, Pick Up Isuzu, Caprice, Malibu						79-85	
						MOTOR	
						V6, V8	
TC	11	TRACC	T	OEM	8630789	3	VEL

FC-TH200R4
TH-2004R



MODELO						AÑOS	
Malibú, Caprice, Impala, Monte Carlo						81-90	
						MOTOR	
						V6, V8	
TC	16	TRACC	T	OEM	8629951	4	VEL

1.4 Filtro y empaque de transmisión automática

Automatic transmission filter kits



General Motors

FC-TH325

TH325

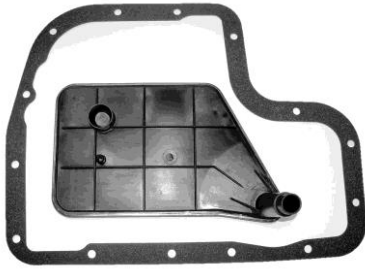

MODELO

AÑOS

Cadillac Seville,
Oldsmobile Toronado

79-81

MOTOR

V8

TC 14 TRACC D OEM 8632630 3 VEL

FC-TH325N

TH325-4L



MODELO

AÑOS

Buick Riviera, Cadillac El Dorado,
Cadillac Seville, Oldsmobile Toronado

82-85

MOTOR

V6, V8

TC 15 TRACC D OEM 8365710 4 VEL

FC-TH350C

TH350

TH350C

TH375B



MODELO

AÑOS

Buick Century, Regal,
Caprice, Impala

75-83

MOTOR

V6, V8

TC 13 TRACC T OEM 8641910 3 VEL

FC-TH350L

TH-350

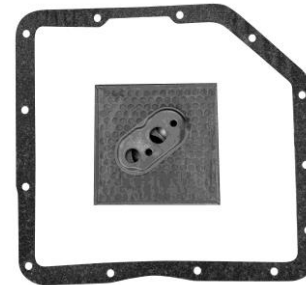

MODELO

AÑOS

Pick ups C-10, Caprice, Impala, Malibu
(malla de latón)

69-86

MOTOR

V6, V8

TC 13 TRACC T OEM 6261412 3 VEL

FC-TH350NY

TH-350

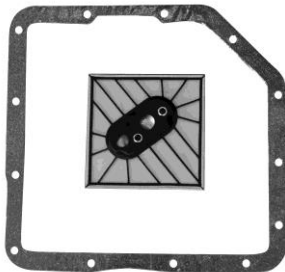

MODELO

AÑOS

Pick ups C-10, Caprice, Impala, Malibu
(malla de nylon)

69-86

MOTOR

V6, V8

TC 13 TRACC T OEM 8640848 3 VEL

FC-TH400

TH-400 / 3L80

(FELPA)



MODELO

AÑOS

GM Pick ups C-10, C-20, C-30,
Suburban

68-90

MOTOR

V8

TC 13 TRACC T OEM 6437741 3 VEL

1.4 Filtro y empaque de transmisión automática

Automatic transmission filter kits



General Motors

FC-TH400A
TH400 (ANTIGUO)



MODELO					AÑOS		
GM autos y pick ups					64-67		
					MOTOR		
					L6, V8		
TC	13	TRACC	T	OEM	5579822	3	VEL

FC-TH400L
TH400 (LATON)



MODELO					AÑOS		
GM autos y pick ups (malla de latón)					68-90		
					MOTOR		
					L6, V8		
TC	13	TRACC	T	OEM	6437741	3	VEL

FC-TH425
TH425 (M40E)



MODELO					AÑOS		
Cadillac El Dorado, Oldsmobile Toronado					67-78		
					MOTOR		
					V8		
TC	13	TRACC	D	OEM	6435766	3	VEL

FC-TH440N
4T60



MODELO					AÑOS		
Century, Cutlass, Celebrity					84-94		
					MOTOR		
TC	19	TRACC	D	OEM	8689918	4	VEL

FC-TH700A
TH700 R4



MODELO					AÑOS		
Caprice, Impala					82-87		
					MOTOR		
					V6, V8		
TC	16	TRACC	T	OEM	8634223	4	VEL

FC-TH700E
4L60E

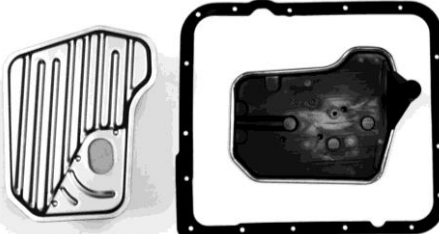

MODELO					AÑOS		
Suburban, Pick Ups					93-97		
					MOTOR		
					V8		
TC	16	TRACC	T	OEM	24200796	4	VEL

1.4 Filtro y empaque de transmisión automática

Automatic transmission filter kits



General Motors

FC-TH700E6

4T60E/4T65E



MODELO

AÑOS

Buick LaCrosse, Century, Cutlass,
Venture

93-09

MOTOR

V6

TC	20	TRACC	D	OEM	8651909	4	VEL
----	----	-------	---	-----	---------	---	-----

FC-TH700E8N

4L60E



MODELO

AÑOS

Suburban, Sonora,
Express Van 1500, 2500, Silverado

98-02

MOTOR

L4, V6, V8

TC	16	TRACC	T	OEM	24208576	4	VEL
----	----	-------	---	-----	----------	---	-----

FC-TH700EP

4L60E

(filtro de plástico)



MODELO

AÑOS

Cheyenne, Silverado, Suburban

93-97

MOTOR

V6, V8

TC	16	TRACC	T	OEM	24208835	4	VEL
----	----	-------	---	-----	----------	---	-----

FC-TH700N

TH700 R4 / 4L60



MODELO

AÑOS

Astro, Suburban,
Pick ups Cheyenne , C-10, C-20, C1500

82-92

MOTOR

V6, V8

TC	16	TRACC	T	OEM	8657926	4	VEL
----	----	-------	---	-----	---------	---	-----

FC-VT25E

CVT

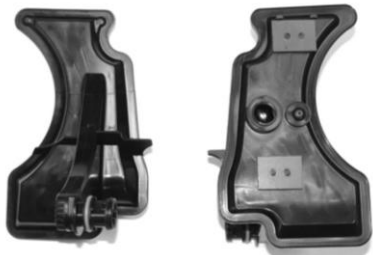

MODELO

AÑOS

Saturn

02-06

MOTOR

L4

TC	N / R	TRACC	D	OEM	24226576	CVT	VEL
----	-------	-------	---	-----	----------	-----	-----

1.4 Filtro y empaque de transmisión automática

Automatic transmission filter kits



Honda

FC-APX4
APX4, MPJA

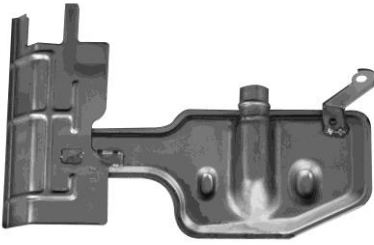

MODELO						AÑOS	
Accord, CRX						88-92	
						MOTOR	
TC	NR	TRACC	D	OEM	25420-PX4-023	4	VEL

FC-B7XA
B7XA



MODELO						AÑOS	
Accord, Odyssey						98-02	
						MOTOR	
TC	NR	TRACC	D	OEM	25420-P7X-003	4	VEL

FC-B97A
B97A



MODELO						AÑOS	
Honda Accord, Pilot, Odyssey						11-12	
						MOTOR	
TC	N / R	TRACC	D	OEM	25420-R36-003	5	VEL

FC-BAXA
BAXA

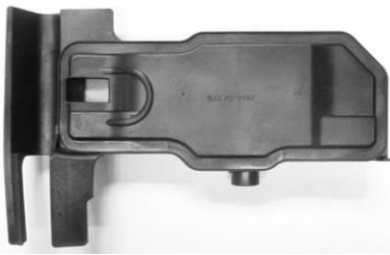

MODELO						AÑOS	
Accord, Odyssey, Prelude						97-02	
						MOTOR	
TC	NR	TRACC	D	OEM	25420-PAX-003	4	VEL

FC-BDGA
BGRA



MODELO						AÑOS	
Honda Odyssey EX						05-09	
						MOTOR	
TC	NR	TRACC	D	OEM	25450-RAY-003	5	VEL

1.4 Filtro y empaque de transmisión automática

Automatic transmission filter kits



Honda

FC-346

5AT



MODELO

AÑOS

Accord 2.4L, 3.0L, Element 2.4L,
CR-V 2.4L,

02-07

MOTOR

L4, V6

TC	N/R	TRACC	D	OEM	5	VEL
----	-----	-------	---	-----	---	-----

FC-347

BMXA



MODELO

AÑOS

Civic DX 1.7L

01-05

MOTOR

L4

TC	N/R	TRACC	D	OEM	4	VEL
----	-----	-------	---	-----	---	-----

FC-348

BGHA



MODELO

AÑOS

Accord 3.0L

02-07

MOTOR

V6

TC	N/R	TRACC	D	OEM	5	VEL
----	-----	-------	---	-----	---	-----

FC-349

MWWA



MODELO

AÑOS

Odyssey 3.5L

03-08

MOTOR

V6

TC	N/R	TRACC	D	OEM	CVT	VEL
----	-----	-------	---	-----	-----	-----

FC-350

ECVT



MODELO

AÑOS

Accord
2.4L, 3.5L

13-14

MOTOR

L4, V6

TC	14	TRACC	D	OEM	CVT	VEL
----	----	-------	---	-----	-----	-----

FC-A24A

A24A, M24A

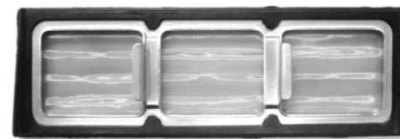

MODELO

AÑOS

Civic, CRX

88-97

MOTOR

L4

TC	NR	TRACC	D	OEM	25420-P24-J01	4	VEL
----	----	-------	---	-----	---------------	---	-----

1.4 Filtro y empaque de transmisión automática

Automatic transmission filter kits



Honda

FC-BDKA
BDKA

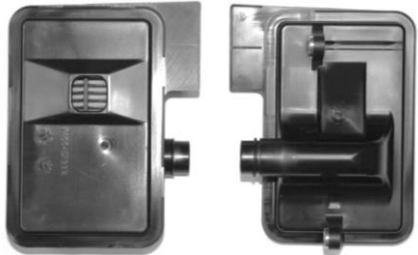

MODELO		AÑOS					
Honda Civic, Fit		06-15					
		MOTOR					
		L4					
TC	N / R	TRACC	D	OEM	25420-RPC-003	5	VEL

FC-BVLA
BVGA



MODELO		AÑOS					
Honda Pilot EX		03-09					
		MOTOR					
		V6					
TC	NR	TRACC	D/AWD	OEM	25420-RDP-003	5	VEL

FC-CVTH
CVT

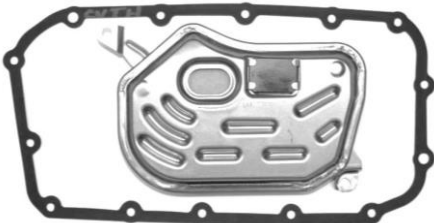

MODELO		AÑOS					
Honda Civic HX		96-05					
		MOTOR					
		L4					
TC	14	TRACC	D	OEM	25420-PET-003	CVT	VEL

FC-G4
G4 / L5 / CA / AS



MODELO		AÑOS					
Accord, Civic, CRX, Prelude		83-91					
		MOTOR					
		L4					
TC	NR	TRACC	D	OEM	25420-PC9-010	4	VEL

FC-HONDA3
HONDAMATIC



MODELO		AÑOS					
Accord, Civic, Prelude		79-85					
		MOTOR					
		L4					
TC	NR	TRACC	D	OEM	25420-PA9-000	3	VEL

FC-HONDAMATIC
HONDAMATIC

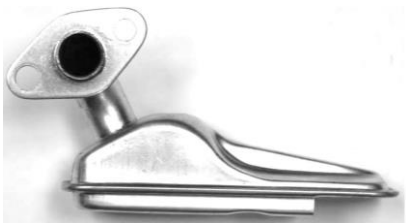

MODELO		AÑOS					
Accord, Civic, CRX, Prelude		73-85					
		MOTOR					
		L4					
TC	N/R	TRACC	D	OEM	25420-639-000	2	VEL

1.4 Filtro y empaque de transmisión automática

Automatic transmission filter kits



Honda

FC-K4

K4 / MY8A / PY8A

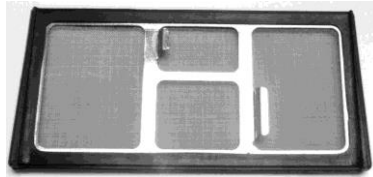

MODELO

AÑOS

Prelude

88-89

MOTOR

L4

TC NR TRACC D OEM 25420-PK4-000 4 VEL

FC-M4TA

M4VA



MODELO

AÑOS

CR-V

94-00

MOTOR

L4

TC NR TRACC D OEM 25420-P56-003 4 VEL

FC-M4VA

M4VA (CVT)

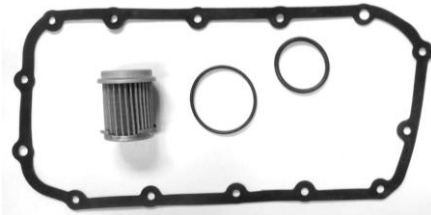

MODELO

AÑOS

Civic

96-00

MOTOR

L4

TC 14 TRACC D OEM 25450-P4V-013 4 VEL

FC-M4VAP

M4VA

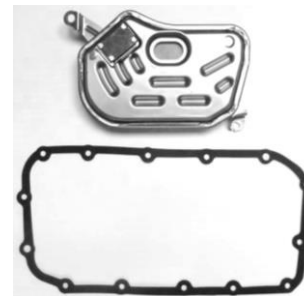

MODELO

AÑOS

Civic HX

96-00

MOTOR

L4

TC 14 TRACC D OEM 25420-P4V-003 CVT VEL

FC-M7WA

BYBA / M7WA



MODELO

AÑOS

Odyssey

02-04

MOTOR

V6

TC NR TRACC D OEM 25420-P7W-003 5 VEL

FC-M91A

M91A

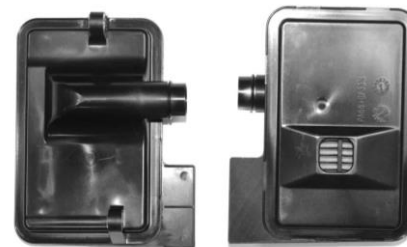

MODELO

AÑOS

Honda Accord, CR-V, Element

07-12

MOTOR

L4

TC N / R TRACC D/AWD OEM 25420-RXH-003 5 VEL

1.4 Filtro y empaque de transmisión automática

Automatic transmission filter kits



Honda

FC-MDLA
MDLA/MDWA



MODELO							AÑOS	
CR-V							99-03	
							MOTOR	
							L4	
TC	NR	TRACC	D	OEM	25420-P4R-013	4	VEL	

FC-ML4A
ML4A



MODELO							AÑOS	
Honda CRX, Acura Integra							88-91	
							MOTOR	
							L4	
TC	N/R	TRACC	D	OEM	25420-PL4-000	4	VEL	

FC-MPJACA
MPJA
(Filtro sellado)



MODELO							AÑOS	
Accord, Civic, CR-V, Odyssey, Pilot							01-07	
							MOTOR	
							V6	
TC	N/R	TRACC	D	OEM	25450-P7W-003	4	VEL	

FC-MPRA
MPRA / MR9A

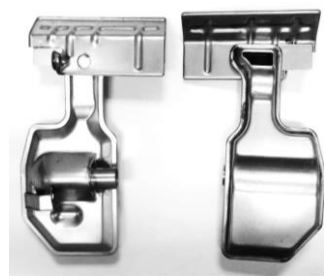

MODELO							AÑOS	
Acura NSX, Acura Integra							91-98	
							MOTOR	
							V6	
TC	N/R	TRACC	D	OEM	25420-PR9-010	4	VEL	

FC-MPWA
MPWA / M1WA

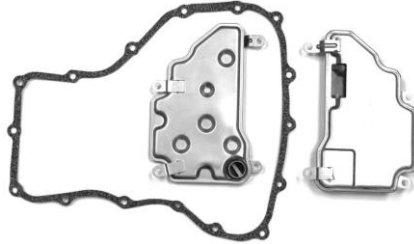

MODELO							AÑOS	
Acura TL, Vigor							92-99	
							MOTOR	
							L5	
TC	16	TRACC	D	OEM	25420-PW4-010	4	VEL	

FC-MPXA
PX4B / MPXA

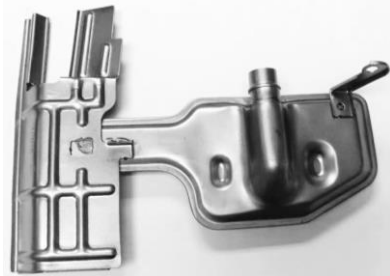

MODELO							AÑOS	
Accord, Prelude, Odyssey							91-97	
							MOTOR	
							L4	
TC	N/R	TRACC	D	OEM	25420-PX4-701	4	VEL	

1.4 Filtro y empaque de transmisión automática

Automatic transmission filter kits



Honda

FC-MPYA

MPYA

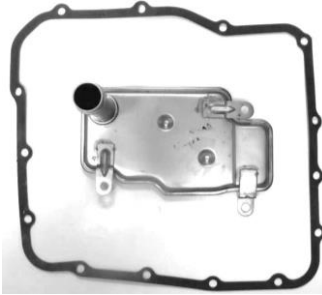

MODELO

AÑOS

Acura Legend

91-95

MOTOR

L4

TC 14 TRACC D OEM 25420-PY4-000 4 VEL

FC-MURA

MURA



MODELO

AÑOS

Honda Accord DX, EX,
(hibrido)

06-11

MOTOR

V6

TC N / R TRACC D OEM 25420-RCK-004 5 VEL

FC-MV2A

MV2A



MODELO

AÑOS

Honda Odyssey, Accord

11-15

MOTOR

V6

TC N / R TRACC D OEM 25420-RV2-003 6 VEL

FC-PN3A

PN3A



MODELO

AÑOS

Honda Pilot,
Acura TL

09-14

MOTOR

V6

TC N / R TRACC T OEM 25420-RN3-003 5 VEL

FC-SLYA

SLYA



MODELO

AÑOS

Civic GX, HX

01-05

MOTOR

L4

TC 14 TRACC D OEM 25420-PLY-003 CVT VEL

FC-SMMA

SMMA

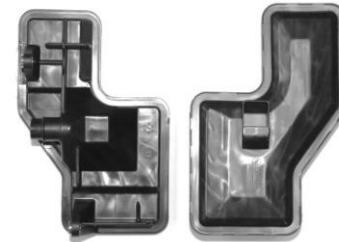

MODELO

AÑOS

Honda Fit, Element

07-11

MOTOR

L4

TC N / R TRACC D OEM 25420-PWR-003 5 VEL

1.4 Filtro y empaque de transmisión automática

Automatic transmission filter kits



Honda

FC-SMMACA
SMMACA



MODELO		AÑOS
Honda Fit, Honda Element (cartucho)		07-11
		MOTOR
		L4

TC	N/R	TRACC	D	OEM	25450-PWR-003	5	VEL
----	-----	-------	---	-----	---------------	---	-----

FC-SPCA
SPCA

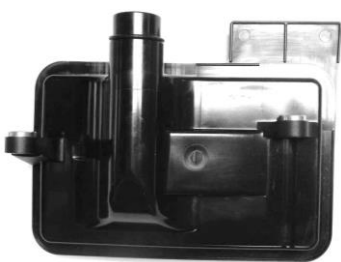

MODELO		AÑOS
Civic		06-09
		MOTOR
		L4

TC	N/R	TRACC	D	OEM	25420-RPC-003	5	VEL
----	-----	-------	---	-----	---------------	---	-----

FC-SZCA
CVT



MODELO		AÑOS
Honda Civic (hibrido)		03-09
		MOTOR
		L4

TC	N/R	TRACC	D	OEM	25420-PHT-003	CVT	VEL
----	-----	-------	---	-----	---------------	-----	-----

Hyundai

FC-363
6F24



NUEVO PRODUCTO

MODELO		AÑOS
Accent 1.6L , Elantra 2.0L , Santa Fe 2.4L		16-20
		MOTOR
		L4

TC	N/R	TRACC	D	OEM		6	VEL
----	-----	-------	---	-----	--	---	-----

FC-A4AF1
F4A32



MODELO		AÑOS
Accent, Elantra, Tiburon, Scoupe		93-99
		MOTOR
		L4

TC	13	TRACC	D	OEM	46321-22050	4	VEL
----	----	-------	---	-----	-------------	---	-----

1.4 Filtro y empaque de transmisión automática

Automatic transmission filter kits



Hyundai

FC-F4A21

F4A32



MODELO

AÑOS

Accent, Scoupe

93-99

MOTOR

L4

TC 13 TRACC D OEM 46321-22731 4 VEL

FC-KM177

KM171 / KM177



MODELO

AÑOS

Hyundai Excel

87-94

MOTOR

L4

TC 12 TRACC D OEM MD729954 4 VEL

FC-F4A51T

F4A32 / F4A42
F4A51 / F5A51

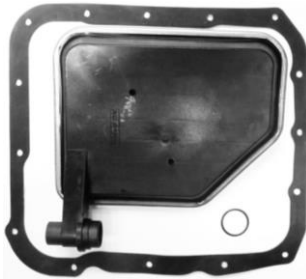

MODELO

AÑOS

Accent, Elantra, Sonata, Tiburon,
XG300, Santa Fe, Tucson

95-13

MOTOR

L4, V6

TC 15 TRACC T OEM 46321-39010 5 VEL

Isuzu

FC-4L30E

4L30E



MODELO

AÑOS

Amigo, Rodeo, Trooper, Pick up Luv

91-06

MOTOR

V-6

TC 16 TRACC T OEM 8-96015-062-0 4 VEL

FC-AW450

AW450-43LE



MODELO

AÑOS

Isuzu Truck NPR

98-06

MOTOR

L4

TC 20 TRACC T OEM 8-97202-067-0 4 VEL

1.4 Filtro y empaque de transmisión automática

Automatic transmission filter kits



Isuzu

FC-F3AG
F3A

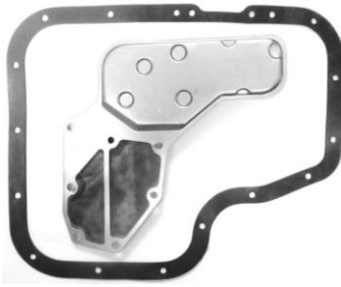

MODELO						AÑOS	
Isuzu I-Mark						85-89	
						MOTOR	
						L4	
TC	18	TRACC	D	OEM	94413320	3	VEL

Jaguar

FC-BWT66
BW-T65 / 66



MODELO						AÑOS	
Jaguar XJ6						76-87	
						MOTOR	
						L6	
TC	12	TRACC	T	OEM	3188896	3	VEL

FC-JF506E
JF506E



MODELO						AÑOS	
X Type						02-08	
						MOTOR	
						V6	
TC	20	TRACC	AWD	OEM	FP01-21-500	5	VEL

FC-ZF5HP30
ZF5HP30



MODELO						AÑOS	
Jaguar XJR						98-00	
						MOTOR	
						V8	
TC	23	TRACC	T	OEM	24341-422-419	5	VEL

1.4 Filtro y empaque de transmisión automática

Automatic transmission filter kits



Kia

FC-F4AEL

F4A-EL

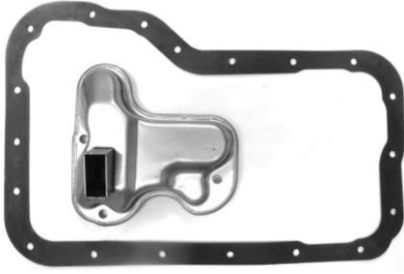

MODELO

AÑOS

Rio, Spectra

00-09

MOTOR

L4

TC 19 TRACC D OEM KFW01-21-500 4 VEL

FC-F4A51T

F4A32 / F4A42
F4A51 / F5A51



MODELO

AÑOS

Amanti, Magentis, Optima,
Spectra, Sorento, Sportage

01-06

MOTOR

L4-V6

TC 15 TRACC T OEM 46321-39010 4 y 5 VEL

Land Rover

FC-4HP22R

ZF4HP22

(Tubo de 5/8")



MODELO

AÑOS

Land Rover, Range Rover

83-99

MOTOR

V8

TC N/R TRACC T OEM 1043-226-037 4 VEL

Mazda

FC-6T70

6F50N / 6F55



MODELO

AÑOS

Mazda 6

09-10

MOTOR

V6

TC N/R TRACC D OEM 7T4Z-7A098-B 6 VEL

FC-E4N71B

E4N71B, N4A3L



MODELO

AÑOS

Mazda 929, Miata, RX-7

88-97

MOTOR

L4, V6

TC 14 TRACC T OEM BV01-19-815 4 VEL

1.4 Filtro y empaque de transmisión automática

Automatic transmission filter kits



Mazda

FC-F3AE
F3A / MX1



MODELO					AÑOS		
Mazda 323					88-89		
					MOTOR		
					L4		
TC	18	TRACC	D	OEM	FT21-19-815D	3	VEL

FC-F3AM
F3A / MX1

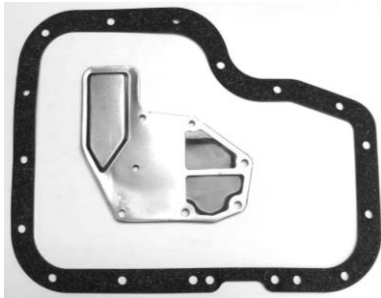

MODELO					AÑOS		
Mazda 323, 626, GLC					81-87		
					MOTOR		
					L4		
TC	18	TRACC	D	OEM	FT01-19-815	3	VEL

FC-FNR5
FNR5 / FS5A-EL



MODELO					AÑOS		
Mazda 3, Mazda 5, Mazda 6					05-11		
					MOTOR		
					L4		
TC	20	TRACC	D	OEM	FNC1-21-500	5	VEL

FC-FW6AEL
FW6AEL



MODELO					AÑOS		
Mazda CX-5 2.0L, 2.2L, 2.5L, Mazda 3 2.0L, 2.2L					11-17		
					MOTOR		
					L4		
TC	16	TRACC	D	OEM	FZ01-21-500	6	VEL

FC-G4AHL
G4A-HL
(1.250" ALTO)

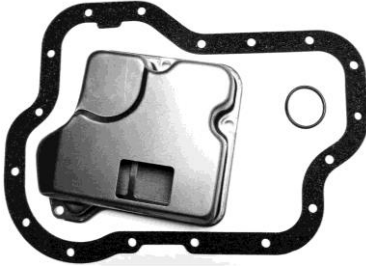

MODELO					AÑOS		
Mazda 323					88-92		
					MOTOR		
					L4		
TC	17	TRACC	D	OEM	FU50-21-500A	4	VEL

FC-GF4AEL
GF4AEL
(Filtro de 1" de alto)

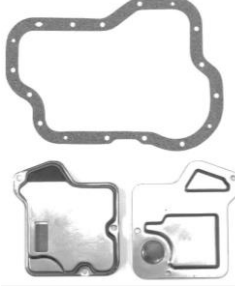

MODELO					AÑOS		
Mazda 323, 626, Ford Probe					88-92		
					MOTOR		
					L4		
TC	17	TRACC	D	OEM	FU31-21-500	4	VEL

1.4 Filtro y empaque de transmisión automática

Automatic transmission filter kits



Mazda

FC-JF403N

JF403E / L J4A-EL



MODELO

AÑOS

Mazda Millenia

95-02

MOTOR

V6

TC 22 TRACC D OEM FX01-19-815 4 VEL

FC-JF506E

JF506E / JA5A-EL



MODELO

AÑOS

Mazda 6S, MPV

02-06

MOTOR

V6

TC 20 TRACC D OEM FP01-21-500 5 VEL

FC-L4N71B

L4N71B (4WD)



MODELO

AÑOS

Mazda B2600, MPV, RX7

86-89

MOTOR

L4

TC 14 TRACC T OEM BT40-19-815A 4 VEL

FC-R4AEL

R4A-EL

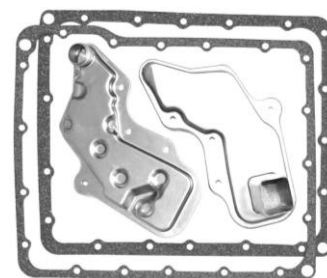

MODELO

AÑOS

Mazda 929, MPV, RX7

89-99

MOTOR

Rotary, V6

TC 20 TRACC T OEM BV92-19-815 4 VEL

FC-TF81SC

AWTF81SC / AF21B



MODELO

AÑOS

Mazda 6S, CX7, CX9

06-08

MOTOR

L4, V6

TC TRACC D/AWD OEM 60-27-0F099-0080 6 VEL

1.4 Filtro y empaque de transmisión automática

Automatic transmission filter kits



Mercedes Benz



MODELO							AÑOS	
A140, A160, A180							97-04	
							MOTOR	
							L4	
TC	NR	TRACC	T	OEM	168-377-0395	5	VEL	

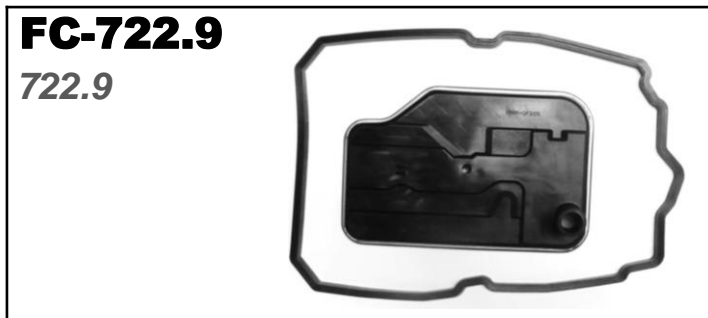

MODELO							AÑOS	
C230, C280, C300, C350, C63 AMG, CL500, CL550, CL63 AMG, CLK350, CLK500, CLK550							06-09	
							MOTOR	
							V6, V8	
TC	NR	TRACC	T	OEM	220-277-0395	7	VEL	



MODELO							AÑOS	
220, 230, 240D, 280E, 300D, 300SEL, 450E, 450SEL, 450SLC							69-83	
							MOTOR	
							L4, L6, V8	
TC	NR	TRACC	T	OEM	115-270-03-98	3/4	VEL	



MODELO							AÑOS	
220, 230, 240D, 280E, 300D, 300SEL, 450E, 450SEL, 450SLC							72-80	
							MOTOR	
							L4, L6, V8	
TC	NR	TRACC	T	OEM	123-270-00-98	3/4	VEL	



MODELO							AÑOS	
Mercedes Benz 190D, 190E, C class							84-97	
							MOTOR	
							L4, L5, L6	
TC	NR	TRACC	T	OEM	126-277-02-95	4	VEL	



MODELO							AÑOS	
Mercedes Benz C class, E class							83-97	
							MOTOR	
							L5, L6, V8	
TC	NR	TRACC	T	OEM	126-277-02-95	4	VEL	

1.4 Filtro y empaque de transmisión automática

Automatic transmission filter kits



Mercedes Benz

FC-W4B025

722.1 / 722.2
(con cuello de 1")



MODELO					AÑOS		
220, 230, 240D, 280E, 300D, 300SEL, 450E, 450SEL, 450SLC					72-80		
					MOTOR		
					L4, L6, V8		
TC	NR	TRACC	T	OEM	109-270-02-98	3/4	VEL

FC-W5A030

722.5



MODELO					AÑOS		
300SL, S320, SL320					94-97		
					MOTOR		
					L6		
TC	NR	TRACC	T	OEM	129-277-00-95	5	VEL

FC-W5A580

W5A580/722.6



MODELO					AÑOS		
Sprinter Van, C, CL, CLK Class, E Class, E Class Wagon, ML320, ML-430, S, SL					97-09		
					MOTOR		
					Todos		
TC	NR	TRACC	T	OEM	140-277-0095	5	VEL

Mini Cooper

FC-355

GA6F21WA
(cuello de 1" de altura)



MODELO					AÑOS		
Mini Cooper S (R52/R53)					04-08		
					MOTOR		
					L4		
TC	8	TRACC	D/AWD	OEM		6	VEL

FC-356

GA6F21WA
(cuello de 3/4" de altura)



MODELO					AÑOS		
Mini Cooper (07-15), Cooper Countryman, Cooper Paceman 1.6L (14-16)					14-16		
					MOTOR		
					L4		
TC	8	TRACC	D/AWD	OEM		6	VEL

1.4 Filtro y empaque de transmisión automática

Automatic transmission filter kits



Mini Cooper

FC-357
VT2

NUEVO PRODUCTO

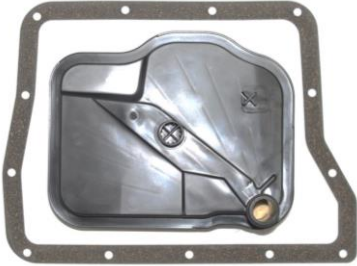

MODELO					AÑOS	
Mini Cooper 1.4L, 1.6L					02-09	
					MOTOR	
					L4	
TC	13	TRACC	D	OEM	CVT	VEL

FC-358
GACVT16Z

NUEVO PRODUCTO



MODELO					AÑOS	
Mini Cooper 1.4L, 1.6L					02-08	
					MOTOR	
					L4	
TC	13	TRACC	D	OEM	CVT	VEL

Mitsubishi

FC-351
DCT470

NUEVO PRODUCTO



MODELO					AÑOS	
Lancer Evolution 2.0L Outlander 2.4L					08-15	
					MOTOR	
					L4	
TC	N/R	TRACC	AWD	OEM	6	VEL

FC-F1C1
F1C1



MODELO					AÑOS		
Lancer, Colt					02-11		
					MOTOR		
					L4		
TC	15	TRACC	D	OEM	MR515064	6	VEL

FC-F4A33
F4A32 / F4A33
W4A32 / W4A33



MODELO					AÑOS		
Diamante, 3000 GT, Eclipse, Galant					91-00		
					MOTOR		
					L4, V6		
TC	14	TRACC	D	OEM	MD735572 D	4	VEL

FC-F4A411CA
F4A41-1, F4A42-1



MODELO					AÑOS		
Diamante, Eclipse, Galant, Mirage					97-12		
					MOTOR		
					L4		
TC	NR	TRACC	D	OEM	MD752072	4 y 5	VEL

1.4 Filtro y empaque de transmisión automática

Automatic transmission filter kits



Mitsubishi

FC-F4A41A

F4A41 / F4A42



MODELO

AÑOS

Mitsubishi Eclipse, Galant,
Mirage

97-06

MOTOR

L4, V6

TC 15 TRACC D OEM MD758691 4 VEL

FC-F4A51A

F4A51



MODELO

AÑOS

Mitsubishi Diamante

96-99

MOTOR

V6

TC 15 TRACC D OEM MD758684 4 VEL

FC-F4A51D

F4A51



MODELO

AÑOS

Galant, Eclipse GS, GT, Endeavor

99-11

MOTOR

L4, V6

TC 15 TRACC D OEM MR350441 4 VEL

FC-F4A51T

F4A41 / 42

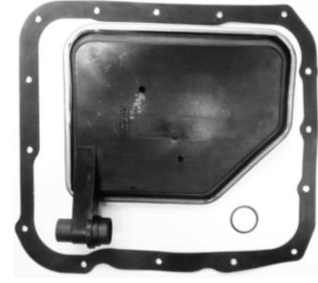

MODELO

AÑOS

Montero Limited
Outlander

01-04

MOTOR

L4-L6

TC 15 TRACC T OEM 46321-39010 5 VEL

FC-KM171

KM171, KM172,
KM-170-2

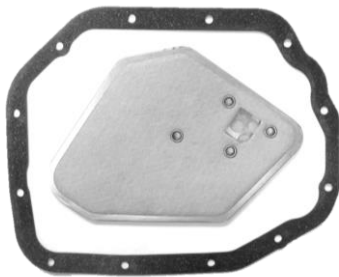

MODELO

AÑOS

Galant, Dodge Colt

82-87

MOTOR

L4, V6

TC 12 TRACC D OEM MD707786 4 VEL

FC-KM175

KM175,
KM176-5

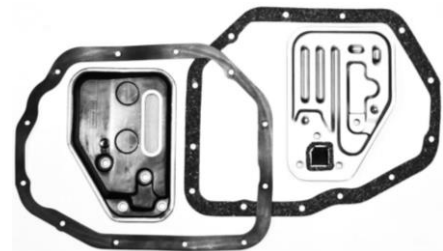

MODELO

AÑOS

Galant Dodge Colt

87-95

MOTOR

L4, V6

TC 12/13 TRACC D OEM MD673110 4 VEL

1.4 Filtro y empaque de transmisión automática

Automatic transmission filter kits



Mitsubishi

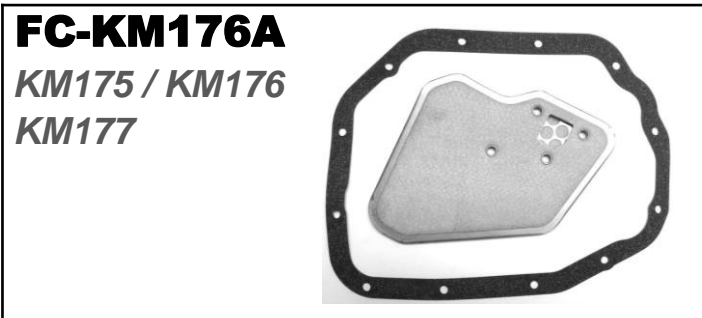

MODELO					AÑOS		
Mitsubishi Cordia, Galant					84-91		
					MOTOR		
					L4, V6		
TC	12	TRACC	D	OEM	MD729955	4	VEL

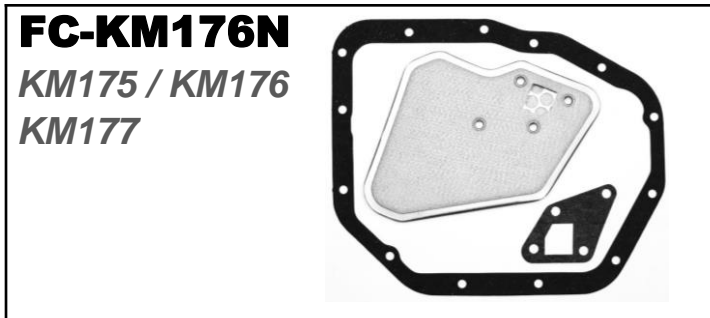

MODELO					AÑOS		
Mitsubishi Galant, Sigma, Sonata					87-93		
					MOTOR		
					L4, V6		
TC	13	TRACC	D	OEM	MD729955	4	VEL

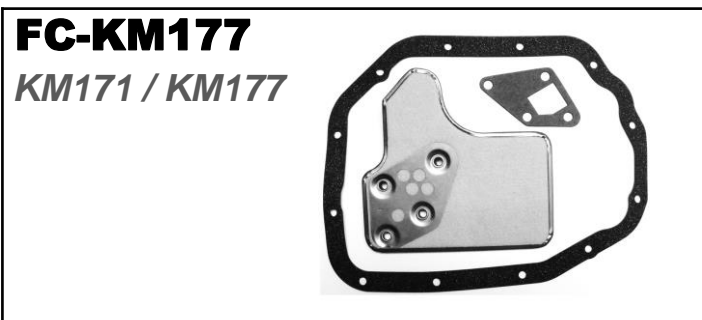

MODELO					AÑOS		
Mitsubishi Eclipse, Expo LRV, Galant, Mirage, Sigma					87-92		
					MOTOR		
					L4		
TC	12	TRACC	D	OEM	MD729954	4	VEL

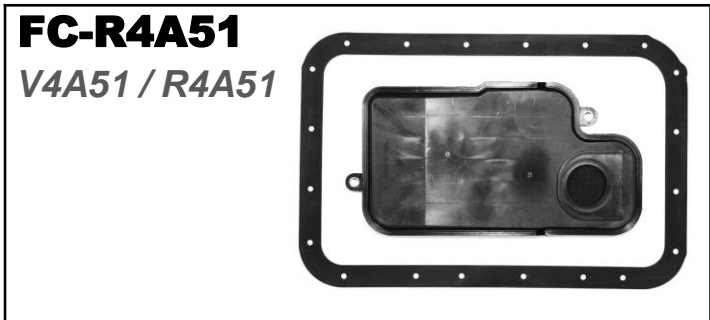

MODELO					AÑOS		
Mitsubishi Montero, Montero Sport (sin cuello)					98-06		
					MOTOR		
					V6		
TC	20	TRACC	T	OEM	MR357710	4	VEL



MODELO					AÑOS		
Montero Sport (con cuello)					98-06		
					MOTOR		
					V6		
TC	19	TRACC	4WD	OEM	MR528836	4	VEL

1.4 Filtro y empaque de transmisión automática

Automatic transmission filter kits



Nissan

FC-323

JF010E / RE0F09A



MODELO

AÑOS

Murano

03-12

MOTOR

V6

TC 22 TRACC D OEM CVT VEL

FC-324

RE0F08A



MODELO

AÑOS

Versa 1.8L
Tiida 1.8L

06-19

MOTOR

L4

TC 21 TRACC D OEM CVT VEL

FC-325

JF015E



MODELO

AÑOS

Versa, Note, Juke, March, Tiida 1.6L,
Sentra 1.8L

12-19

MOTOR

L4

TC N/R TRACC D OEM CVT VEL

FC-326

JF015E

Filtro secundario



MODELO

AÑOS

Versa, Note, Juke, March, Tiida 1.6L,
Sentra 1.8L

12-19

MOTOR

L4

TC N/R TRACC D OEM CVT VEL

FC-327

RE5R05A



MODELO

AÑOS

Pathfinder V6 4.0L, Armada,
Titan V8 5.6L, Frontier V6 4.0L

04-13

MOTOR

V6,V8

TC N/R TRACC T OEM 5 VEL

FC-328

RE0F08A

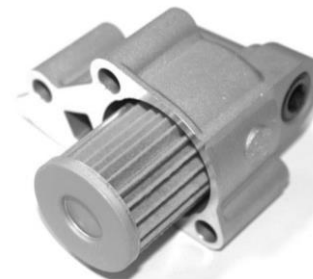

MODELO

AÑOS

Versa 1.8L,
Tiida 1.8L

06-19

MOTOR

L4

TC N/R TRACC D OEM CVT VEL

1.4 Filtro y empaque de transmisión automática

Automatic transmission filter kits



Nissan

FC-3N71A
JATCO 3N71B



MODELO						AÑOS	
Datsun 210, Pick Ups 620 - 720						72-86	
						MOTOR	
						L4	
TC	17	TRACC	T	OEM	31728-X0100	3	VEL

FC-4F02A
RL-4F02A
RE4F02A



MODELO						AÑOS	
Maxima, Pulsar NX, Stanza						85-94	
						MOTOR	
						V6	
TC	17	TRACC	D	OEM	31728-21X01	4	VEL

FC-4F04A
RE4F04A, 4F20E



MODELO						AÑOS	
Nissan Altima, Maxima, Quest / Mercury Villager						93-02	
						MOTOR	
						L4, V6	
TC	21	TRACC	D	OEM	31728-80X03	4	VEL

FC-4F04AN
4F04AN



MODELO						AÑOS	
Nissan Altima, Maxima, Quest						02-06	
						MOTOR	
						L4, V6	
TC	21	TRACC	D	OEM	31397-80X01	4	VEL

FC-4R01A2W



MODELO						AÑOS	
Pathfinder, Pick Ups (2WD)						90-99	
						MOTOR	
						V6	
TC	20	TRACC	T	OEM	31728-41X00	4	VEL

FC-4R01A4W
RE4R10A
RG4R01A
JR403E

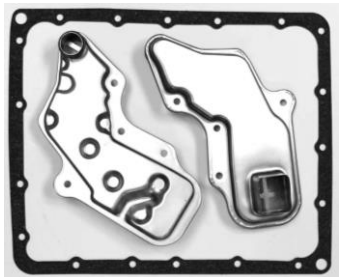

MODELO						AÑOS	
Pathfinder, Pick Ups, (4WD), Camionetas 2WD, 4WD						90-99	
						MOTOR	
						L4, V6	
TC	20	TRACC	T	OEM	31728-41X01	4	VEL

1.4 Filtro y empaque de transmisión automática

Automatic transmission filter kits



Nissan

FC-4R01AP

RL-4R01A



MODELO

AÑOS

Frontier 2WD, 4WD, Frontier,
Pick Ups (2WD)

90-97

MOTOR

L4, V6

TC 20 TRACC T OEM 31728-48X00 4 VEL

FC-AW55

AW55-50SN



MODELO

AÑOS

Nissan Altima, Maxima, Quest

04-08

MOTOR

V6

TC NR TRACC D OEM 24220578 5 VEL

FC-CVTC

RE0F10A (CVT)



MODELO

AÑOS

Nissan Sentra, Altima,
Versa, Nissan Rogue (filtro externo)

05-16

MOTOR

L4 / V6

TC NR TRACC D OEM 31728-29X0A CVT VEL

FC-DPO

DPO



MODELO

AÑOS

Platina

02-10

MOTOR

L4

TC N/R TRACC D OEM 7701-467-106 4 VEL

FC-JATCO

JATCO L-4N71B



MODELO

AÑOS

Datsun 210, 510,
Pick ups (2WD), Pathfinder

79-87

MOTOR

L4, V6

TC 14 TRACC T OEM 31728-X8600 4 VEL

FC-JF010E

CVT RE0F09A

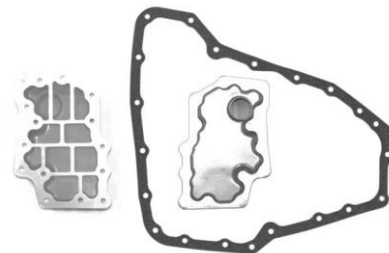

MODELO

AÑOS

Nissan Murano

03-09

MOTOR

V6

TC 21 TRACC D/AWD OEM N / D CVT VEL

1.4 Filtro y empaque de transmisión automática

Automatic transmission filter kits



Nissan

FC-JF011E
RE0F10A (CVT)



MODELO							AÑOS	
Nissan Sentra , Versa , Rogue, filtro con cuello alto (26.8mm)							05-16	
							MOTOR	
							L4	
TC	20	TRACC	D	OEM	31728-1XZOA	CVT	VEL	

FC-JF017E
JF017E



MODELO							AÑOS	
Nissan Murano V6 3.5L Pathfinder V6 3.5L X-Trail 2.5L							13-15	
							MOTOR	
							L4 / V6	
TC	21	TRACC	D	OEM	31728-29XOA	CVT	VEL	

FC-JR503E
RE5R01A



MODELO							AÑOS	
Infinity Q45, Nissan 300ZX							90-01	
							MOTOR	
							V8	
TC	20	TRACC	T	OEM	31728-60X01	5	VEL	

FC-R4AEL
RE4R01A (4WD)



MODELO							AÑOS	
Xterra SE (4WD)							00-04	
							MOTOR	
							L4, V6	
TC	20	TRACC	T	OEM	31728-41X01	4	VEL	

FC-RE0F10A
CVT RE0F10A



MODELO							AÑOS	
Nissan Altima (07-09),Maxima (07-09), Versa (07-10),Sentra (07-08), Rogue (07-08), trans. CVT RE0F10A							07-10	
							MOTOR	
							L4, V6	
TC	20	TRACC	D	OEM	31728-1XZOA	CVT	VEL	

FC-RE4F03V
RE4F03V



MODELO							AÑOS	
Nissan Tiida							08-12	
							MOTOR	
							L4	
TC	21	TRACC	D	OEM	31728-85X01	4	VEL	

1.4 Filtro y empaque de transmisión automática

Automatic transmission filter kits



Nissan

FC-RE4F04B

RE4F04A / B



MODELO

AÑOS

Altima, Maxima, Quest

02-06

MOTOR

L4, V6

TC	21	TRACC	D	OEM	31728-85X01	4	VEL
----	----	-------	---	-----	-------------	---	-----

FC-RE4R03A

RE4R03A



MODELO

AÑOS

240SX, 300ZX, Frontier, Xterra (2WD)

89-04

MOTOR

V8

TC	20	TRACC	T	OEM	31728-51X02	4	VEL
----	----	-------	---	-----	-------------	---	-----

FC-RE5R05A

RE5R05A



MODELO

AÑOS

Nissan 350Z, Frontier, Armada, Titan,
Pathfinder, Xterra XE

03-09

MOTOR

L4, V6, V8

TC	24	TRACC	T	OEM	31728-97X00	5	VEL
----	----	-------	---	-----	-------------	---	-----

FC-RE7R01A

RE7R01A

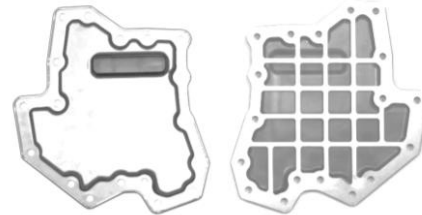

MODELO

AÑOS

Nissan 370Z (09-14),
Infiniti G35 (08-14),
trans., 7 vel.

08-14

MOTOR

V6

TC	N / R	TRACC	T	OEM	N / D	7	VEL
----	-------	-------	---	-----	-------	---	-----

FC-RL3F01A

RL3F01A,
RN3F01A



MODELO

AÑOS

Sentra, Pulsar
(carter profundo)

87-92

MOTOR

L4

TC	14	TRACC	D	OEM	31728-01X10	3	VEL
----	----	-------	---	-----	-------------	---	-----

FC-RN3F01A

RN3F01A

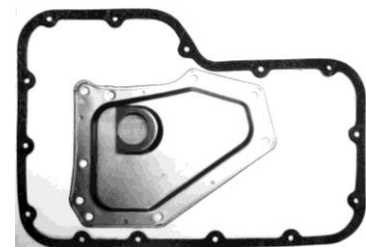

MODELO

AÑOS

Pulsar, Tsuru II, Sentra, Stanza

82-86

MOTOR

L4

TC	14	TRACC	D	OEM	31728-01X08	3	VEL
----	----	-------	---	-----	-------------	---	-----

1.4 Filtro y empaque de transmisión automática

Automatic transmission filter kits



Nissan

FC-SENTRA

RL-4F03A



MODELO					AÑOS		
Tsuru III, Sentra, 200SX					94-06		
					MOTOR		
					L4		
TC	21	TRACC	D	OEM	31728-31X01	4	VEL

FC-TSURU

RN/RL 3F01A



MODELO					AÑOS		
Tsuru I, II, III y Sentra					84-94		
					MOTOR		
					L4		
TC	14	TRACC	D	OEM	31728-01X09	3	VEL

Peugeot

FC-DPO

DPO / AL-4



MODELO					AÑOS		
206, 406, 407					99-07		
					MOTOR		
					L4		
TC	N/R	TRACC	D	OEM	7701-467-106	4	VEL

FC-TF81SC

AWTF81SC / AF21B



MODELO					AÑOS		
Peugeot 307					06-08		
					MOTOR		
					L4, V6		
TC	N/R	TRACC	D	OEM	60-27-0F099-0080	6	VEL

FC-ZF3HP22

ZF3HP22

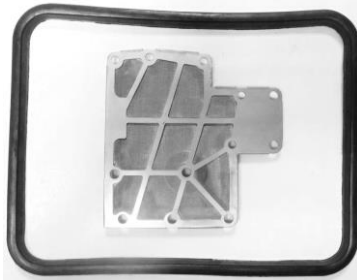

MODELO					AÑOS		
Peugeot					75-86		
					MOTOR		
					L4		
TC	N/R	TRACC	T	OEM	24231-209-747	3	VEL

1.4 Filtro y empaque de transmisión automática

Automatic transmission filter kits



Renault

FC-DPO

DPO / AL-4



MODELO					AÑOS		
Clio, Scenic, Laguna					02-06		
					MOTOR		
					L4		
TC	N/R	TRACC	D	OEM	7701-467-106	4	VEL

FC-M101

MB1 / MJ1 / MJ3



MODELO					AÑOS		
Alliance, Encore					84-86		
					MOTOR		
					L4		
TC	N/R	TRACC	D	OEM	77-00-739-883	3	VEL

FC-MJ3

MB1 / MJ1 / MJ3



MODELO					AÑOS		
Alliance, Encore					82-85		
					MOTOR		
					L4		
TC		TRACC	D	OEM	T0727392	3	VEL

Saab

FC-AW50

AW50-42LE



MODELO					AÑOS		
900, 900S, 9-2X, 9-3					94-07		
					MOTOR		
					L4		
TC	N/R	TRACC	D/AWD	OEM	30681088	4	VEL

FC-ZF4HP14

ZF4HP14



MODELO					AÑOS		
9000S (sin turbo)					94-98		
					MOTOR		
					L4		
TC	N/R	TRACC	D	OEM	1036-226-013	4	VEL

1.4 Filtro y empaque de transmisión automática

Automatic transmission filter kits



Saab

FC-ZF4HP18

ZF4HP18Q



MODELO						AÑOS	
9000, 9000S (con turbo)						94-98	
						MOTOR	
TC	N/R	TRACC	D	OEM	7599525	4	VEL

Subaru

FC-353

5EAT



MODELO						AÑOS	
Legacy 2.5L, 3.0L, 3.6L, Impreza 2.5L, Outback 3.0L, 3.6L Tribeca 3.6L						07-14	
						MOTOR	
TC	21	TRACC	AWD	OEM		5	VEL

FC-354

4EAT



MODELO						AÑOS	
Legacy 2.5L, Outback 2.5L, Impreza 2.5L, Forester 2.5L						05-13	
						MOTOR	
TC	N/R	TRACC	AWD	OEM		4	VEL

FC-4EATCA

4EAT / R4AXEL



MODELO						AÑOS	
Subaru Baja, Legacy, Forester, Outback						98-04	
						MOTOR	
TC		TRACC	D	OEM	38325-AA032	4	VEL

FC-4EATS

4EAT / R4AXEL



MODELO						AÑOS	
Subaru Baja, Legacy, Forester, Outback						98-04	
						MOTOR	
TC	20	TRACC	D	OEM	31728-AA050	4	VEL

1.4 Filtro y empaque de transmisión automática

Automatic transmission filter kits



Subaru

FC-ECVT

ECVT



MODELO							AÑOS	
Subaru Justy							89-94	
							MOTOR	
							L3	
TC	13	TRACC	D	OEM	31728-KA031	CVT	VEL	

FC-M41

M41

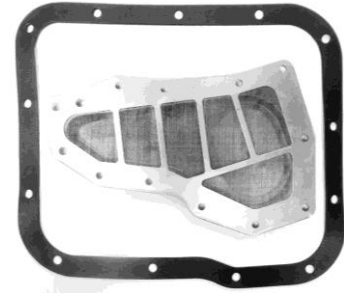

MODELO							AÑOS	
Subaru DL, GF							75-82	
							MOTOR	
							H4	
TC	13	TRACC	T	OEM	31728-X0F00	3	VEL	

FC-M41A

M41A



MODELO							AÑOS	
DL, GF, GL, GL-10, RX, LOYALE, XT, XT6, BAJA							83-89	
							MOTOR	
							H4	
TC	14	TRACC	T	OEM	31728-X0100	3	VEL	

FC-R4AXELA

R4AX-EL



MODELO							AÑOS	
Loyale, XT Coupe, XTGL, Station Wagon, Impreza							87-94	
							MOTOR	
							H4, H6	
TC	20	TRACC	T	OEM	31728-AA000	4	VEL	

FC-R4AXELN

R4AX-EL



MODELO							AÑOS	
Impreza, Legacy, SVX, Forester							93-99	
							MOTOR	
							H4, H6	
TC	20	TRACC	T	OEM	31728-AA011	4	VEL	

1.4 Filtro y empaque de transmisión automática

Automatic transmission filter kits



Suzuki

FC-352
CVT7

NUEVO PRODUCTO

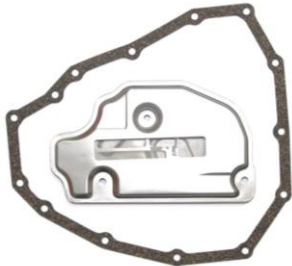

MODELO					AÑOS		
Swift 1.4L					12-15		
					MOTOR		
					L4		
TC	14	TRACC	D/AWD	OEM		CVT	VEL

FC-A43DE
A43DE , A44DE



MODELO					AÑOS		
Suzuki Vitara, Grand Vitara					99-04		
					MOTOR		
					Todos		
TC	14	TRACC	T	OEM	26582-57800	4	VEL

FC-AW50
AW50-42LE



MODELO					AÑOS		
Aerio					04-07		
					MOTOR		
					L4		
TC	N/R	TRACC	D/AWD	OEM	30681088	4	VEL

Toyota

FC-A141E
A141E

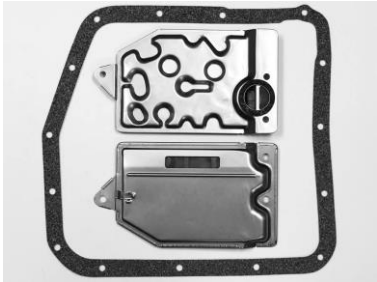

MODELO					AÑOS		
Camry					92-01		
					MOTOR		
					L4		
TC	15	TRACC	D	OEM	35330-32022	4	VEL

FC-A141L
A141L, A140E,
A140L

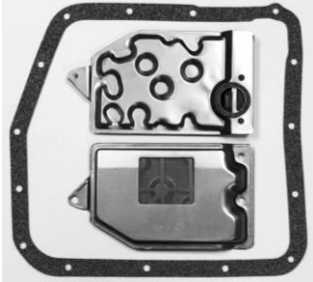

MODELO					AÑOS		
Camry, Corolla, Tercel					83-99		
					MOTOR		
					L4		
TC	15	TRACC	D	OEM	35330-20H00	4,3	VEL

1.4 Filtro y empaque de transmisión automática

Automatic transmission filter kits



Toyota

FC-340
K112

NUEVO PRODUCTO



MODELO					AÑOS	
RAV4					04-17	
					MOTOR	
					L4	
TC	19	TRACC	AWD	OEM	CVT	VEL

FC-341
K311

NUEVO PRODUCTO



MODELO					AÑOS	
Corolla 1.5L ZZE141					01-12	
					MOTOR	
					L4	
TC	16	TRACC	D	OEM	CVT	VEL

FC-342
AB60E/F

NUEVO PRODUCTO



MODELO					AÑOS	
Land Cruiser, Sequioa 5.7L, Tundra 4.0L, 5.7L					07-14	
					MOTOR	
					V6, V8	
TC	12	TRACC	T/4WD	OEM	6	VEL

FC-343
A341E

NUEVO PRODUCTO



MODELO					AÑOS	
Hiace (KDH222)					00-12	
					MOTOR	
					L4	
TC	N/R	TRACC	T	OEM	4	VEL

FC-344
AC60F

NUEVO PRODUCTO



MODELO					AÑOS	
Hiace 2.7L					13-18	
					MOTOR	
					L4	
TC	10	TRACC	T	OEM	6	VEL

FC-345
K313

NUEVO PRODUCTO



MODELO					AÑOS	
Corolla 1.6L, 1.8L					13-19	
					MOTOR	
					L4	
TC	16	TRACC	D	OEM	CVT	VEL

1.4 Filtro y empaque de transmisión automática

Automatic transmission filter kits



Toyota

FC-359
U760E

NUEVO PRODUCTO



MODELO					AÑOS	
Camry 2.5L, RAV4 2.5L, Sienna, Highlander 2.7L					13-17	
					MOTOR	
					L4	
TC	19	TRACC	D	OEM	6	VEL

FC-360
U541E

NUEVO PRODUCTO



MODELO					AÑOS	
Avanza 1.5L					16-19	
					MOTOR	
					L4	
TC	18	TRACC	D	OEM	4	VEL

FC-361
CW6A

NUEVO PRODUCTO



MODELO					AÑOS	
Toyota Yaris 1.5L, Mazda 2 1.5L, Mazda 3 2.0L, 2.5L, Mazda CX5 2.0L, 2.5L					14-18	
					MOTOR	
					L4	
TC	16	TRACC	D/AWD	OEM	6	VEL

FC-A240E
A240E, A242L

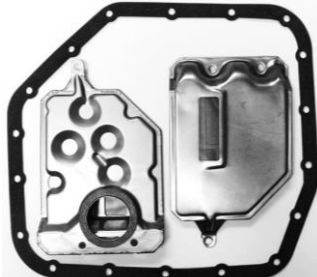

MODELO					AÑOS		
Camry, Corolla, Tercel					83-88		
					MOTOR		
					L4		
TC	18	TRACC	D	OEM	35330-12011	4	VEL

FC-A245E
A245E

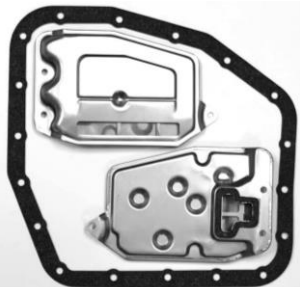

MODELO					AÑOS		
Corolla, RAV 4					93-03		
					MOTOR		
					L4		
TC	18	TRACC	D	OEM	35330-12040	4	VEL

FC-A246E
A246E

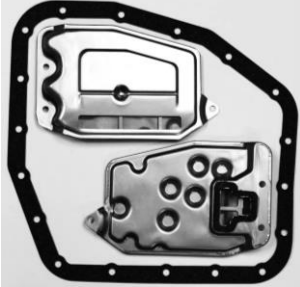

MODELO					AÑOS		
Corolla, Matrix					03-06		
					MOTOR		
					L4		
TC	18	TRACC	D	OEM	35330-12040	4	VEL

1.4 Filtro y empaque de transmisión automática

Automatic transmission filter kits



Toyota

FC-A30

A30



MODELO				AÑOS			
Carina, Celica, Corolla, Corona, Crown, Mark II, Land Cruiser, Pick ups				70-78			
				MOTOR			
				L4, L6			
TC	16	TRACC	T	OEM	35303-30013	4	VEL

FC-A340

A340

(CUELLO DE 3/4" DE ALTO)

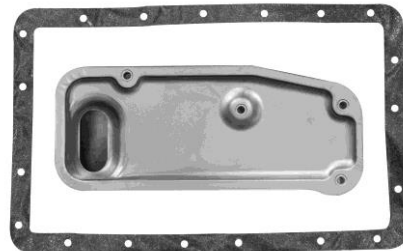

MODELO				AÑOS			
4 Runner, Landcruiser, Pick up T100, Tacoma				95-00			
				MOTOR			
				L4, V6			
TC	20	TRACC	T	OEM	35330-22010	4	VEL

FC-A340E

A340E

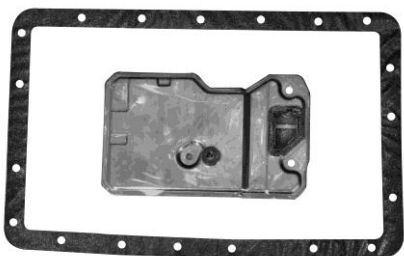

MODELO				AÑOS			
Pick Up, T100, Tacoma (2WD), 4Runner				85-99			
				MOTOR			
				V6			
TC	19	TRACC	T	OEM	35330-30011	4	VEL

FC-A340F

A340F

(CUELLO DE 3/8" DE ALTO)

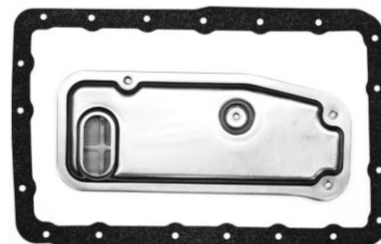

MODELO				AÑOS			
T100, Tacoma (4WD)				95-97			
				MOTOR			
				4, 6			
TC	19	TRACC	4WD	OEM	35330-60020	4	VEL

FC-A340F4

A340F

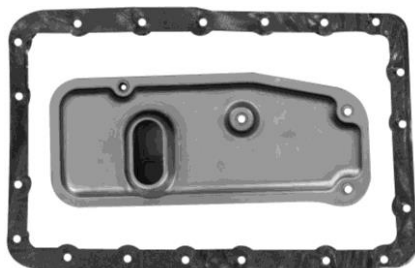

MODELO				AÑOS			
4 Runner (4WD), Pick up				96-97			
				MOTOR			
				V6			
TC	19	TRACC	T	OEM	35330-35020	4	VEL

FC-A340H

A340H

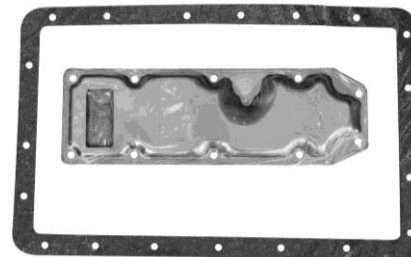

MODELO				AÑOS			
4 Runner, Pick up T100, Mitsubishi Montero				85-00			
				MOTOR			
				L4, V6			
TC	19	TRACC	4WD	OEM	35303-35010	4	VEL

1.4 Filtro y empaque de transmisión automática

Automatic transmission filter kits



Toyota

FC-A341E
A341E

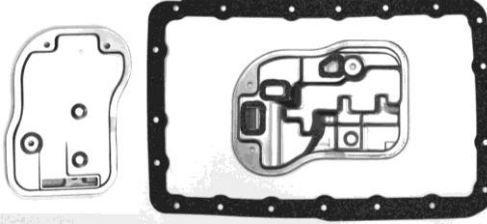

MODELO						AÑOS	
4Runner, Tundra (2WD)						00-03	
						MOTOR	
						L6, V8	
TC	19	TRACC	T	OEM	35330-30020	4	VEL

FC-A343F
A343F

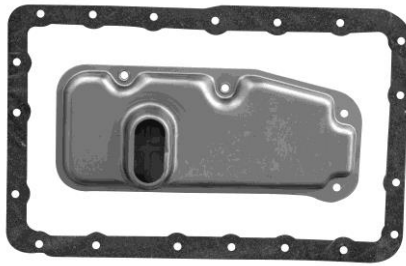

MODELO						AÑOS	
4Runner, Landcruiser, Sequoia, Tacoma, Tundra						98-12	
						MOTOR	
						V6, V8	
TC	19	TRACC	T	OEM	35330-60030	4	VEL

FC-A350E
A350E

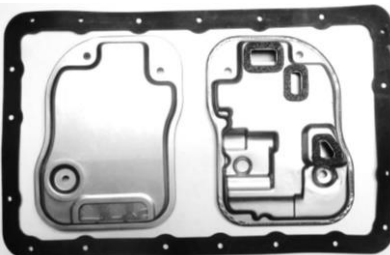

MODELO						AÑOS	
Lexus GS300						94-95	
						MOTOR	
						L4, V6	
TC	19	TRACC	T	OEM	35330-30040	4	VEL

FC-A40D
A40D, A41D

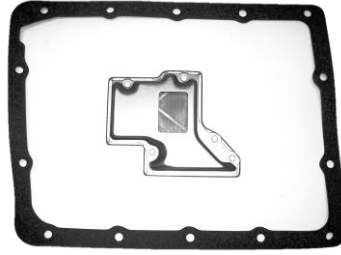

MODELO						AÑOS	
Celica, Corona, Corolla, Supra						77-85	
						MOTOR	
						L4	
TC	14	TRACC	T	OEM	35303-30031	3	VEL

FC-A41
A41, A40



MODELO						AÑOS	
Celica, Corolla, Corona, Pick up Hilux						73-81	
						MOTOR	
						L4	
TC	14	TRACC	T	OEM	35303-22020	3	VEL

FC-A42DL
A42DL

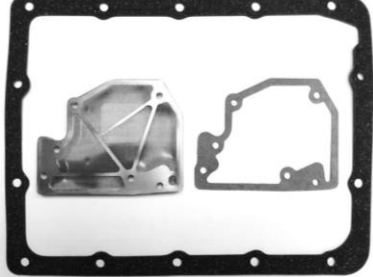

MODELO						AÑOS	
Corolla, 4Runner, Land Cruiser, Pick ups						82-87	
						MOTOR	
						L4, L6	
TC	14	TRACC	T	OEM	35303-14010	4	VEL

1.4 Filtro y empaque de transmisión automática

Automatic transmission filter kits



Toyota

FC-A43D

A43D

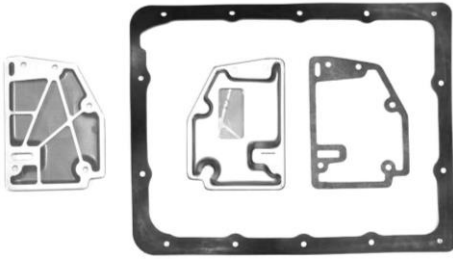

MODELO					AÑOS		
4Runner, Pick ups, Tacoma					84-01		
					MOTOR		
					L4		
TC	14	TRACC	T	OEM	35303-30050	4	VEL

FC-A43DE

A43DE



MODELO					AÑOS		
4Runner, Pick ups, Previa					81-97		
					MOTOR		
					L4, L6		
TC	14	TRACC	T	OEM	35303-33060	4	VEL

FC-A440F

A440F

(5/8" de alto)

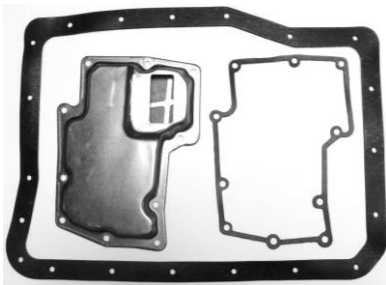

MODELO					AÑOS		
Landcruiser (2WD)					85-92		
					MOTOR		
					L4, L6		
TC	20	TRACC	T	OEM	35330-60011	4	VEL

FC-A440FD

A440F

(PROFUNDO)

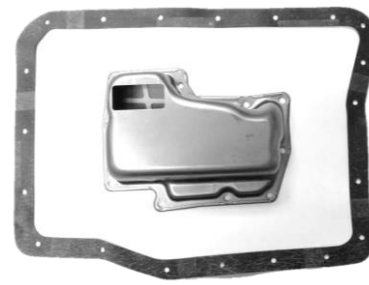

MODELO					AÑOS		
Toyota Land Cruiser (4WD)					85-92		
					MOTOR		
					L4, L6		
TC	20	TRACC	T	OEM	35303-60011	4	VEL

FC-A46DE

A43DE / A46DE



MODELO					AÑOS		
Tacoma					02-04		
					MOTOR		
					L4		
TC	14	TRACC	T	OEM	35303-35020	4	VEL

FC-A4LB1

A4LB1



MODELO					AÑOS		
Toyota Avanza					03-15		
					MOTOR		
					L4		
TC	14	TRACC	T	OEM	35303-97501	4	VEL

1.4 Filtro y empaque de transmisión automática

Automatic transmission filter kits



Toyota

FC-AC60F
AC60F



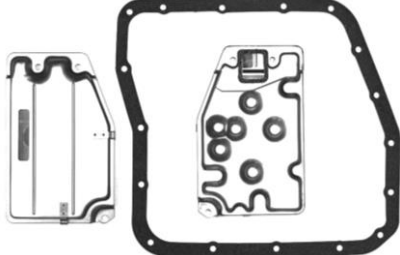

MODELO							AÑOS	
Toyota Tacoma 2.7L, 3.5L							16-18	
							MOTOR	
							V6	
TC	10	TRACC	T	OEM	35330-71010	6	VEL	

FC-A540E
A540E, A540H

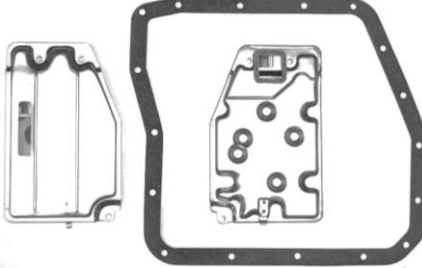

MODELO							AÑOS	
Camry, RAV 4, Sienna							88-00	
							MOTOR	
							L4, V6	
TC	17	TRACC	D	OEM	35330-32031	4	VEL	

FC-A541E
A541E



MODELO							AÑOS	
Camry, Sienna, Solara							94-06	
							MOTOR	
							V6	
TC	17	TRACC	D	OEM	35330-33030	4	VEL	

FC-A55F
A55F



MODELO							AÑOS	
Terrel (2WD)							79-88	
							MOTOR	
							L4	
TC	17	TRACC	D	OEM	35303-16020	3	VEL	

FC-A55F4
A55F

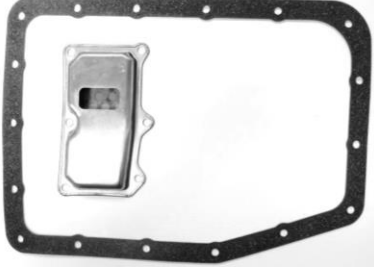

MODELO							AÑOS	
Terrel (4WD)							84-87	
							MOTOR	
							L4	
TC	17	TRACC	D	OEM	35303-16030	3	VEL	

FC-A650E
A650E

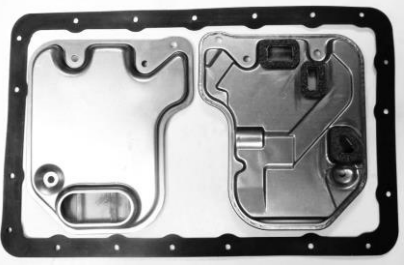

MODELO							AÑOS	
Lexus ES300, GS300, GS430, IS300, SC430							98-05	
							MOTOR	
							L6, V8	
TC	18	TRACC	T	OEM	35330-30070	5	VEL	

1.4 Filtro y empaque de transmisión automática

Automatic transmission filter kits



Toyota

FC-A750E

A750E / A750F



MODELO

AÑOS

Toyota 4Runner, Land Cruiser, Tacoma, Tundra, FJ Cruiser, Sequoia (2WD)

03-09

MOTOR

V6, V8

TC 20 TRACC T OEM 35330-60050 5 VEL

FC-A750F

A442F



MODELO

AÑOS

4Runner, FJ Cruiser, Sequoia, Tacoma, Tundra (4WD)

03-09

MOTOR

L6

TC 20 TRACC T OEM 35330-60010 4 VEL

FC-U140E

U140E/F
U240E

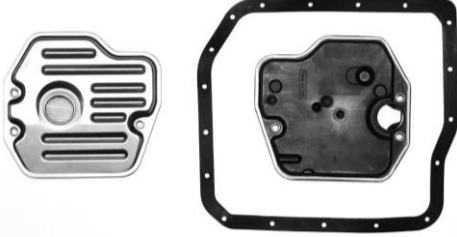

MODELO

AÑOS

Camry, Celica, Matrix, RAV-4, Highlander

00-10

MOTOR

L4, V6

TC 18 TRACC D, T OEM 35330-0W010 4 VEL

FC-U151E

U150E
U151E
U250E

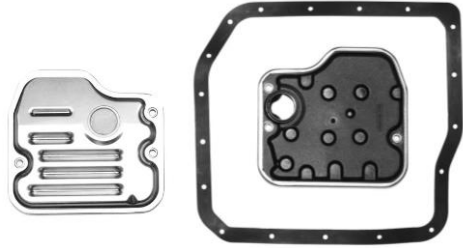

MODELO

AÑOS

Avalon, Corolla, Matrix, RAV-4, Sienna, Highlander, Camry

04-13

MOTOR

V6

TC 18 TRACC D OEM 35330-08010 5 VEL

FC-U341E

U341E

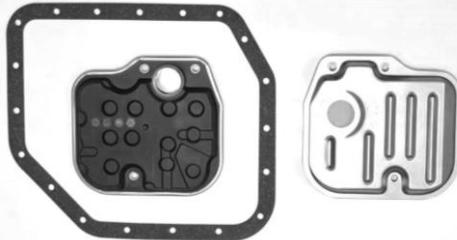

MODELO

AÑOS

Corolla, Matrix, Yaris

03-12

MOTOR

L4

TC 19 TRACC AWD OEM 35330-20020 4 VEL

FC-U540E

U540E



MODELO

AÑOS

Toyota Yaris sedan (USA)

07-13

MOTOR

L4

TC N / R TRACC D OEM 35303-67206 4 VEL

1.4 Filtro y empaque de transmisión automática

Automatic transmission filter kits



Toyota

FC-U660E

U660E

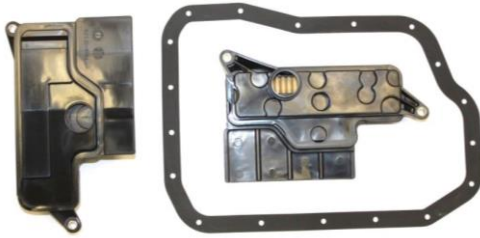

MODELO					AÑOS		
Toyota Camry,RAV4, Sienna, Matrix, Highlander,Corolla					03-13		
					MOTOR		
					V6		
TC	18	TRACC	D	OEM	35330-33050	6	VEL

Transmisión Allison

FC-AT540

AT540-543-545



MODELO					AÑOS		
Series AT540, AT543, AT545					72-00		
					MOTOR		
					--		
TC	21	TRACC	T	OEM	6837428	4	VEL

FC-HT700

SERIE HT700



MODELO					AÑOS		
Uso universal, serie HT-700 (tubo de 5" de alto)					72-00		
					MOTOR		
					--		
TC	21	TRACC	T	OEM	29538491	4	VEL

FC-HT740

SERIE HT740



MODELO					AÑOS		
Uso universal, serie HT740 (tubo de 6" de alto)					72-00		
					MOTOR		
					--		
TC	21	TRACC	T	OEM	6839945	4	VEL

FC-HT750

SERIE HT750

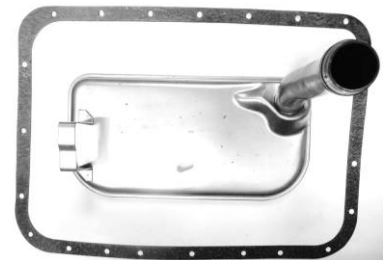

MODELO					AÑOS		
Uso Universal, serie HT750 (tubo de 7" de alto)					72-00		
					MOTOR		
					--		
TC	21	TRACC	T	OEM	23013625	4	VEL

1.4 Filtro y empaque de transmisión automática

Automatic transmission filter kits



Transmisión Allison

FC-L1000

1000/2000/2400

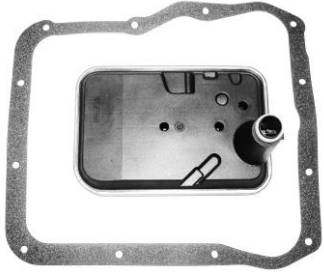

MODELO						AÑOS	
GM Silverado C2500, C3500, GMC Sierra 2500, 3500 (carter bajo)						01-12	
						MOTOR	
TC	12	TRACC	T	OEM	29537965	5	VEL

FC-L1000A

1000/2000/2400



MODELO						AÑOS	
GM Silverado C2500, C3500, GMC Sierra 2500, 3500 (carter profundo)						01-12	
						MOTOR	
TC	12	TRACC	T	OEM	29537966	5	VEL

FC-L1000CA

1000/2000/2400



MODELO						AÑOS	
GM Silverado C2500, C3500, GMC Sierra 2500, 3500 (filtro secundario)						01-12	
						MOTOR	
TC	NR	TRACC	T	OEM	29539579	5	VEL

FC-MT640

MT640-650



MODELO						AÑOS	
Series MT640, MT650						72-00	
						MOTOR	
TC	21	TRACC	T	OEM	6834831	4	VEL

Universales

FC-F38CA

(entrada de 3/8")



MODELO						AÑOS	
Filtro magnetico para enfriador de aceite						Todos	
						MOTOR	
TC	N/R	TRACC	D/T	OEM	N / D	todas	VEL

FC-F516CA

(entrada de 5/16")



MODELO						AÑOS	
Filtro magnético para enfriador de aceite						Todos	
						MOTOR	
TC	N/R	TRACC	D/T	OEM	N / D	Todas	VEL

1.4 Filtro y empaque de transmisión automática

Automatic transmission filter kits



Volkswagen

FC-329
JF506E

NUEVO PRODUCTO



MODELO					AÑOS	
Audi A3, Golf, Jetta, Bora 1.8L, 1.9L (02-07) (filtro con cuello de 16mm de alto)					02-07	
					MOTOR	
					L4	
TC	20	TRACC	D	OEM	5	VEL

FC-330
TF60SN

NUEVO PRODUCTO



MODELO					AÑOS	
Beetle 1.8L, 1.9L, 2.0L, Golf 2.0L, Jetta, Passat 1.8L, 2.0L, 2.5L, filtro sin cuello					03-14	
					MOTOR	
					L4,L5	
TC	8	TRACC	D	OEM	6	VEL

FC-331
DL501

NUEVO PRODUCTO



MODELO					AÑOS	
Audi A4, A5 2.0L,V6 3.2L, A6 V6 3.0L Q5 2.0L					07-12	
					MOTOR	
					L4,V6	
TC	15	TRACC	AWD	OEM	7	VEL

FC-332
TR80SD

NUEVO PRODUCTO



MODELO					AÑOS	
VW Touareg V6 3.0L, 3.6L, V8 4.2L, Audi Q7 V6 3.6L, V8 4.2L, Porsche Cayenne V6 3.0L, 3.6L, V8 4.2L, 4.8L					09-16	
					MOTOR	
					V6,V8	
TC	11	TRACC	AWD	OEM	8	VEL

FC-333
DQ500

NUEVO PRODUCTO



MODELO					AÑOS	
VW Tiguan 1.4L, 2.0L, Transporter 2.0L diesel, Audi Q3 2.0L (13-16) (filtro secundario)					09-15	
					MOTOR	
					L4,L5	
TC	N/R	TRACC	AWD	OEM	7	VEL

FC-334
VW09G

NUEVO PRODUCTO



MODELO					AÑOS	
VW Beetle, Jetta, Passat 1.8L, 2.5L					08-13	
					MOTOR	
					L4,L5	
TC	8	TRACC	D	OEM	6	VEL

1.4 Filtro y empaque de transmisión automática

Automatic transmission filter kits



Volkswagen

FC-335

01J



MODELO

AÑOS

Audi A4 1.8L, 2.0L, V6 2.8L, A6
V6 2.8L, 3.0L, 3.2L, A8 V8 4.2L

08-11

MOTOR

L4, V6, V8

TC	N/R	TRACC	AWD	OEM		CVT	VEL
----	-----	-------	-----	-----	--	-----	-----

FC-336

DQ380



MODELO

AÑOS

Audi A3 1.8L, VW Golf GTI,
Tiguan 2.0L

14-19

MOTOR

L4

TC	N/R	TRACC	D	OEM		7	VEL
----	-----	-------	---	-----	--	---	-----

FC-337

DQ500



MODELO

AÑOS

VW Tiguan 1.4L, 2.0L, Transporter 2.0L
diesel, Audi Q3 2.0L

09-16

MOTOR

L4

TC	N/R	TRACC	AWD	OEM		7	VEL
----	-----	-------	-----	-----	--	---	-----

FC-338

TF60SN



MODELO

AÑOS

Golf 1.8L, 2.0L,
Passat 2.0L

10-18

MOTOR

L4

TC	8	TRACC	D	OEM		6	VEL
----	---	-------	---	-----	--	---	-----

FC-339

0BT



MODELO

AÑOS

Tiguan 2.0L
Transporter 2.0L

09-14

MOTOR

L4

TC	N/R	TRACC	AWD	OEM		7	VEL
----	-----	-------	-----	-----	--	---	-----

FC-362

VW09P



MODELO

AÑOS

Tiguan 2.0L
Passat 2.0L

18-20

MOTOR

L4

TC	N/R	TRACC	D/AWD	OEM		7	VEL
----	-----	-------	-------	-----	--	---	-----

1.4 Filtro y empaque de transmisión automática

Automatic transmission filter kits



Volkswagen

FC-4HP18FLA
ZF4HP18FLA



MODELO						AÑOS	
Audi 100 Quattro, A6 Quattro, A8 Quattro, Porsche 911						92-97	
						MOTOR	
TC	N/R	TRACC	AWD	OEM	01F-325-433	4	VEL

FC-5HP19
ZF5HP19/FLA



MODELO						AÑOS	
Passat, Audi A4, A6						96-04	
						MOTOR	
TC	27	TRACC	D	OEM	01V-325-429	5	VEL

FC-AL450
AL450



MODELO						AÑOS	
Volkswagen Amarok 2.0L, V6 3.0L (11-16)						11-16	
						MOTOR	
TC	13	TRACC	T	OEM	0CM-301-519	8	VEL

FC-VW003
VW003



MODELO						AÑOS	
Dasher, Karmann Ghia, Thing, Transporter, Audi 100 Series, Audi Fox						69-76	
						MOTOR	
TC	13	TRACC	T	OEM	003 325 421	3	VEL

FC-VW010
VW 010



MODELO						AÑOS	
Caribe, Atlantic, Golf A2, Jetta A2						77-92	
						MOTOR	
TC	NR	TRACC	D	OEM	010-325-421A	3	VEL

FC-VW010A
VW 010



MODELO						AÑOS	
Caribe, Rabbit (USA)						75-76	
						MOTOR	
TC	NR	TRACC	D	OEM	010-325-421	3	VEL

1.4 Filtro y empaque de transmisión automática

Automatic transmission filter kits



Volkswagen

FC-VW010E

VW 097



MODELO		AÑOS	
Eurovan		91-95	
		MOTOR	
		L4	

TC	5	TRACC	D	OEM	095 325 429C/D	4	VEL
----	---	-------	---	-----	----------------	---	-----

FC-VW01J

01J MULTITRONIC



MODELO		AÑOS	
A4 , Cabriolet, A6		02-09	
		MOTOR	
		L4, V6	

TC	N / R	TRACC	D	OEM	01J 301 519L	CVT	VEL
----	-------	-------	---	-----	--------------	-----	-----

FC-VW02E

VW02E

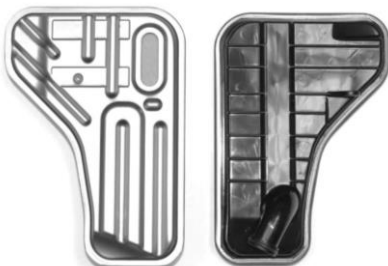

MODELO		AÑOS	
Audi TT, VW Rabbit		02-04	
		MOTOR	
		L5, V6	

TC	N / R	TRACC	D	OEM	02E-325-429	6	VEL
----	-------	-------	---	-----	-------------	---	-----

FC-VW02EN

VW02EN



MODELO		AÑOS	
VW Rabbit , Golf R32 , Golf GTI,Eos,Audi A3, Audi TT		05-08	
		MOTOR	
		L5, V6	

TC	N / R	TRACC	D	OEM	02E-325-429D	6	VEL
----	-------	-------	---	-----	--------------	---	-----

FC-VW095

VW 095 / 096



MODELO		AÑOS	
Golf A3 ,Jetta A3, Passat		90-96	
		MOTOR	
		L4	

TC	4	TRACC	D	OEM	095-325-429C	4	VEL
----	---	-------	---	-----	--------------	---	-----

FC-VW098

VW 098



MODELO		AÑOS	
Eurovan		96-03	
		MOTOR	
		Todos	

TC	5	TRACC	D	OEM	01P-325-429	4	VEL
----	---	-------	---	-----	-------------	---	-----

1.4 Filtro y empaque de transmisión automática

Automatic transmission filter kits



Volkswagen

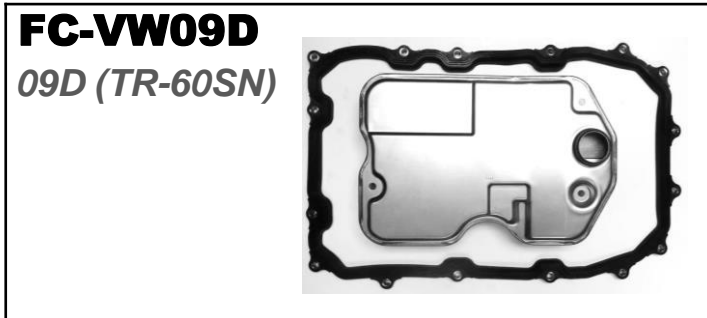

MODELO						AÑOS	
VW Touareg, Audi Q7						04-09	
						MOTOR	
						V6, V8, V10	
TC	16	TRACC	T/AWD	OEM	09D-325-429	6	VEL



MODELO						AÑOS	
Audi A8, Audi S6, Audi S8						04-08	
						MOTOR	
						V6, V8	
TC	13	TRACC	AWD	OEM	09E-325-429	6	VEL

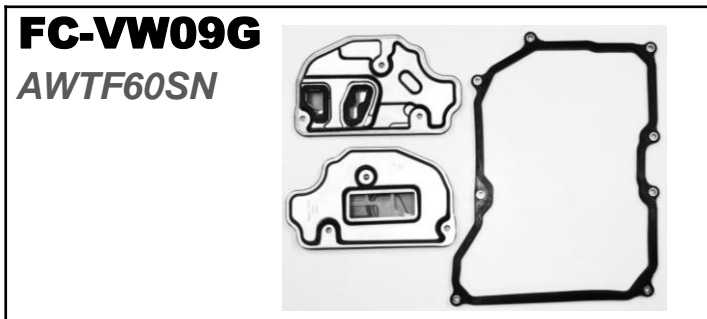

MODELO						AÑOS	
Beetle, Eos, Golf, Jetta, Passat, Rabbit, Bora						04-07	
						MOTOR	
						L4, L5, V6	
TC	8	TRACC	D	OEM	09G 325 429	6	VEL

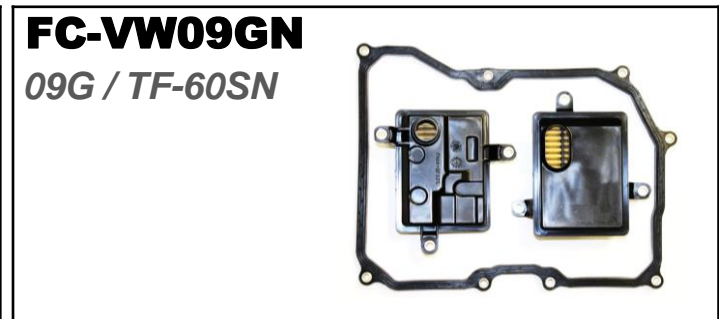

MODELO						AÑOS	
Volkswagen Beetle 1.8L, Jetta 1.8L, Passat 1.8L						14-17	
						MOTOR	
						L4	
TC	8	TRACC	D	OEM	09G-325-429D	6	VEL

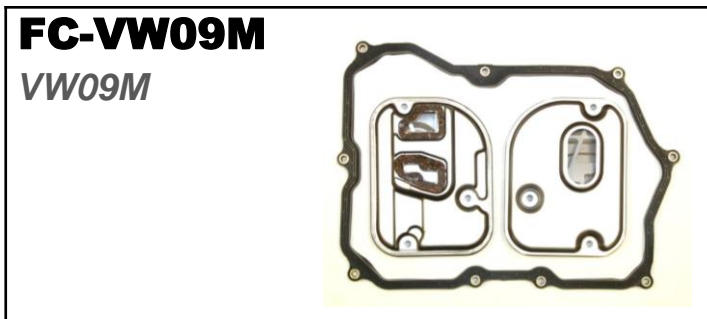

MODELO						AÑOS	
VW Passat 3.6L, VW Passat Wagon 3.6L						06-08	
						MOTOR	
						V6	
TC	9	TRACC	D	OEM	09M-325-429	6	VEL



MODELO						AÑOS	
Beetle, Golf, Jetta						96-05	
						MOTOR	
						L4	
TC	4	TRACC	D	OEM	01M-325-429	4	VEL

1.4 Filtro y empaque de transmisión automática

Automatic transmission filter kits



Volkswagen

FC-ZF6HP19A

ZF6HP19A

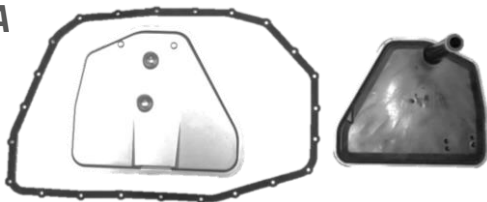

MODELO					AÑOS		
Audi A4 (05-08), A6 Audi S4 / RS4, VW Phaeton					04-08		
					MOTOR		
					V6, V8		
TC	23	TRACC	AWD	OEM	09L-325-429	6	VEL

FC-ZF8HP45

ZF8HP45



MODELO					AÑOS		
Audi Q7 3.6L					07-10		
					MOTOR		
					V6		
TC	13	TRACC	AWD	OEM	0AT-325-429	6	VEL

Volvo

FC-AW50

AW50-42LE







MODELO					AÑOS		
C70, S40, S70, S80, V70					98-04		
					MOTOR		
					L4, L5		
TC	N/R	TRACC	D/AWD	OEM	30681088	4	VEL

1.5 Moduladores Modulators



Ford

<p>MO-A4LD</p> 	<p>MO-C3</p> 	<p>MO-C4 A AMARILLO</p> 
<p>Camionetas 4 y V6, 4 vel, desde 89</p>	<p>Fairmont, Cougar, V6, V8 3 vel, desde 81</p>	<p>Autos y Camionetas V6, V8 3 vel, 69-81</p>
<p>MO-C4 R BLANCO CON ROSA</p> 	<p>MO-C4/C5 VERDE</p> 	<p>MO-C6 PÚRPURA</p> 
<p>Autos y Camionetas V6, V8 3 vel. 69-81</p>	<p>Autos y Camionetas V6, V8 3 vel. 69-81</p>	<p>Autos y Camionetas V8, 3 vel.</p>
<p>MO-C6 V VERDE</p> 	<p>MO-FMX VERDE CON ROSCA</p> 	<p>MO-FMX A AZUL CON ROSCA</p> 
<p>Autos y Camionetas V8, 3 vel.</p>	<p>Autos y Camionetas V8, 3 vel. 68-77</p>	<p>Autos y Camionetas V8, 3 vel. 68-77</p>

General Motors

<p>MO-TH350/400 CAFÉ</p> 	<p>MO-TH440</p> 	<p>MO-TH180</p> 
<p>TH250 y TH350 V6 y V8 3 vel. TH400 67-89</p>	<p>TH440T4/AT60 V6 y V8 4 vel. desde 89</p>	<p>TH180 GM Autos L4, 3 vel., 69-97</p>

1.5 Moduladores Modulators



Nissan

MO-JATCO

CON ROSCA



Nissan-Datsun, 4 cil.
3 vel. 71-87

Transmisión Allison

MO-AT540



Transmisiones Allison AT540, AT543,
AT545, 4 vel, 70 en adelante



LAS MÁS AMPLIA GAMA DE PRODUCTOS

- Filtro y empaque de transmisión automática
- Aros dentados
- Juegos de sellos para monoblock
- Guías de válvula
- Soportes de barra cardán
- Poleas de cigüeñal
- Tapas de distribución
- Horquillas de Clutch
- Partes para sistema de freno
- Partes para dirección
- Miscelánea

¿ALGUNA DUDA?
Comunicate con los expertos
01 800 227 5634

***Se un lider,
Se parte del mejor equipo***

1.6 Volantes estándar Flywheels



Ford

WOH-7001

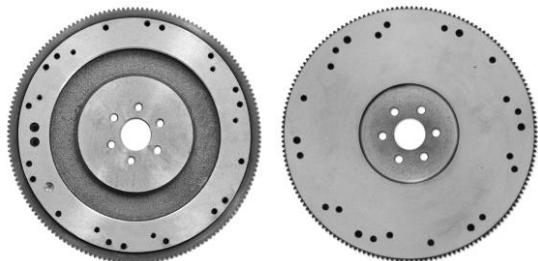

OEM	EOTZ-6375-A	No. Dientes	164	Diám. Ext.	14.25"
-----	-------------	-------------	-----	------------	--------

Pick ups F-100, F-150
L6 300 (4.9L) (80-96)

WOH-7002

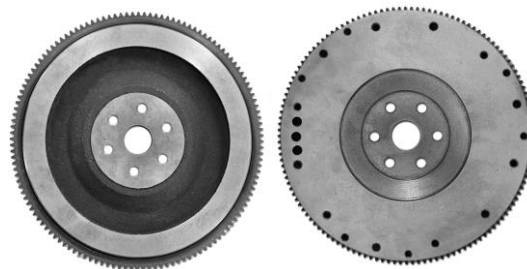

OEM	F0ZZ-6375-A	No. Dientes	132	Diám. Ext.	11.25"
-----	-------------	-------------	-----	------------	--------

Ford Ranger, Mazda B2300
L4 140 (2.3L) (83-96)

WOH-7003

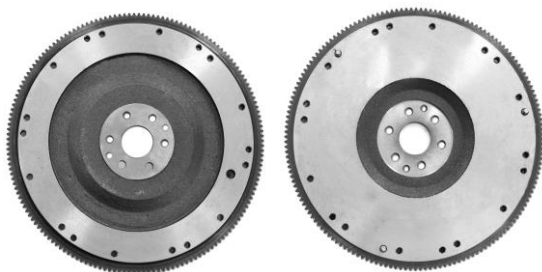

OEM	F6TZ-6375-AA	No. Dientes	164	Diám. Ext.	14.25"
-----	--------------	-------------	-----	------------	--------

Pick ups F-150
V6 4.2L (97-08)

WOH-7004

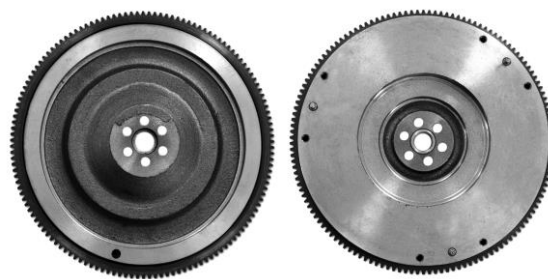

OEM	E5TZ-6375-E	No. Dientes	138	Diám. Ext.	11.46"
-----	-------------	-------------	-----	------------	--------

Ford Ranger V6 171 (2.8L) (1985),
177 (2.9L) (86-92)

WOH-7005

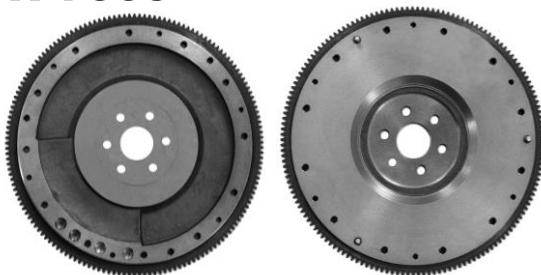

OEM	E6ZZ-6375-A	No. Dientes	157	Diám. Ext.	13.25"
-----	-------------	-------------	-----	------------	--------

Mustang V8 302 (5.0L) (86-95)

WOH-7007

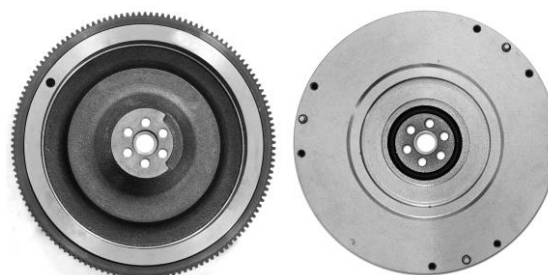

OEM	F0TZ-6375-A	No. Dientes	138	Diám. Ext.	11.46"
-----	-------------	-------------	-----	------------	--------

Ford Ranger, Mazda B4000
V6 4.0L (244) (90-97)

1.6 Volantes estándar Flywheels



Ford

WOH-7008

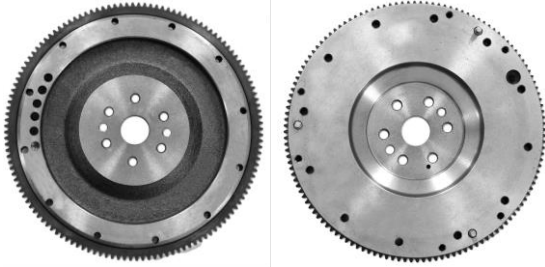

OEM	E69Z-6375-B	No. Dientes	132	Diám. Ext.	11.25"
-----	-------------	-------------	-----	------------	--------

Ford Ranger, Mazda B3000
V6 183 (3.0L) (86-94)

WOH-7009

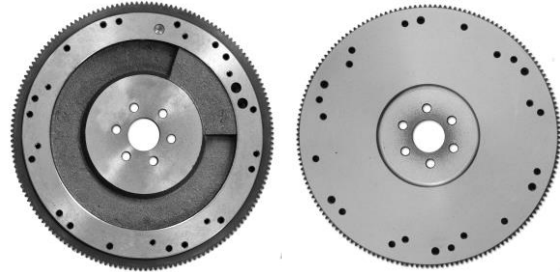

OEM	E8TZ-6375-D	No. Dientes	164	Diám. Ext.	14.25"
-----	-------------	-------------	-----	------------	--------

Pick ups F-100, F-150 V6 232 (3.8L),
V8 302 (5.0L), 351 (5.8L) (81-96)

WOH-7010

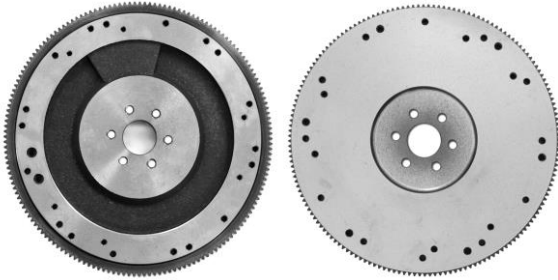

OEM	E8TZ-6375-C	No. Dientes	164	Diám. Ext.	14.25"
-----	-------------	-------------	-----	------------	--------

Pick ups F-100, F-150
V6 232, V8 302, 351 (67-87)

WOH-7011

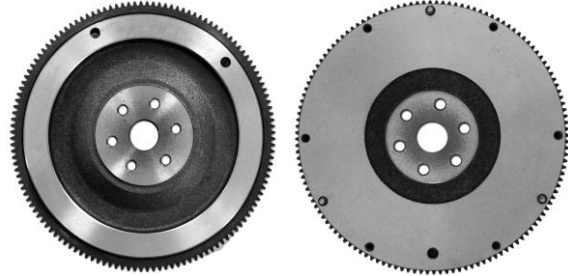

OEM	F57Z-6375-A	No. Dientes	132	Diám. Ext.	11.25"
-----	-------------	-------------	-----	------------	--------

Ford Ranger, Mazda B2300, B2500
2.3L, 2.5L (95-01)

WOH-7012

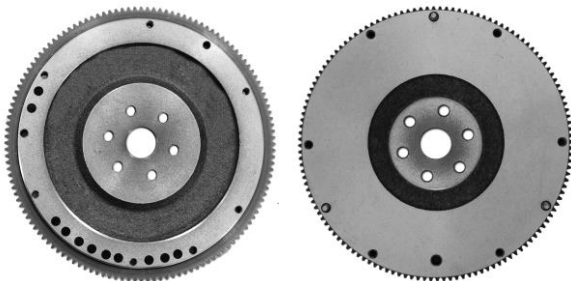

OEM	F0CZ-6375-A	No. Dientes	132	Diám. Ext.	11.25"
-----	-------------	-------------	-----	------------	--------

Ford Escort, Mercury Tracer
1.9L (91-96)

WOH-7013

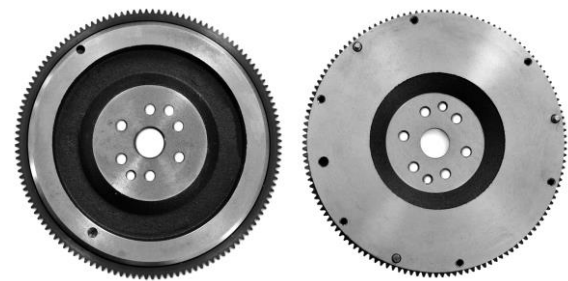

OEM	F57Z-6375-B	No. Dientes	132	Diám. Ext.	11.25"
-----	-------------	-------------	-----	------------	--------

Ford Ranger, Mazda B3000
V6 3.0L (95-05)

1.6 Volantes estándar Flywheels



General Motors

WOH-1000

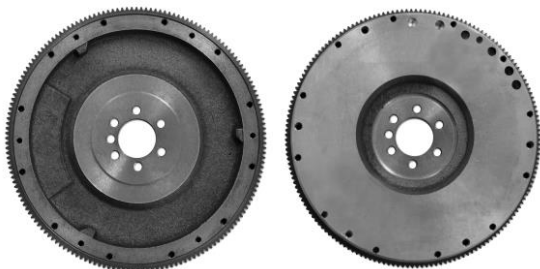

OEM	10105832	No. Dientes	168	Diám. Ext.	14.25"
-----	----------	-------------	-----	------------	--------

Chevrolet, GMC Pick ups V6 262 (4.3L),
V8 305 (5.0L), 350 (5.7L) (86-96)

WOH-1002

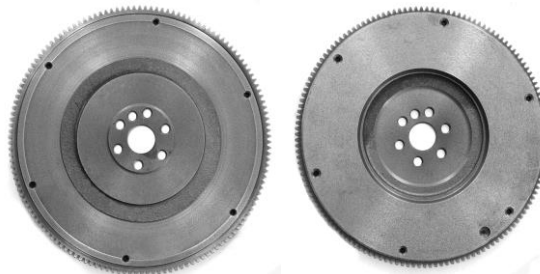

OEM	10118669	No. Dientes	142	Diám. Ext.	11.87"
-----	----------	-------------	-----	------------	--------

Chevrolet, GMC, Isuzu (autos y pick ups) L4 121 (2.0L),
134 (2.2L), V6 173 (2.8L), 189 (3.1L) (82-96)

WOH-1003

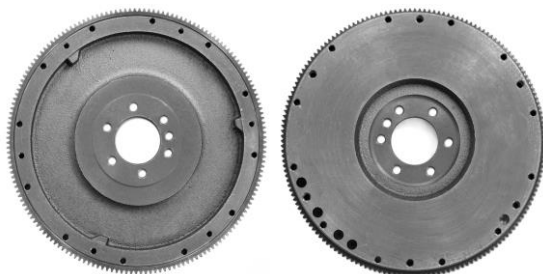

OEM	3991469	No. Dientes	168	Diám. Ext.	14.12"
-----	---------	-------------	-----	------------	--------

Chevrolet, GMC, Pontiac (autos y pick ups)
L6 250, V8 283, 307, 327, 350, 400, 402, 427 (67-85)

WOH-1004

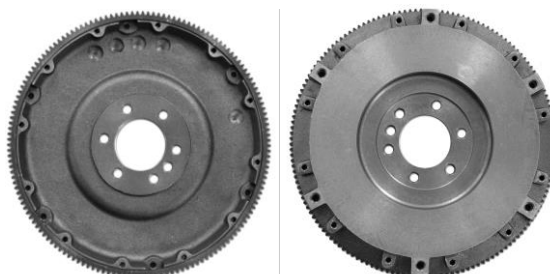

OEM	14085720	No. Dientes	153	Diám. Ext.	12.75"
-----	----------	-------------	-----	------------	--------

Chevrolet Camaro, Corvette, Pontiac Firebird
V8 305, 350, 427 (66-85)

WOH-1005

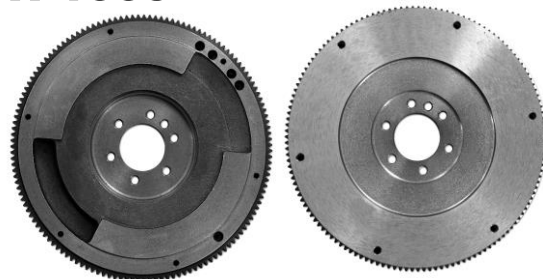

OEM	LFW126, 12556799	No. Dientes	139	Diám. Ext.	14"
-----	------------------	-------------	-----	------------	-----

Chevrolet, GMC Pick ups
V8 6.5L (diesel) (92-00)

WOH-1006

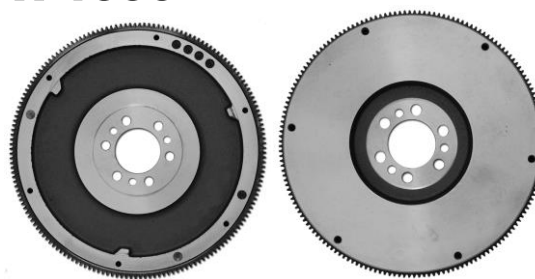

OEM	93414855	No. Dientes	168	Diám. Ext.	14.12"
-----	----------	-------------	-----	------------	--------

Chevrolet, GMC Pick ups
L6 292 (67-89)

1.6 Volantes estándar Flywheels



General Motors

WOH-1008

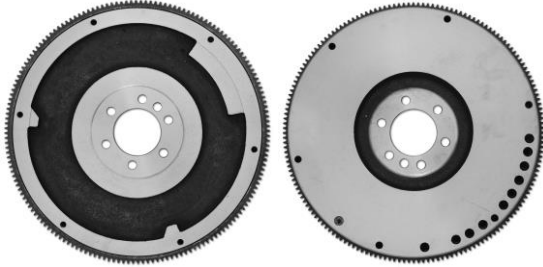

OEM	3993827	No. Dientes	168	Diám. Ext.	14.12"
-----	---------	-------------	-----	------------	--------

Chevrolet, GMC Pick ups
V8 454 (7.4L) (73-90)

WOH-1027

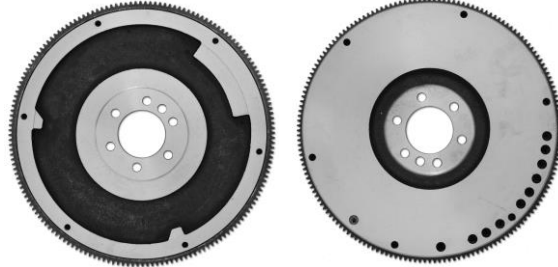

OEM	10101169	No. Dientes	168	Diám. Ext.	14"
-----	----------	-------------	-----	------------	-----

Chevrolet, GMC Pick ups
V8 7.4L (91-95)

WOH-1500

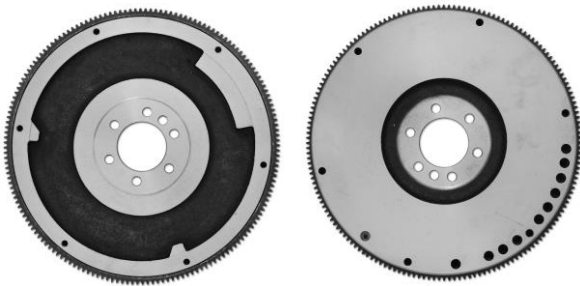

OEM	3986394	No. Dientes	168	Diám. Ext.	14"
-----	---------	-------------	-----	------------	-----

Chevrolet, GMC Pick ups
V8 454 (70-80)

Jeep

WOH-2000

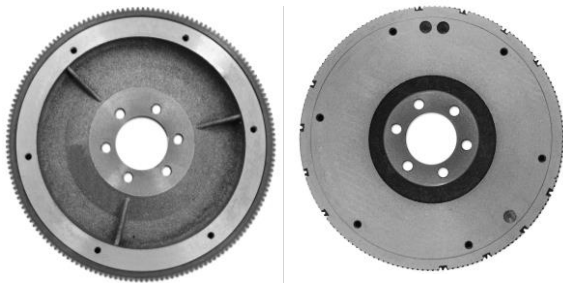

OEM	53005524	No. Dientes	164	Diám. Ext.	13.83"
-----	----------	-------------	-----	------------	--------

Jeep Cherokee, Grand Cherokee, Comanche,
Wrangler L6 4.0L (91-05)

1.6 Volantes estándar Flywheels



Nissan

WOH-3000

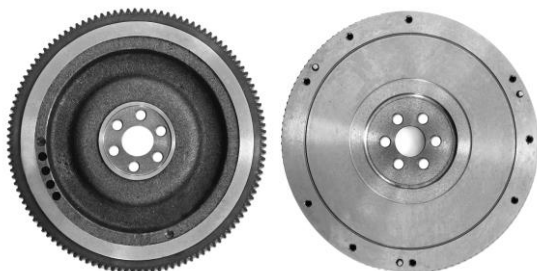

OEM	1231085G06	No. Dientes	120	Diám. Ext.	12.50"
-----	------------	-------------	-----	------------	--------

Nissan Pick ups L4 1952cc, 2187cc, 2389cc
(motores Z20, Z22, Z24), 2.4L (KA24E) (83-97)

Subaru

WOH-4000

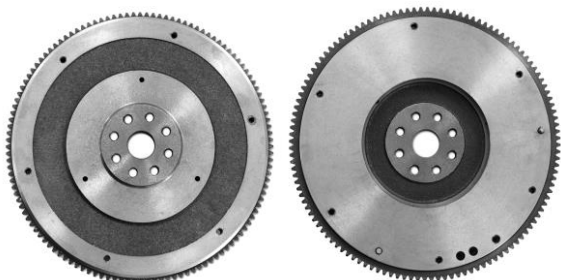





OEM	12310AA090	No. Dientes	124	Diám. Ext.	12.42"
-----	------------	-------------	-----	------------	--------

Impreza, Legacy
H4 1.8L, 2.2L (90-01)







2.1 Horquilla de clutch Clutch fork



American motors

<p>HC-AMC</p>  <p>5361620</p> <p>Cherokee, Jeep CJ5 y CJ7 Wagoneer, J10/20 (80-87)</p>	<p>HC-AMC C/P</p>  <p>3224192</p> <p>Rambler, Gremlin, Pacer (64-87) Jeep Wagoneer, Cherokee (76-80) (con pernos para portacollarin)</p>	<p>HC-AMC 13</p>  <p>1378486</p> <p>Jeep CJ5 (1965-1973)</p>
<p>HC-AMC 11</p>  <p>3217480</p> <p>Jeep Wagoneer, J10, J20 (74-79)</p>		

Chrysler / Dodge

<p>HC-D ATOS</p>  <p>41430-02010</p> <p>Dodge Atos L4 1.0L (01-adelante)</p>	<p>HC-D 100</p>  <p>3643998</p> <p>Camionetas Dodge serie D 100 y D 300, hasta modelo 1979</p>	<p>HC-D 150</p>  <p>4210697</p> <p>Camionetas Dodge serie D 150 y D 350 modelos 1980 en adelante</p>
<p>HC-D 150 H6</p>  <p>04340215</p> <p>Camioneta Dodge 6 cil. Modelos 1988 en adelante clutch hidraulico</p>	<p>HC-D 150 HV6</p>  <p>52107555</p> <p>Camioneta Dodge serie D150 motor V6 modelos 1992 en adelante (clutch hidraulico)</p>	<p>HC-D 150 H8</p>  <p>04446231</p> <p>Camioneta Dodge 8 cil. Modelos 1988 en adelante (clutch hidráulico)</p>

2.1 Horquilla de clutch Clutch fork



Chrysler / Dodge

<p>SHC-D 150 H8</p>  <p>04338855</p> <p>Seguro para HC-D 150 H8</p>	<p>HC-D 600</p>  <p>3640749</p> <p>Camión Dodge serie D 600 Modelos 1974 en adelante</p>	<p>HC-D 600 H</p>  <p>4559956</p> <p>Camión Dodge serie D 600 Modelos 1992 en adelante (clutch hidraulico)</p>
---	---	--

Dina

<p>HC-DINA</p>  <p>A-160592-27</p> <p>Camioneta Dina 3200 con motor Perkins de 4 cil. y Dina 5121, con motor Perkins de 6 cil.</p>
--

Ford

<p>HC-E7TZ</p>  <p>E7TZ-7515-A / Z7TA-7515-A</p> <p>Camioneta Ford F 450 Super Duty, Volante Plano (94 en adelante)</p>	<p>HC-72TY</p>  <p>B8C-7515A / 72TY-7515AA</p> <p>Camión Ford Serie 600 F, LN, C (1958-79)</p>	<p>HC-D8TZ</p>  <p>D8TZ-7515-A</p> <p>Camioneta Van (75-79)</p>
<p>HC-D0TZ</p>  <p>D0TZ-7515A</p> <p>Camioneta Ford series F-100 a F-350 americana con motor 300, 302, 351, 360, 390 y 400</p>	<p>HC-E4TZ</p>  <p>E4TZ-7515 C</p> <p>Camionetas Ford, Van y Bronco (americanas) series F-100 a F-350 6 cil. en linea modelos 84 en adelante y (nacionales) V-6 modelos 85 en adelante</p>	<p>HC-E0TZA</p>  <p>E0TZ-7515-A</p> <p>Camioneta Ford y Van, series F-100 a F-350 con motor 255, 300, 302, 351W (80-81), Van (80-82)</p>



2.1 Horquilla de clutch Clutch fork



Ford

HC-E0TZB

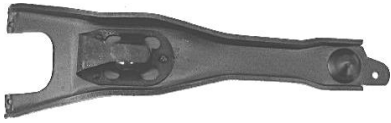

E0TZ 7515 B

Camioneta Ford series F-100 a F-350 con motor 400 (79-81) 351M (80-81)

HC-F81Z



F81Z-7515-AC

Camioneta Ford F350 Super Duty y Tritón volante de caja (99 en adelante)

HC-XR3Z



XR3Z-7515-AA

Ford Mustang V6 3.8L (94-03), V6 4.0L (2004), V8 4.6L (96-04), V8 5.0L (94-95)

HC-Z5TA

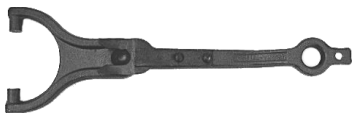

Z5TA-7515-A

Camioneta Ford F100, F150 y F350, modelos 1969 en adelante

General Motors

HC-GMCHEVY



90086134

Chevy 99-07

HC-GM

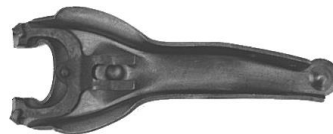

340278 / 14066235

Chevrolet con motor 292, 350, 231, 250, 262, 305 y 307

HC-GM2



15592270

Camioneta Chevrolet y GMC, serie C, K y V motor 6 cil. 292 y motor V8 305, 350, 454 y 6.2L Diesel, modelos 1985 en adelante

HC-GM2H



15588262

C, K, S10/S15 Transmisión Getrag (1988 – en adelante)

HC-GM3H



12385352

C, K, S10/S15 Camionetas (92 en adelante)

HC-GM5











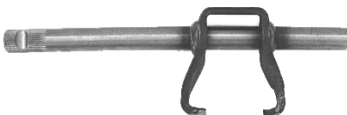

3765372 / 15687296

P10 / 50, C50 (70 en adelante)

2.1 Horquilla de clutch Clutch fork

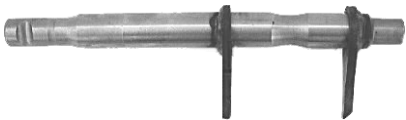

General Motors

<p>SHC-GM5</p>  <p>838987</p> <p>seguro</p>	<p>HC-GM6</p>  <p>93402800 / 14024930</p> <p>Cavalier, Celebrity, Citation V6 (1982-1986)</p>	<p>JBH-GM6</p>  <p>Jgo. De bujes Para HC-GM6</p>
<p>HC-GM 8</p>  <p>3765371 / 15687296</p> <p>Series 60 y 70 Motores 350,366 (73-91)</p>	<p>HC-GM27</p>  <p>15687298</p> <p>Series 60 & 70 motores 350,366 (91 en adelante)</p>	<p>HC-GM28</p>  <p>14070374</p> <p>S 10/15 transmisión Warner hidráulica 1984 en adelante</p>
<p>HC-GM29</p>  <p>15574633</p> <p>Chevrolet Kodiak, C6500,C7500 (90-02), 5 y 6 vel.</p>	<p>HC-GM61</p>  <p>8672090 / 8672942</p> <p>V6 Cavalier 5 vel (88-89) V6 II series (89 en adelante)</p>	<p>HC-GM62</p>  <p>8672937</p> <p>V6 Cavalier (87-88)</p>
<p>HC-GM63</p>  <p>8672510</p> <p>V6 Cavalier 5 vel (89 en adelante)</p>	<p>HC-GMATIZ</p>  <p>OEM# 96325013</p> <p>Pontiac Matiz L4 1.0L (04-07)</p>	

2.1 Horquilla de clutch Clutch fork



Nissan

HC-DATSUN



30531-B5050

Automóvil modelos 74-83 y camioneta todos los modelos D21 incluye seguro.
Nissan Urvan 2.4L (02-08),
Pick Up D22 (08-14)

SHC-DATSUN

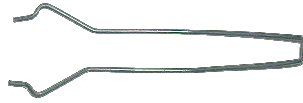

L 130534-E 9000

seguro

HC-NTSURU



30537-M8005

Tsuru III (84-07)

HC-N1.6



30531-00QAA

Nissan Platina , Renault Kangoo
Megane (02-adelante)

Toyota

HC-THILUX



31204-35031

Toyota Hilux (05-09)
Toyota Hiace (06-12)

2.1 Horquilla de clutch Clutch fork



Volkswagen

HC-VWPOINTER	HC-VWA3	HC-VWA4
		
013 141 701	02J 141 719C	016 141 719A
Pointer 97-07	Jetta A3, Seat Ibiza y Eurovan (93-99)	Jetta A4 y Eurovan (99-adelante)





MAX [®] By 
performance





BOMBAS DE GASOLINA PARA UN ENCENDIDO PERFECTO











2.2 Tornillo horquilla de clutch Clutch ball studs



<p>THC-0</p> 	<p>THC-1</p> 	<p>THC-2</p> 	<p>THC-3</p> 
<p>2054961 Chevrolet 6 cilindros</p>	<p>Chevrolet 6 cilindros Juego completo</p>	<p>Dodge (71-74)</p>	<p>633238 Camión Dodge Serie D 600 rosca hembra</p>

















<p>THC-3M</p> 	<p>THC-3J</p> 	<p>THC-4</p> 	<p>THC-5</p> 
<p>Tornillo macho para THC-3</p>	<p>Camión Dodge Serie D600 juego completo</p>	<p>A181 Willys Jepp</p>	<p>3898610 Chevrolet (62-72)</p>

<p>THC-6</p> 	<p>THC-6L</p> 	<p>THC-7</p> 	<p>THC-8</p> 
<p>3725240 Chevrolet 6 cilindros</p>	<p>Chevrolet Tornillo largo</p>	<p>3866568 Chevrolet (62-81)</p>	<p>C5ZZ-7A531-K Ford Falcon (63-65) Mustang (65-69)</p>

<p>THC-9</p> 	<p>THC-10</p> 	<p>THC-11</p> 	<p>THC-11L</p> 
<p>C8UZ-7A535-A Camioneta Ford Series F-150, F-250 y F-350 modelos (69-79)</p>	<p>4529447 Camioneta Dodge rodado sencillo y doble. Tornillo soporte de maroma o balancín</p>	<p>TAAA-7522-A Camión Ford F-600</p>	<p>Camión Ford F-600 Mod. 1981 en adelante</p>



2.2 Tornillo horquilla de clutch Clutch ball studs



<p>THC-12</p> 	<p>THC-12L</p> 	<p>THC-13</p> 	<p>THC-13 LC</p> 
<p>2461765 Camión Dodge Serie D 600. Tornillo soporte de maroma o balancín (65-84)</p>	<p>2461766 Camión Dodge Serie D 600 Tornillo soporte de maroma o balancín largo (65-84)</p>	<p>3729000 Automóvil Chevrolet</p>	<p>15592268 Camioneta Chevrolet C-15 y C-35 modelos 1987 en adelante (clutch hidráulico)</p>
<p>THC-14</p> 	<p>THC-15</p> 	<p>THC-16</p> 	<p>THC-17</p> 
<p>4210696 Automóvil Dodge y camioneta D150 6 cilindros, modelos 1982 en adelante. Tornillo para la campana de clutch</p>	<p>4210695 Automóvil Dodge y camioneta D150 8 cilindros, modelos 1982 en adelante, tornillo para la campana de clutch</p>	<p>326581 Camioneta Chevrolet modelos 1975-1987</p>	<p>30537K20G0 Automóvil Datsun modelos 1974 a 1983 y camionetas Datsun y Nissan todos los modelos /A-10)</p>
<p>THC-18</p> 	<p>THC-18 E</p> 	<p>THC-19</p> 	<p>THC-GM2 H</p> 
<p>E3TZ-7B602-D Camioneta Ford Clutch hidráulico (83-96)</p>	<p>Camioneta Ford (Clutch hidráulico) 90 en adelante con estriado (moletado)</p>	<p>E3TZ-TB60 2A Microbus Ford (Clutch hidráulico) 90 en adelante</p>	<p>15552866 Camioneta Chevrolet sencilla y doble rodado C-15, C-25 y C-35 modelos 1992 en adelante (clutch hidráulico)</p>
<p>THC-20</p> 	<p>THC-21</p> 	<p>THC-22</p> 	<p>THC-23</p> 
<p>General Motors GM S-10 12545771</p>	<p>General Motors GM S-10 Blazer 15679715</p>	<p>General Motors Kodiak (00-02), Topkick, C4500, C6500, C7500 (94-03)</p>	<p>14036058 General Motors Astro 85-89, Camaro 82-92, Pontiac Firebird 82-92</p>



2.2 Tornillo horquilla de clutch Clutch ball studs



THC-24	THC-25	THC-26
 <p>23049797 General Motors Chevrolet y GMC Pick ups Serie C/K 1500 y 2500 88-95</p>	 <p>31236-35030 Toyota Hilux (05-09)</p>	 <p>30537-0H601 Nissan Urvan (00-11)</p>

2.3 Maromas o balancines Bellcrank

Chrysler

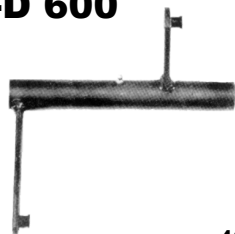
MOB-D 100	MOB-D 150	MOB-D 600
 <p>J036457</p> <p>Camioneta Dodge serie D 100 Modelos 1965-1980</p>	 <p>4210692</p> <p>Camioneta Dodge series D 150 y D 350 Modelos 1981-1989</p>	 <p>4036473</p> <p>Camión Dodge serie 600, modelos 1974 en adelante</p>



Ford

MOB-F 100	MOB-F 150	MOB-F 600
 <p>78TY7528AA</p> <p>Camioneta F 100 hasta modelo 1979</p>	 <p>83TM-7528B</p> <p>Camioneta Ford series F 150, F 200 y F 350 modelos 1980 en adelante</p>	 <p>C7TZ-7A572A</p> <p>Camión Ford serie F-600</p>









2.3 Maromas o balancines Bellcrank



General Motors





<p>MOB-GM</p>  <p>340607</p> <p>Camioneta rodado sencillo y doble modelos 1976-1987</p>	<p>MOB-GM2</p>  <p>14053618 / 330102</p> <p>Microbús C-30, P-30 modelos 1982 en adelante</p>
---	--

2.4 Tornillo o varilla de ajuste para horquilla de clutch Clutch Push Rod

<p>T-1</p>  <p>3820105</p>	<p>T-2</p>  <p>3820105</p>	<p>T-3</p>  <p>2830860</p>	<p>T-4</p>  <p>3748078</p>
<p>Camión Chevrolet Series 50,60 Diám. 9.4 mm (3/8") Longitud 370 mm (14 5/8")</p>	<p>Camión Dodge cil. secundario serie 500 y 600 con frenos hidráulicos. Diám. 9.4 mm (3/8") Longitud 125 mm (4 15/16")</p>	<p>Automóvil y Camioneta Dodge maquina 170 y 225 Diám. 9.4 mm (3/8") Longitud 141 mm (5 9/16")</p>	<p>Camión Dodge cil. Secundario Series 500 y 600 con frenos hidraulicos</p>
<p>T-5</p>  <p>DOTZ-7521-D</p>	<p>T-6</p>  <p>30614-38</p>	<p>T-6L</p> 	<p>T-7</p>  <p>43066-88</p>
<p>Camión Ford series F y B 600 modelos 1967 en adelante, longitud 315 mm (12 7/16") Diám. 9.4 mm (3/8")</p>	<p>Clutch Superior Longitud 197 mm (7 11/16")</p>	<p>Clutch Superior Longitud 181 mm (7 1/8")</p>	<p>Clutch inferior Longitud 181 mm (7 1/8")</p>





2.5 Templadores, ajustes, porta horquillas de clutch y seguros- Clutch linkage rod



CUADRO DE AJUSTE DE CLUTCH		PERNO DE HORQUILLA	MARIPOSA	HORQUILLA
CAC-1  3918467	CAC-1 C/R  3918467 C/R	PH-1 	M-1  3765322	H-1  6359-38
Cuadro de ajuste para varilla de clutch Camioneta Chevrolet Series 10,20,30 y Automóvil Rambler		Perno para Horquilla H-1 Diám. 9.4 mm (3/8")	Mariposa para varilla empuje Horquilla Clutch Chevrolet	Horquilla para perno de bomba de clutch superior. Camión Dina Series 3000, 3200, 531, 631 y 661 todos los modelos

PORTAHORQUILLA DE CLUTCH		SEGURO PORTACOLLARIN	SEGURO PARA MAROMA
CHP-1  2800848	CHP-2  2260719	SAP-D 531 	SAM-D150  2401910
Modelos 1973 en adelante	Modelos 1963 a 1972	Seguro de alambre para portacollarín Camión Dina 531	Seguro para Maroma Dodge D100, D150















TEMPLADOR DE CLUTCH

TC-1  3659187	TC-2  3676454
Automóvil y camión Chevrolet	Automóvil Chevrolet y camionetas Panel
TC-3  906146	TC-4  906158
Willys Jeep, todos los modelos	Ajuste de clutch Willys Jeep, todos los modelos

3.1 Tuercas para caja de velocidades Gearbox nuts



Tuercas para flecha de salida de la caja de velocidades con inserto de nylon

<p>TCV-18</p> 	<p>TCV-18F</p> 	<p>TCV-20</p> 	<p>TCV-20F</p> 
<p>Rosca: Standard Diámetro: 1 3/4" Caja Spicer fase I (7,10 y 14 vel.)</p>	<p>Rosca: Fina Diámetro: 1 3/4" Caja Spicer fasell (7,10 y 14 vel.)</p>	<p>Rosca: Standard Diámetro: 1 1/4" Flecha deslizante Dina 600</p>	<p>Rosca: Fina Diámetro: 1 1/4" Piñon Dina 531</p>
<p>TCV-21</p> 	<p>TCV-21F</p> 	<p>TCV-22F</p> 	<p>TCV-23F</p> 
<p>Rosca: Standard Diámetro: 1 1/2"</p>	<p>Rosca: Fina Diámetro: 1 1/2"</p>	<p>Rosca: Fina Diámetro: 1"</p>	<p>Rosca: Fina Diámetro: 2"</p>
<p>TCV-23FC</p> 	<p>TCV-24</p> 	<p>TCV-24F</p> 	<p>TCV-25F</p> 
<p>Rosca: Fina Diámetro: 2"</p>	<p>Rosca: Standard Diámetro: 1 1/8"</p>	<p>Rosca: Fina Diámetro: 1 1/8"</p>	<p>Rosca: Fina Diámetro: 1 5/8"</p>
<p>TCV-26</p> 	<p>TCV-27F</p> 	<p>TCV-33</p> 	
<p>Rosca: Standard Diámetro: 1 7/8"</p>	<p>Rosca: Fina Diámetro: 1 3/8"</p>	<p>Rosca: Izquierda</p>	

3.1 Tuercas para caja de velocidades Gearbox nuts



Tuercas de campana

TCM-28  Rosca: Standard Diámetro: 1 ¼"	TCM-28F  Rosca: Fina Diámetro: 1 ¼"	TCM-29  Rosca: Standard Diámetro: 1 ½"
TCM-29F  1227J946 Rosca: Fina Diámetro: 1 ½"	TCM-30  Rosca: Standard Diámetro: 1 ¾"	TCM-30F  Rosca: Fina Diámetro: 1 ¾"



Visita nuestra pagina
www.lodi.com.mx

Soporte Técnico
01 800 227 5634

 **LODI Industrias Automotrices**
 **@IALodi**

4.1 Arañas, guasas y tuercas de housing

Rear axle hardware

JTA-1



AH-1
3663659
Int. 51 mm (2")



GH-1
3663658
Int. 51 mm (2")
Ext. 66 mm (2 1/2")



TH-1
3663657

Camioneta Chevrolet rodado sencillo



AH-2
473692
Int. 55 mm (2 5/32")



GH-2
473628
Int. 54 mm (2 1/8")
Ext. 80 mm (3 5/32")



TH-2
473636

Camioneta Chevrolet doble rodado



AH-3
3703703
Int. 63.5 mm (2 1/2")



GH-3
3703704
Int. 64 mm (2 33/64")
Ext. 97 mm (3 53/64")



TH-3
3703711

Camión Chevrolet Series 500 y 600

JTA-4



AH-4
1925818
Int. 67 mm (2 21/32")



TH-4
4032402
Int. 2 5/8"

Camión Dodge Serie D 600 con frenos de aire 67678-R, modelos 1974 en adelante; Camión Dina 531 y 5121; International y para todo tipo de Camión con diferencial de 18,500 Lbs.



AH-5
2229883
Int. 64 mm (2 33/64")



TH-5
4032401

Camión Dodge Series D 500 y D 600 con frenos hidráulicos 36415-H hasta el modelo 1973, Camión International Series R y L y para todo tipo de camión con diferencial de 15,000 y 17,000 Lbs

JTA-6



AH-6
B6Y-1124-A
Int. 52 mm (2 1/64")



TH-6
B6Y-4252-A

JTA-6N



TH-6 N
D 5UZ-4255-A
(con candado de Nylon)
Modelos 1980 en adelante

Camioneta Ford F 350 doble rodado

JTA-7A



AH-7 A
B4T-1124
Int. 64.15 mm (2 17/32")



TH-7 C/P
B4T-4255
(con perno)
Int. 2 1/2"



TH-7
B4T-4258
Int. 2 1/2"

Camión Ford Series 500 y 600



AH-8
36416-H
Int. 63.5 mm (2 1/2")



TH-8
53395-H
Int. 2 1/2"



TH-8 C/R
53395-H
(con reten)
Int. 2 1/2"

Camión International Series R y L 160,170 y 180

JTA-9



AH-9
2909259
Int. 51 mm (2")



TH-9
2909258

Camioneta Dodge Series D300 doble rodado



AH-10
61-1124 A
Int. 46 mm (1 13/16")



TH-10
61-4252 A
Int. 1 13/16"

Camioneta Ford F 250 todos los modelos y Dodge Serie W-300

JTA-12



AH-11
90180
Int. 76 mm (3")



TH-11
31926
Int. 3"



TH-11 C/R
31926
(con reten
Int. 3")

Camiones Dina 631, Peña, Ramirez e International con diferencial Eaton 38 D y R 200



AH-12
90181
Int. 82.5 mm
(3 1/4")



TH-12
31927
Int. 3 1/4"



TH-12 C/R
31927
(con reten)
Int. 3 1/4"

Camiones Dina Serie 861, Kenworth, Autobus Masa Somex, White, Peña y Ramirez con diferencial Eaton 44 D y R 220

4.1 Arañas, guasas y tuercas de housing

Rear axle hardware



JUEGOS DE HOUSING

	PIEZA	CANT	PIEZA	CANT	PIEZA	CANT	PIEZA	CANT
JTA-1	TH-1	2	GH-1	1	AH-1	1	EMP-1	1
JTA-4	TH-4	2			AH-4	1	EMP-4	1
JTA-6	TH-6	2			AH-6	1	EMP-6	1
JTA-6N	TH-6N	1	JTA-6NS	1			EMP-6	1
JTA-7A	TH-7	1	TH-7C/P	1	AH-7	1	EMP-7	1
JTA-9	TH-9	2			AH-9	1	EMP-9	1
JTA-12	TH-12	2			AH-12	1	EMP-12/13	1
JTA-13A	TH-13	1	TH-13C/P	1	AH-13A	1	EMP-12/13	1
JTA-1415	TH-14	1	TH-15	1	AH-1415	1		
JTA-1415A	TH-14	1	TH-15C/P	1	AH-1415A	1		
JTA-1415AZ	TH-14	1	TH-15C/P	1	AH-1415A	1	AH-1415	1
JTA-21	TH-21	1	TH-22C/P	1	AH-22A	1		

JTA-13A



AH-13A
Int. 83.4 mm
(3 9/32")



TH-13 C/P
1227W517
(con perno)



TH-13
1227R330
Int. 3 1/4"

Camionetas Dina, Kenworth y Autocar con diferencial Rockwell SQDD, SQHD y SSHD

JTA-1415

Juego de tres piezas

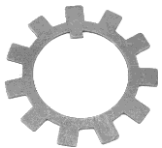

AH-1415
Int. 67.07 mm
(2 41/64")



TH-14
(tuerca octagonal)
Eje Sudisa



TH-15
(tuerca octagonal)
Int. 2 5/8"

JTA-1415 A

Juego de tres piezas



AH-1415A
Int. 67.07 mm
(2 41/64")



TH-14
(tuerca octagonal)
Int. 2 5/8"



TH-15 C/P
(tuerca octagonal)
Int. 2 5/8"

Eje Sudisa con Perno

JTA-1415AZ
AH-1415



TH-17
Eje delantero
Kenworth perno recto.
Int. 2 1/4"



TH-19
International
Int. 2 1/16"



AH-20



TH-20
Eje ligero Sudisa



AH-MB
470422C91
Camiones Mercedes Benz
Todos los modelos con
eje Eaton



TH-0
Willys



TH-16
Dodge 600
Int. 2 5/8"

JTA-21

Juego de tres piezas



AH-22A
Int. 3 1/2"



TH-21
Int. 3 1/2"



TH-22 C/P
Int. 3 1/2"







eje Fruehauf

4.1 Arañas, guasas y tuercas de housing

Rear axle hardware

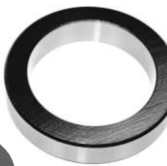

SEGUROS PARA BALERO DE RUEDA TRASERA

<p>SB-1</p> 	<p>SB-2</p> 	<p>SB-3</p> 	<p>SB-4</p> 
<p>Automoviles, Chevelle, Opel, Rambler, Datsun y Valiant con diferencial del país, para baleros SET 9 U298-261 y 48548-A y Tasa 48511 A. Int. 34.84 mm (1 23/64") Espesor 13 mm (1/2")</p>	<p>Camionetas Chevrolet y Dodge con diferencial del país, para baleros SET 10 U399-360 201047 y Tasa 201011. Int.39.62 mm (1 9/16")</p>	<p>Camioneta Ford Serie F 100 para Balero 88128. Int. 38.76 mm (1 17/32") Espesor 9.4 mm (3/8")</p>	<p>8A-1180 Automóvil Ford, para Baleros 88107, RW207CC, Rw307, Rw507 y Rw607. Int. 34.94 mm (1 3/8") Espesor 9.4 mm (3/4")</p>
<p>SB-5</p> 	<p>SB-6</p> 	<p>SB-7</p> 	
<p>Automóviles Ford y Dodge Para baleros RW-34R. Int. 33.94 mm (1 21/64") Espesor 7.9 mm (5/16")</p>	<p>Automóvil Ford para baleros RW-206 VR y RW 506 Int. 31.76 mm (1 1/4") Espesor 8.52 mm (21/64")</p>	<p>Pick ups Chevrolet (86-04), Pick ups Nissan (95->) Para balero SET80 U497 (9A4A3) / K444658</p>	



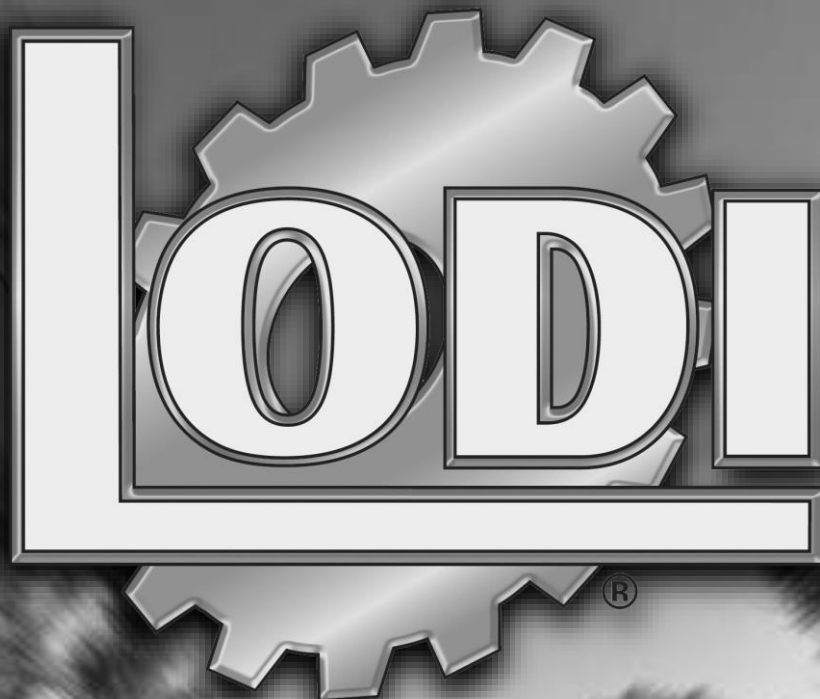

SINCE 1969

**SEGURIDAD TOTAL
EN EL CAMINO**



LODI Industrias Automotrices
Dale Like !

www.lodi.com.mx

5.1 Soportes para barra de cardán

Drive shaft support



GUARDA POLVOS GALVANIZADO CAL. 18



GP-107
Para baleros
88107



GP-508
Para baleros
88508



GP-509
Para baleros
88509



GP-510
Para baleros
88510



GP-512
Para baleros
88512

BALERO

BALERO CON GUARDAPOLVO



B-4



B-107



B-508



B-509



B-510



B-512

HULES



HS-4



HS-107



HS-N2.4



HS-508



HS-509



HS-510



HS-512

SOPORTES CON HULES



BC-4



BC-107



BC-508



BC-509



BC-510



BC-512



Soportes completos disponibles en caja, para pedirlos solo agregue una "C" al final del código

5.1 Soportes para barra de cardán Drive shaft support



Uso general

<p>BC-107 R</p>  <p>35mm</p> <p>Con balero 88107 Varios GM, Dodge, Ford Camionetas</p>	<p>BC-508 R</p>  <p>40mm</p> <p>Con balero 88508 Varios GM, Dodge, Ford 3 ½ Ton.</p>	<p>BC-509 R</p>  <p>45mm</p> <p>Con balero 88509 Dodge, Dina, Camiones</p>
---	---	---

<p>BC-510 R</p>  <p>50mm</p> <p>Con balero 88510 Varios GM, Dodge, Ford Camiones</p>	<p>BC-512 R</p>  <p>60mm</p> <p>Con balero 88512 Varios GM, Dodge, Ford camiones grandes</p>
---	---

Chrysler / Dodge

<p>BC-88536</p>  <p>40mm</p> <p>Dodge Ram 1500, 2500, 3500 (00-04), Dodge Dakota (00-02)</p>	<p>BC-438</p>  <p>40mm</p> <p>Pick up Ram 1500, 2500, 3500 (94-02), Ram Van 1500, 2500, 3500 (99-02)</p>	<p>BC-439</p>  <p>30mm</p> <p>Chrysler 300 (05-14), Dodge Charger (06-15), Dodge Challenger (09-14)</p>
---	---	--

Ford

<p>BC-201</p>  <p>40mm</p> <p>Ranger (01-11) (fabricada en Argentina)</p>	<p>BC-238</p>  <p>40mm</p> <p>Ford F-250, F-350, F-450 Super Duty (99-08)</p>	<p>BC-928</p>  <p>35mm</p> <p>Ford Ranger 2.2L (diesel), 2.5L (gasolina) (12-21)</p>
--	--	---

5.1 Soportes para barra de cardán

Drive shaft support



Ford

<p>BC-RAR</p>  <p>32mm</p> <p>Ford Ranger (83-89)</p>	<p>BC-RNR</p>  <p>30mm</p> <p>Ford Ranger (90-97)</p>
---	--

General Motors

<p>BC-126</p>  <p>30mm</p> <p>Chevrolet Equinox (05-07), Pontiac Torrent (05-07), Saturn VUE (02-07), Captiva Sport (2007)</p>	<p>BC-867</p>  <p>35mm</p> <p>Chevrolet S10 (85-93), C1500, C2500 (92-98), Silverado, GMC Sierra (99-07)</p>	<p>BC-88532</p>  <p>40mm</p> <p>Chevrolet S10 (85-93), C1500, C2500 (92-98), Silverado, GMC Sierra (99-07)</p>
<p>BC-4R</p>  <p>30mm</p> <p>Con balero 6206-ZZ GM Antiguos</p>	<p>BC-88505</p>  <p>40mm</p> <p>Chevrolet Van Express 2500, 3500 (00-02)</p>	<p>BC-88530</p>  <p>35mm</p> <p>Silverado 1500 2WD (00-04) Blazer S10 (94-00)</p>
<p>BC-88540</p>  <p>40mm</p> <p>Silverado 1500, 2500, 3500 (00-04) (con eje extendido)</p>	<p>BC-GS 10</p>  <p>40mm</p> <p>GM S10 (89-96)</p>	<p>BC-GMLUVR</p>  <p>25mm</p> <p>GM Chevy Luv (72-84)</p>

5.1 Soportes para barra de cardán Drive shaft support



General Motors

BC-IS2WDR



30mm

Isuzu Rodeo (91-97),
GM Colorado (05-10)

Honda

BC-10003



25mm

Honda CR-V (97-01)

BC-HB32



30mm

Honda Passport 4WD (94-98)

Isuzu

BC-1280-60



30mm

Isuzu Pick Ups (88-95) ,
Trooper (88-91)
Rodeo 2WD (89-adelante)

BC-2390-10



32mm

Isuzu Trucks ELF

BC-9720



25mm

Isuzu Luv 4WD (72-89)

BC-HB33



30mm

Isuzu Trooper (92-95)

5.1 Soportes para barra de cardán

Drive shaft support



Mazda

<p>BC-MAB2000R</p>  <p>25mm</p> <p>Mazda Pick Up (85-adelante)</p>	<p>BC-MAB1600R</p>  <p>25mm</p> <p>Mazda Pick Ups (77-84)</p>	<p>BC-MAB2600R</p>  <p>28mm</p> <p>Mazda B2600, B3000 (91-adelante)</p>
--	--	---

<p>BC-MABT50</p>  <p>28mm</p> <p>Mazda B2200 (90-adelante), B2500 (96-00), BT-50 (07-09)</p>	<p>BC-MAT3000</p>  <p>35mm</p> <p>Mazda B2200 2WD (82-87)</p>
--	---

Mercedes Benz

<p>BC-875</p>  <p>47mm</p> <p>Mercedes Benz Sprinter, Volkswagen Crafter (06-09) OEM # A9064100181</p>	<p>BC-HB4574</p>  <p>45mm</p> <p>Mercedes Benz Sprinter (00-06)</p>
--	--

5.1 Soportes para barra de cardán Drive shaft support



Mitsubishi

BC-HB14



30mm

Mighty Max (83-88),
Dodge Ram 50 (85-88)

BC-HB22



30mm

Mighty Max 2WD (90-92)
Pick Up L200 2WD (87-01)

BC-HB30



30mm

Montero Sport (97-04)
Dodge Ram 50 (87-91)

BC-MMAXR



30mm

Mitsubishi (83-88)

Nissan

BC-306R



30mm

Nissan Americana 2.4L

BC-33G25



30mm

Pathfinder 4WD (87-95)
Pick D21 4WD (86-95)

BC-36G25



30mm

Nissan Pick ups 4WD
(87-adelante)

BC-41L25



30mm

Nissan Pick ups (84-95)
Nissan Xterra, NP300 (14-19)

BC-J2100

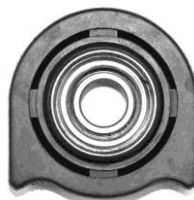

30mm

Nissan Pick ups 4WD
(89-adelante)

BC-N720R



30mm

Nissan Pick Up 720
(80-86) (BAJO)

5.1 Soportes para barra de cardán

Drive shaft support



Nissan

<p>BC-N2.4R</p>  <p>40mm</p> <p>Nissan Pick Up 2.4L (92-adelante)</p>	<p>BC-NDAR</p>  <p>30mm</p> <p>Nissan Pick Up (84-95) Maxima (82-84), Infiniti M30 (90-93) (Doble Anillo)</p>	<p>BC-NUSR</p>  <p>30mm</p> <p>Nissan Pick Up (USA) (73-90) (ALTO)</p>
--	--	--

<p>BC-NP4R</p>  <p>30mm</p> <p>Nissan Pick Ups, Pathfinder 4X4 (86-95)</p>
--

Toyota











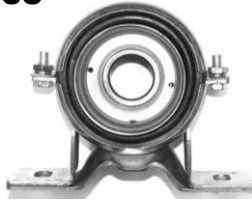

<p>BC-895</p>  <p>30mm</p> <p>Highlander (01-10) (delantero)</p>	<p>BC-896</p>  <p>30mm</p> <p>Highlander (01-10) (trasero), Sienna (04-10)</p>	<p>BC-899</p>  <p>30mm</p> <p>RAV4 (01-05)</p>
--	---	--

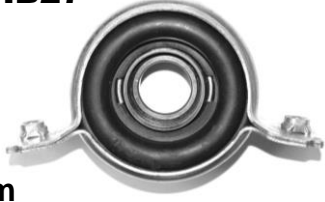
<p>BC-900</p>  <p>30mm</p> <p>Avanza (06-16)</p>	<p>BC-0K020</p>  <p>30mm</p> <p>Hilux 4WD (04-15)</p>	<p>BC-1600-10</p>  <p>30mm</p> <p>Toyota RAV4 (96-00)</p>
--	--	---

5.1 Soportes para barra de cardán Drive shaft support



Toyota

<p>BC-1820-10</p>  <p>30mm</p> <p>Hilux 2WD (04-en adelante)</p>	<p>BC-2380-40</p>  <p>30mm</p> <p>Tacoma 2WD (95-03) Hiace (07-14)</p>	<p>BC-36063</p>  <p>30mm</p> <p>Toyota Trucks (78-92)</p>
<p>BC-HB26</p>  <p>30mm</p> <p>Toyota T100 2WD (93-98)</p>	<p>BC-HB27</p>  <p>30mm</p> <p>Toyota 4Runner (89-95)</p>	<p>BC-HB28</p>  <p>30mm</p> <p>Toyota T100 4WD (94-98)</p>
<p>BC-HB31</p>  <p>30mm</p> <p>Toyota Tacoma 4WD (95-03)</p>	<p>BC-TRN25R</p>  <p>30mm</p> <p>Toyota Pick Up RN25 (79-80)</p>	<p>BC-HB7</p>  <p>30mm</p> <p>Celica (82-85), Supra (85-88), Tercel (83-88)</p>
<p>BC-HB8</p>  <p>30mm</p> <p>Toyota Pick ups 2WD (84-90)</p>	<p>BC-HB9</p>  <p>30mm</p> <p>Toyota Pick ups (91-95)</p>	<p>BC-T2WAR</p>  <p>30mm</p> <p>Toyota Pick Ups 4X2 (79-93)</p>

5.1 Soportes para barra de cardán Drive shaft support



Toyota

BC-T4WAR



30mm

Toyota Pick Up 4X4 (79-93)

BC-TRN20R



30mm

Toyota Pick Ups RN20 (73-75)

6.1 Tablas de equivalencias

Filtro y empaque de transmisión automática



FR #	LODI #
FT-1013A	FC-TH400A
FT-1015	FC-TF6CH
FT-1017	FC-PWRGLIDE
FT-1019A	FC-TH425
FT-1020	FC-TH400
FT-1020A	FC-TH400L
FT-1021	FC-TH350NY
FT-1024	FC-FMX
FT-1025	FC-C6A
FT-1027	FC-C4A
FT-1028	FC-C4
FT-1033A	FC-TH350C
FT-1034	FC-AT540
FT-1035	FC-C4N
FT-1036	FC-TH200L
FT-1037	FC-C6N
FT-1038	FC-C3
FT-1039	FC-TF6/8
FT-1039	FC-TF8
FT-1040	FC-BWT35
FT-1042A	FC-FMXF
FT-1043	FC-A404F
FT-1044	FC-3N71A
FT-1045	FC-A41
FT-1046	FC-3N71A
FT-1047	FC-TH125
FT-1048	FC-TH200NY
FT-1050	FC-TH180
FT-1051A	FC-MT640
FT-1053	FC-TF6G
FT-1054A	FC-C4D
FT-1055	FC-C6
FT-1056	FC-FIOD
FT-1057B	FC-TH200R4
FT-1057C	FC-TH700A
FT-1058	FC-ATX
FT-1059	FC-C5
FT-1060	FC-M41
FT-1060	FC-M41A
FT-1061	FC-VW010
FT-1062A	FC-TH325N
FT-1063	FC-TH325
FT-1064	FC-C54
FT-1065	FC-A404M
FT-1066	FC-A40D
FT-1068	FC-F3AE
FT-1068	FC-F3AM
FT-1069	FC-TSURU
FT-1070	FC-KM171
FT-1070	FC-KM170
FT-1071	FC-A55F
FT-1072	FC-TH440N
FT-1073	FC-AXOD
FT-1073A	FC-AX4S
FT-1073B	FC-AX4S
FT-1074	FC-TH700N
FT-1076	FC-ZF4HP22
FT-1077	FC-A240E
FT-1083	FC-A340E
FT-1084	FC-MX1
FT-1086	FC-FIOD4
FT-1087	FC-A4LDE4
FT-1088	FC-A4LDA

FR #	LODI #
FT-1092	FC-JATCO
FT-1094	FC-R4AXELA
FT-1099	FC-A43D
FT-1100	FC-ZF3HP22
FT-1102	FC-AW4
FT-1103	FC-L4N71B
FT-1104	FC-4EATG
FT-1105	FC-A340H
FT-1106	FC-KM177
FT-1110	FC-MX17
FT-1111	FC-JF403E
FT-1112	FC-A42DL
FT-1113	FC-RL3F01A
FT-1115	FC-A4LDE
FT-1115A	FC-A4LDE
FT-1119	FC-F3A
FT-1121	FC-A43DE
FT-1122	FC-A604
FT-1123	FC-4EAT
FT-1124	FC-RE4R03A
FT-1128	FC-A55F4
FT-1129	FC-TH700E6
FT-1130	FC-E4OD4W
FT-1131	FC-C6E
FT-1132	FC-A440FD
FT-1133	FC-KM175
FT-1134	FC-4L80E
FT-1137	FC-A141L
FT-1138	FC-R4AEL
FT-1139	FC-E4N71B
FT-1140	FC-G4AHL
FT-1141	FC-A606
FT-1142	FC-A540E
FT-1143	FC-4EATGN
FT-1144	FC-FIODE
FT-1145	FC-4R01A4W
FT-1146	FC-TH700E
FT-1149	FC-4L30E6
FT-1150	FC-R4AXELN
FT-1151	FC-4F04A
FT-1152	FC-F3AF
FT-1153	FC-F4A33
FT-1154	FC-KM176A
FT-1154	FC-KM176N
FT-1158	FC-SENTRA
FT-1159	FC-JF403N
FT-1161	FC-F3AATX
FT-1162	FC-A245E
FT-1164	FC-AX4N
FT-1166	FC-4T40E
FT-1167	FC-FIOD4E
FT-1169	FC-A141E
FT-1170	FC-4L30E
FT-1172	FC-4T80E2
FT-1181	FC-U140E
FT-1185	FC-A340
FT-1186	FC-VWAG4
FT-1187	FC-5HP19
FT-1191	FC-A341E
FT-1193	FC-A4AF1
FT-1193	FC-F4A21
FT-1194	FC-4R01A2W
FT-1194	FC-4R01AP

FR #	LODI #
FT-1196	FC-A541E
FT-1197	FC-A340F
FT-1201	FC-4L60E
FT-1203	FC-4L80ER2
FT-1206	FC-44RE
FT-1210	FC-4F27E
FT-1211	FC-MPWA
FT-1214	FC-W5A580
FT-1215	FC-4F04A
FT-1216	FC-A340F4
FT-1217	FC-4L60EB
FT-1218	FC-MPYA
FT-1219	FC-M4VA
FT-1220	FC-U341E
FT-1222	FC-45RFE
FT-1223	FC-45RFE4
FT-1224	FC-5R55W
FT-1225	FC-A4AF
FT-1226	FC-5R110W
FT-1227	FC-5R110WCA
FT-1228	FC-L1000
FT-1229	FC-L1000A
FT-1230	FC-4L60EA
FT-1232	FC-U151E
FT-1233	FC-42RLEA
FT-1235	FC-A246E
FT-1236	FC-6R60
FT-1238	FC-6L90
FT-1239	FC-5R110WN
FT-1240	FC-62TE
N / D	FC-6T70
N / D	FC-A46DE
N / D	FC-AW450
N / D	FC-AXODA
N / D	FC-B7XA
N / D	FC-BAXA
N / D	FC-BDGA
N / D	FC-BVLA
N / D	FC-C6EP
N / D	FC-CFT30
N / D	FC-DPO
N / D	FC-F4A41A
N / D	FC-FNR5
N / D	FC-JF506E
N / D	FC-MPJACA
N / D	FC-RE4F04B
N / D	FC-RE5R05A
N / D	FC-SLYA
N / D	FC-SPCA
N / D	FC-TF81SC
N / D	FC-VW09D
P6646	FC-TAATCA
P9264	FC-L1000CA
PH9688	FC-F4A411CA

6.1 Tablas de equivalencias

Filtro y empaque de transmisión automática



CHR #	LODI #
JT-201	FC-A404F
JT-202	FC-A604
JT-203	FC-A404M
JT-206	FC-TF8
JT-206A	FC-TF6G
JT-207	FC-TF6CH
JT-207A	FC-TF8CH
JT-208	FC-TF6/8
JT-209	FC-A606
JT-210	FC-44RE
JT-211	FC-45RFE
JT-211A	FC-45RFE4
JT-211SO	FC-45RFECA
JT-212	FC-AW4
JT-213	FC-A4AF
JT-214	FC-42RLEA
JT-215	FC-42RLE
JT-216	FC-JF011E
JT-216SF	FC-CVTC
JT-217	FC-62TE
JT-218	FC-A465
JT-219	FC-6F24
JT-220	FC-AS69RC
JT-221	FC-948TE
JT-301	FC-A4LDR
JT-301A	FC-A4LDA
JT-301B	FC-A4LD
JT-302	FC-FIOD
JT-302A	FC-FIOD4
JT-303	FC-AXODA
JT-303A	FC-AX4S
JT-303A	FC-AXOD
JT-303B	FC-AX4N
JT-304	FC-ATX
JT-305	FC-C3
JT-306	FC-C4N
JT-307	FC-C4
JT-308	FC-C5
JT-309	FC-C6A
JT-310	FC-C6N
JT-311	FC-FMX
JT-311A	FC-FMXF
JT-312	FC-FIODE
JT-312A	FC-FIOD4E
JT-313	FC-4EAT
JT-313A	FC-F4AEL
JT-314	FC-E40D4WP
JT-314A	FC-C6EP
JT-314AF	FC-C6E
JT-314F	FC-E40D4W
JT-315	FC-CD4E
JT-316	FC-A4LDE
JT-316A	FC-A4LDE4
JT-317	FC-4F27E
JT-317A	FC-FNR5
JT-318	FC-C54
JT-319	FC-5R55N
JT-320	FC-5R55W
JT-321	FC-4EATG
JT-322	FC-4EATGN
JT-323	FC-F3A
JT-324	FC-C6
JT-325	FC-C4D

CHR #	LODI #
JT-326	FC-C4A
JT-327	FC-F3AF
JT-328	FC-F3AATX
JT-329	FC-5R55S
JT-330	FC-5R110W
JT-330C	FC-5R110WCA
JT-331	FC-6R60
JT-332	FC-JF506E
JT-333	FC-CFT30
JT-334	FC-6R75
JT-335	FC-CFT23
JT-336	FC-TF81SC
JT-337	FC-5R110WN
JT-340	FC-6F35
JT-341	FC-6R80
JT-342	FC-6R140
JT-343	FC-318
JT-345	FC-6F35L
JT-346	FC-319
JT-347	FC-6F35N
JT-401	FC-TH125
JT-401A	FC-TH125
JT-402	FC-TH180
JT-403	FC-TH200L
JT-404	FC-TH200R4
JT-405	FC-TH200NY
JT-406	FC-TH350NY
JT-407	FC-TH350L
JT-408	FC-TH400
JT-408A	FC-TH400L
JT-409	FC-TH440N
JT-409A	FC-TH440N
JT-410	FC-TH700N
JT-411	FC-TH700A
JT-412	FC-TH700E6
JT-413	FC-TH700E
JT-413A	FC-TH700E8N
JT-413B	FC-4L60E
JT-414	FC-4T40E
JT-415	FC-4T80E
JT-415AB	FC-4T80E2
JT-416	FC-4L80E
JT-416A	FC-4L80ER2
JT-417	FC-PWRGLIDE
JT-418	FC-4L30E
JT-419	FC-4W60
JT-420	FC-4L30E6
JT-421	FC-A43DE
JT-422	FC-TH350C
JT-423	FC-TAAT
JT-423SO	FC-TAATCA
JT-424	FC-TH325
JT-424A	FC-TH325N
JT-425	FC-MX17
JT-426	FC-MX1
JT-427	FC-4L60EB
JT-427H	FC-4L60EH
JT-428	FC-4L60EA
JT-429	FC-6L80
JT-430	FC-TH700EP
JT-431	FC-TH400A
JT-432	FC-TH425
JT-433	FC-JF403E

CHR #	LODI #
JT-435	FC-6T70
JT-437	FC-AW50
JT-438	FC-AW81
JT-439	FC-6L90
JT-440	FC-TH700E6
JT-441	FC-AW55
JT-442	FC-4T45E
JT-444	FC-6T40E
JT-446	FC-6L80E
JT-447	FC-VT25E
JT-449	FC-320
JT-451	FC-321
JT-455	FC-8L45
JT-456	FC-322
JT-457	FC-8L90
JT-501	FC-3N71A
JT-502	FC-JATCO
JT-503	FC-TSURU
JT-503A	FC-RL3F01A
JT-503B	FC-RN3F01A
JT-504	FC-SENTRA
JT-505	FC-4F02A
JT-506	FC-4R01A4W
JT-506A	FC-4R01AP
JT-506B	FC-4R01A2W
JT-507	FC-4F04A
JT-508	FC-4F04AN
JT-509	FC-4F04AN
JT-510	FC-RE5R05A
JT-511	FC-RE4R03A
JT-512	FC-JR503E
JT-513	FC-AW55
JT-514	FC-RE4F04B
JT-515	FC-JF010E
JT-515A	FC-323
JT-516	FC-RE4F03V
JT-517	FC-RE0F10A
JT-518	FC-RE7R01A
JT-519	FC-324
JT-520	FC-325
JT-521	FC-326
JT-522	FC-327
JT-523	FC-328
JT-524	FC-JF017E
JT-601	FC-VW010
JT-601A	FC-VW010A
JT-602	FC-VW095
JT-603	FC-VWAG4
JT-604	FC-VW098
JT-605	FC-5HP19
JT-606	FC-VW010E
JT-607	FC-329
JT-608	FC-330
JT-609	FC-VW09D
JT-610	FC-VW003
JT-612	FC-VW01J
JT-617	FC-4HP18FLA
JT-619	FC-VW09E
JT-620	FC-VW02E
JT-621	FC-VW02EN
JT-622	FC-ZF6HP19A
JT-623	FC-VW09G
JT-624	FC-ZF8HP45

6.1 Tablas de equivalencias

Filtro y empaque de transmisión automática



CHR #	LODI #
JT-625	FC-VW09M
JT-627	FC-331
JT-628	FC-332
JT-629	FC-333
JT-632	FC-334
JT-636	FC-335
JT-641	FC-336
JT-642	FC-337
JT-643	FC-338
JT-644	FC-VW09GN
JT-645	FC-339
JT-646	FC-333
JT-649	FC-AL450
JT-7000	FC-A343F
JT-7001	FC-A340F
JT-7002	FC-A340F4
JT-7003	FC-A340
JT-7004	FC-A540E
JT-7005	FC-A141E
JT-7006	FC-A541E
JT-7007	FC-A340H
JT-7008	FC-A43D
JT-7009	FC-A55F
JT-701	FC-MT640
JT-7010	FC-A55F4
JT-7011	FC-U341E
JT-7012	FC-A340E
JT-7013	FC-A245E
JT-7014	FC-A41
JT-7015	FC-A141L
JT-7016	FC-A240E
JT-7017	FC-A40D
JT-7018	FC-A42DL
JT-7019	FC-U140E
JT-7020	FC-A350E
JT-7021	FC-A240E
JT-7022	FC-A46DE
JT-7025	FC-A440FD
JT-7026	FC-A440F
JT-7027	FC-A341E
JT-7028	FC-A30
JT-7029	FC-A750E
JT-702F	FC-AT540
JT-703	FC-L1000
JT-7030	FC-A750F
JT-7032	FC-U660E
JT-7033	FC-U151E
JT-7035	FC-U540E
JT-7036	FC-A246E
JT-7037	FC-A4LB1
JT-7039	FC-A650E
JT-703A	FC-L1000A
JT-703SO	FC-L1000CA
JT-7041	FC-340
JT-7047	FC-341
JT-7050	FC-342
JT-7053	FC-343
JT-7054	FC-359
JT-7055	FC-AC60F
JT-7055	FC-344
JT-7057	FC-345
JT-708	FC-HT700
JT-709	FC-HT740

CHR #	LODI #
JT-710	FC-HT750
JT-7100	FC-B7XA
JT-7101	FC-BAXA
JT-7101SO	FC-MPJACA
JT-7102	FC-MPXA
JT-7103	FC-M4TA
JT-7104	FC-MDLA
JT-7105	FC-A24A
JT-7106	FC-M4VA
JT-7107	FC-HONDA3
JT-7109	FC-M4VAP
JT-7110	FC-CVTH
JT-7111	FC-346
JT-7112	FC-BDKA
JT-7113	FC-BVLA
JT-7114C	FC-BDGA
JT-7115	FC-G4
JT-7116	FC-MPWA
JT-7117	FC-HONDAMATIC
JT-7120	FC-MPYA
JT-7121	FC-347
JT-7123	FC-MPRA
JT-7124	FC-APX4
JT-7125	FC-348
JT-7127	FC-SLYA
JT-7128	FC-SZCA
JT-7129	FC-M7WA
JT-7130	FC-SMMA
JT-7130SF	FC-SMMACA
JT-7131	FC-M91A
JT-7132	FC-B97A
JT-7133	FC-MURA
JT-7134	FC-SPCA
JT-7135	FC-PN3A
JT-7138	FC-ML4A
JT-7139	FC-K4
JT-7143	FC-MV2A
JT-7145	FC-349
JT-7146	FC-350
JT-7200	FC-E4N71B
JT-7201	FC-F3AM
JT-7202	FC-F3AG
JT-7203	FC-4R01A4W
JT-7204	FC-GF4AEL
JT-7205	FC-3N71A
JT-7206	FC-L4N71B
JT-7207	FC-G4AHL
JT-7208	FC-JF403N
JT-7209	FC-4EATGN
JT-7211	FC-R4AEL
JT-7213	FC-FW6AEL
JT-7300	FC-F4A51D
JT-7301	FC-F1C1
JT-7302	FC-F4A51T
JT-7303	FC-V4A51
JT-7304	FC-KM171
JT-7304A	FC-KM170
JT-7305	FC-KM175
JT-7306	FC-KM177
JT-7307	FC-F4A33
JT-7308	FC-KM176A
JT-7308	FC-KM176N
JT-7309	FC-A4AF1

CHR #	LODI #
JT-7310	FC-F4A21
JT-7311	FC-R4A51
JT-7312SO	FC-F4A411CA
JT-7313	FC-F4A41A
JT-7314	FC-F4A51A
JT-7323	FC-351
JT-7500	FC-4L30E
JT-7502	FC-AW450
JT-7604	FC-352
JT-7900	FC-4EATS
JT-7900SO	FC-4EATCA
JT-7901	FC-R4AXELN
JT-7902	FC-R4AXELA
JT-7907	FC-ECVT
JT-7909	FC-353
JT-7910	FC-354
JT-8000	FC-W5A580
JT-8001	FC-722
JT-8002A	FC-W4A040
JT-8003	FC-W4A020
JT-8004	FC-W5A030
JT-8005	FC-722.9
JT-8007	FC-W3A040
JT-8008	FC-W4B025
JT-8009	FC-W3A040N
JT-8100	FC-4L30E6
JT-8101	FC-5L40E
JT-8102	FC-5L40EA
JT-8103	FC-5L40EB
JT-8104	FC-ZF4HP22
JT-8106	FC-ZF5HP18
JT-8107	FC-ZF5HP30
JT-8109	FC-ZF6HP26
JT-8110	FC-ZF6HP19
JT-8112	FC-358
JT-8113	FC-6L45R
JT-8114	FC-ZF3HP22
JT-8115	FC-ZF4HP14
JT-8116	FC-355
JT-8117	FC-356
JT-8118A	FC-357
JT-8550	FC-ZF4HP18
JT-8700	FC-DPO
JT-8800	FC-DPO
JT-8801	FC-MJ3
JT-8901	FC-4HP22R
N / D	FC-A727
N / D	FC-A904
N / D	FC-BWT35
N / D	FC-BWT65
N / D	FC-BWT66
N / D	FC-F38CA
N / D	FC-F516CA
N / D	FC-M101
N / D	FC-M41
N / D	FC-M41A
N / D	FC-360
N / D	FC-361
N / D	FC-362
N / D	FC-363

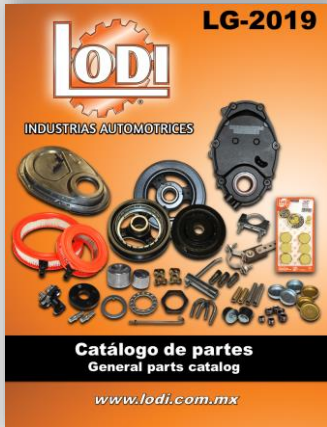

**PARTES GENERALES
MOTOR Y MISCELANEO**



**PARTES DE
TRANSMISIÓN**

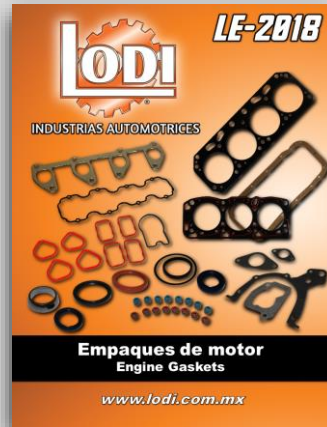

**EMPAQUES
DE MOTOR**



**PARTES PARA
FRENOS**



**CABLES PARA
BUJIAS**



**BOBINAS DE
IGNICIÓN**



**BOMBAS DE
GASOLINA**



**VALVULAS
VVT**

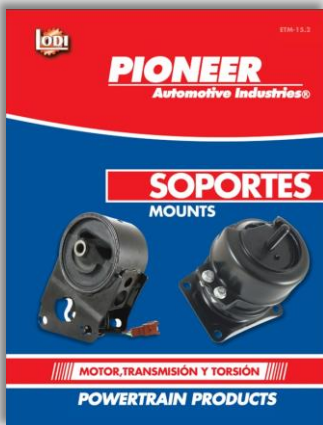

**SOPORTES PARA
MOTOR, TRANSMISIÓN
Y TORSIÓN**



**ELEVADORES
DE VENTANA**

**Chatea con nosotros
en línea en: www.lodi.com.mx**



LODI Industrias Automotrices



INDUSTRIAS AUTOMOTRICES

Distribuido por:



Soporte técnico: 01800-227-5634

CAS LODI

info@lodi.com.mx



LODI Industrias Automotrices



@IALodi



811 022 4604